



FEATURES

- Loop-powered, no external supply required
- Includes gain (span) and offset (zero) adjustments
- Range and decimal point settings are DIP-switch selectable
- Covers hundreds of different ranges
- Reliable screw-terminal connections
- Low cost

PRODUCT OVERVIEW

Description: The DMS-EB-LP was specifically designed for 4-to-20mA current-loop process-monitoring applications. The board simply mounts onto the rear of a DMS- 30LCD-1-5, allowing both the application board and the meter to be powered solely from the 4-to-20mA loop input. Align pin 1 of the board with pin 1 of the DMS-30LCD-1-5 and simply solder the two assemblies together.

Features: Gain (span) and offset (zero) adjustments are both performed using precision, 22-turn potentiometers. Decimal point selections and range changes are all made on an eight-position DIP switch featuring gold-plated contacts — there are no cumbersome jumpers or solder gaps to contend with! Connections to the loop are made via a reliable, screw-type terminal block. The only assembly tool required is a screwdriver!

Applications: The DMS-EB-LP's design accommodates hundreds of different display reading combinations. This essentially eliminates the need to order "specials" in applications in which several different range meters are required. OEM customers should consider using DATEL's DMS-30LCD-4/20S which already has the DMS-EB-LP soldered to a rugged DMS-30LCD-1-5 digital voltmeter.

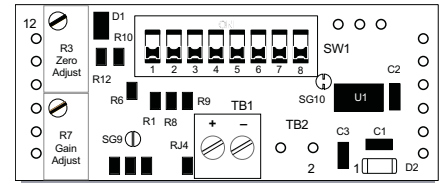

SIMPLIFIED SCHEMATIC

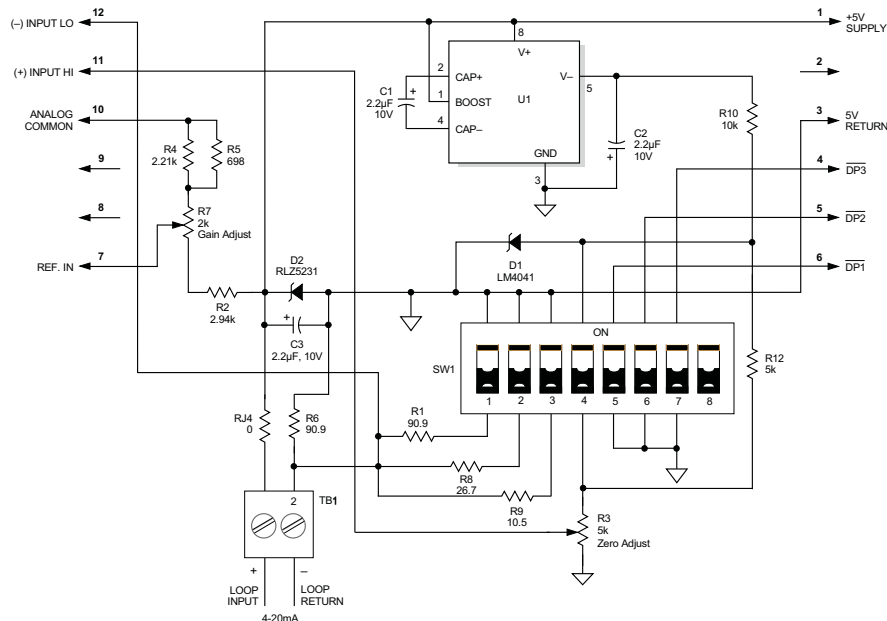

Figure 1. DMS-EB-LP Schematic Diagram



Performance/Functional Specifications

(TA = +25°C)

Input	
Full Scale Input	4mA to 20mA
Performance	
Voltage Drop	7.5V, maximum
Input Resistance	550Ω, nominal
Accuracy	±0.05%FS ±1 count
Operating Temperature Range	0 to +60°C
Temperature Drift	±100ppm/°C, typical
Physical/Environmental	
Storage Temperature	-20 to +75°C
Humidity	0 to 95%, non-condensing
Dimensions	2.02" (51.31mm)L x 0.83" (21.08mm)W
TB1 Wire Size and Strip Length:	18 to 26 AWG (solid or stranded) Strip Length 0.20" (5.08mm)

Ordering Information

Model

DMS-EB-LP	Current loop board
DMS-BZL1	Bezel assembly
DMS-BZL2	Bezel assembly with sealing gasket

Operating and Setup Instructions

As shipped, the DMS-EB-LP is factory calibrated to read "000" for a 4mA input and "1999" for a 20mA input but may require recalibration when connected to a DMS-30LCD-1-5 digital voltmeter.

The following worst-case procedure assumes the DMS-EB-LP is completely mis-adjusted, i.e., both potentiometers and the DIP switches are randomly set.

- Set R7 (full scale gain adjust) and R3 (zero/offset adjust) fully clockwise, roughly 22 turns, and place SW1-SW8 to OFF (down position).
- Set SW1 to ON (up position). See DIP switch setting #3 in Table 1.
- Apply a precision 4mA input, with proper polarity, and adjust R3 until the meter's display reads "000".
- Apply a precision 20mA input and adjust R7 until the meter's display reads "1999". Repeat steps 3 and 4 to make sure the adjustments do not affect one another.
- Select the appropriate decimal point by setting SW5, SW6 or SW7 to ON (DP1, DP2 or DP3 respectively).

NOTE: If a display reading other than "000" to "1999" is desired, refer to Table 1 for SW1-SW4 settings.

Display Reading	SW1	SW2	SW3	SW4
1. 000 to 100-300	On	On	On	Off
2. 000 to 400-600	Off	On	Off	Off
3. 000 to 700-1999	On	Off	Off	Off
4. ±100	On	On	On	Off
5. ±200 to ±300	On	On	Off	Off
6 ±400 to ±600	On	Off	Off	Off
7 ±700 to ±1900	Off	Off	Off	On

Table 1. DIP-Switch Settings

NOTE: When looking up DIP-switch settings in the Table and the desired display readings happen to fall between two switch settings, try performing the adjustments with both settings to determine which one offers the better settability. Please keep in mind that the DMS-30LCD meter has an accuracy specification of ±2 counts (max.). Thus, it may not always be possible to obtain the exact desired display reading.

Examples

- Desired display readings are:
 - 4mA = "0.00"
 - 20mA = "2.00"

Use DIP-switch setting #1 and enable decimal point DP2 via SW6. Apply 4mA and adjust R3 so the display reads "0.00". Apply 20mA and adjust R7 so the display reads "2.00".
- Desired display readings are:
 - 4mA = "-100"
 - 12mA = "000"
 - 20mA = "100"

Use DIP-switch setting #4. Apply 12mA and adjust R3 so the display reads "000". Apply 20mA and adjust R7 so the display reads "100". Apply 4mA and the display should read "-100". For these display readings, no decimal points are used. Set SW5, SW6 and SW7 to OFF (down position).
- Desired display readings are:
 - 4mA = "-157.5"
 - 12mA = "00.0"
 - 20mA = "157.5"

Use DIP-switch setting #7 and enable decimal point DP3 via SW7. Apply 12mA and adjust R3 so the display reads "000". Apply 20mA and adjust R7 so the display reads "157.5". Apply 4mA and the display should read "-157.5".
- Desired display readings are:
 - 4mA = ".000"
 - 12mA = ".250"

This example is not as straightforward as the previous three. Notice that 12mA is exactly halfway between 4mA and 20mA. If we assume that the input could go up to 20mA, the display reading would then be: 2 x .250 or ".500". From the chart, we can now select DIP-switch setting #2 and enable DP1 via SW5. Apply 4mA and adjust R3 so the display reads ".000". Apply 12mA and adjust R7 so the display reads ".250".

