

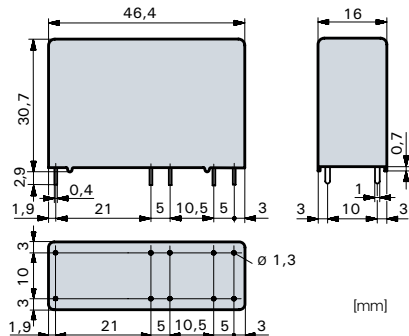

Relay data

- PCB relay with forcibly guided contacts
- Protective separation between coil/control contacts and output contacts (> 10mm) as well as protective separation between the output contacts themselves (> 8mm)
- EN 50205, type A
- Contact mounting:
SIR312 3NO/1NC
SIR222 2NO/2NC
- Small external dimensions
- Mean coil power 0,6W



Contact material	AgSnO ₂ +0,2μm Au
Type of contact	Crest contact
Rated switching capacity	250VAC 10A AC1 2'500VA
Electr. life AC1 (360 cycles/h)	approx.100'000
Inrush current max.	25A for 20ms
Switching current range*	10mA to 10A
Switching capacity range*	0,06VA(W) to 2'500VA
Contact resistance (as delivered)	≤ 100mΩ

* Guide values

Standard coils for direct current (other voltages on request)

Nominal voltage VDC	Min. pick-up voltage at 20°C	Drop-out voltage at 20 °C	Nominal current in mA	Resistance in Ohm at 20 °C	Tolerance in %
5	3,5	≥ 0,5	121,0	41	± 10
6	4,2	≥ 0,6	100,0	60	± 10
12	8,4	≥ 1,2	50,0	240	± 10
24	16,8	≥ 2,4	25,2	950	± 10
48	33,6	≥ 4,8	12,6	3'800	± 10
60	42,0	≥ 6,0	10,0	6'000	± 13
110	77,0	≥ 11,0	5,5	20'000	± 15

Ordering example

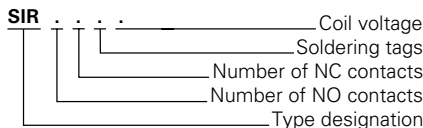

General data

Circuit diagram (view on relay upper side)

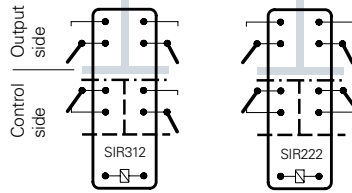

- - - - - Basic insulation
- ▬ Double or reinforced insulation
- · - · - · EEx insulation

Mechanical life	> 10 x 10 ⁶ operations
Switching frequency, mechanical	15Hz
Response time	typically 15ms
Drop-out time**	typically 4ms
Bounce time of NO contact	typically 6ms
Bounce time of NC contact	typically 12ms
Shock resistance	16ms NO contact > 10g NC contact 6g

Vibration resistance	NO contact > 5g 10-200Hz NC contact 1,5g
Test voltage coil/control contacts	2'500Veff 1min
Test voltage coil-control contacts/output contacts	5'000Veff 1min
Test voltage output contacts as against each other	4'000Veff 1min
Test voltage contact open	1'500Veff 1min
Insulation resistance	10 ¹¹ Ω
Creeping resistance	CTI 250
Weight	approx. 30g
Mounting position	any
Ambient temperature	-40°C to +70°C
Type of protection	RT II
Solder bath temperature	270 °C/5s
Thermal resistance	55K/W
Temperature limit for coil	120°C
Pollution degree	3
Overvoltage category	III
Resistance to short circuiting	1'000A SCPD 10A gG (pre-fuse)

** without spark suppression

Insulation terms

Coil to control contacts:	Basic insulation
Coil/control contacts to output contacts:	Double or reinforced insulation
EEx insulation	> 10mm
Output contacts as against each other:	Double or reinforced insulation > 8mm

Tests, regulations

Approvals	SEV, UL, cUL, TÜV
Insulation class	VDE 0110 / group C 250VAC
Protection class II	VDE 0106
Fire protection requirements	UL 94 / V0

Options, accessories

PCB socket	see page 25
------------	-------------

Diagrammes

Contact lifetime

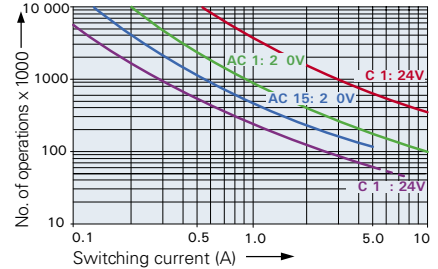

Max. switching characteristics (determined acc. to DIN EN 60947-5-1 table C2):
 AC 15: 230V/5A
 DC 13: 24V/7,5A/0,1 Hz

Maximal contact load at AC 1 with 230V:
 2 contacts each with 10A
 3 contacts each with 8,4A

Load limit curve with direct current

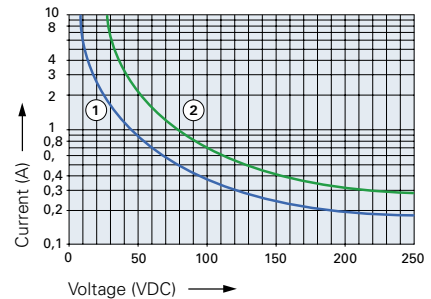

- 1) Inductive load, L/R 40 ms
- 2) Resistive load

Excitation voltage range

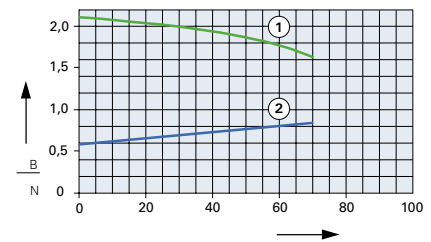

- 1) Max. excitation voltage with contact load ≤ 2A
- 2) Min. excitation voltage (guaranteed values) without previous operation

No heat accumulation due to intrinsic heating of other components.
 Continuous duty 100%.