

SERIES RSE H2

● FEATURES

- SUITABLE FOR TIME OF DAY CLOCK APPLICATIONS
- LOW PROFILE 2 mm HEIGHT
- EXCELLENT FOR AUTOMATIC AND HIGH DENSITY SURFACE MOUNTING

● SPECIFICATIONS

NOMINAL FREQUENCY	32.768 kHz
FREQUENCY TOLERANCE	±20 PPM MAXIMUM (±50 PPM AND ±100 PPM AVAILABLE)
TURNOVER TEMPERATURE	±25°C ±5 °C
TEMPERATURE COEFFICIENT	(-0.035± 0.008) PPM/Δ°C ²
LOAD CAPACITANCE	12.5 pF
EQUIVALENT SERIES RESISTANCE	55 KOHMS MAXIMUM
DRIVER LEVEL	1.0 μW MAXIMUM
SHUNT CAPACITANCE	1.5 pF MAXIMUM
AGING (FIRST YEAR)	±5 PPM MAXIMUM
OPERATING TEMPERATURE RANGE	-40°C TO +85°C
STORAGE TEMPERATURE RANGE	-55°C TO +125°C
SHOCK RESISTANCE	±5 PPM MAXIMUM 75 cm DROP TEST IN 3 AXES ONTO A HARD SURFACE OR 3000 g x 0.3 ms x ½ SINEWAVE IN 3 AXES
SOLDER REFLOW CONDITIONS	230°C MAXIMUM FOR 20s MAXIMUM



● OUTLINE DRAWING

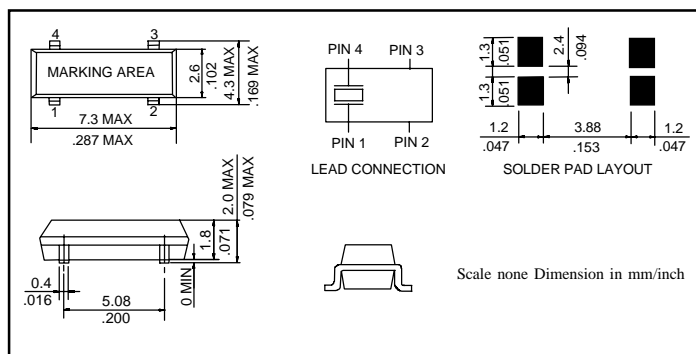

● REFLOW SOLDERING PROFILE

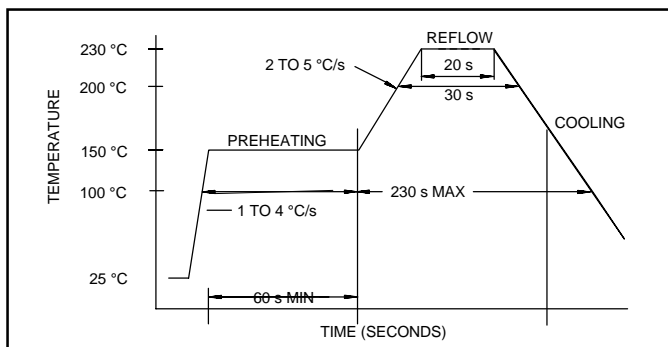

● CARRIER TAPE DIMENSIONS

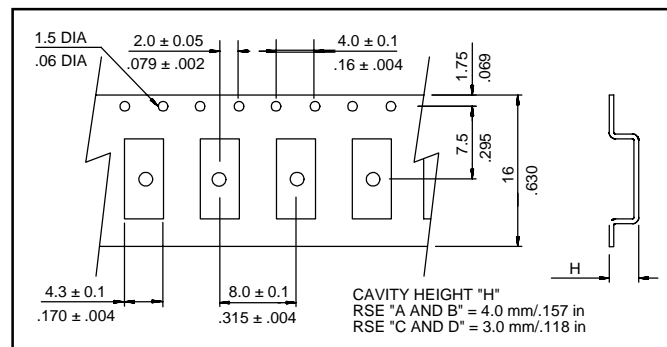

● FREQUENCY VS. TEMPERATURE CURVE

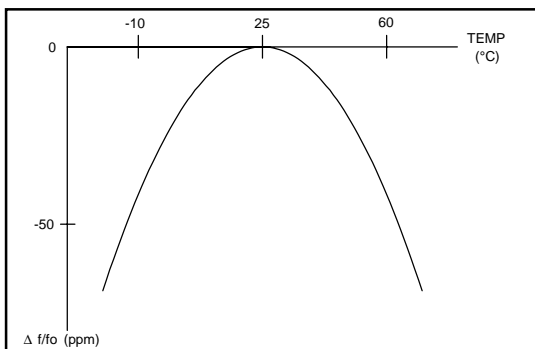

● PACKAGING

330mm REEL DIAMETER
16mm TAPE WIDTH, 8mm PITCH
QUANTITY: 3000 PIECES PER REEL

● PART NUMBERING SYSTEM

HOLDER TYPE	FREQUENCY	LOAD CAPACITANCE	H2	TAPE AND REEL
RSE	IN kHz	12.5 pF		TR

EXAMPLE: RSE-32.768-12.5-H2-TR