

- Microminiature, polarized, bistable relays with one coil
- **DC coils of up to 24 V DC**, low coil power 0,10...0,15 W
- Terminals 2,54 mm - DIL Pitch Terminals
- Dielectric strength 1000 Vrms, sealed, for wave soldering and cleaning
- Applications: for telecommunication devices, office equipment, alarm systems, medical monitoring devices, AV devices, control sensors
- Conforms to FCC Part 68 - 1500 V - lightning surge
- Recognitions, certifications, directives: RoHS,

Contact data

Number and type of contacts		2 C/O
Contact material		AgPd/Au 0,2 μm
Rated / max. switching voltage	AC	125 V / 125 V
Min. switching voltage		10 mV
Rated load	AC1	0,5 A / 125 V AC
	DC1	1 A / 30 V DC
Min. switching current		0,01 mA
Rated current		1 A
Max. breaking capacity	AC1	62,5 VA
Contact resistance		≤ 50 mΩ

Coil data

Rated voltage	DC	3...24 V
Must release voltage	DC	-75% U _n to -U _{max} ❶
Operating range of supply voltage		see Table 1
Rated power consumption	DC	0,10...0,15 W

Insulation according to PN-EN 60664-1

Dielectric strength		
• between coil and contacts	1 000 V AC	type of insulation: basic
• contact clearance	1 000 V AC	type of clearance: micro-disconnection
Contact - coil distance		
• clearance	≥ 0,5 mm	
• creepage	≥ 0,9 mm	

General data

Operating / release time (typical values)		3 ms / 3 ms
Electrical life		
• resistive AC1	1 200 cycles/hour	10 ⁵ 0,5 A, 125 V AC
• resistive DC1	1 200 cycles/hour	2 x 10 ⁵ 1 A, 30 V DC
Mechanical life	10 800 cycles/hour	> 10 ⁸
Dimensions (L x W x H)		14,1 x 9,1 x 5 mm
Weight		1,5 g
Ambient temperature	• operating	-40...+70 °C
Cover protection category		IP 64 PN-EN 60529
Shock resistance		10 g
Vibration resistance		1,5 mm DA (constant amplitude) 10...55 Hz
Solder bath temperature		max. 235 °C
Soldering time		max. 3,5 s

The data in bold type pertain to the standard versions of the relays.

❶ Drop-out voltage are the values of the operating supply voltage range of opposite polarization, specified in Table 1.

Coil data - DC voltage version

Table 1

Coil code	Rated voltage V DC	Coil resistance ± 10% at 20°C Ω	Coil operating range at 20°C V DC		Power consumption mW
			min.	max.	
1003	3	90	2,25	4,5	100
1005	5	250	3,75	7,5	100
1006	6	360	4,50	9,0	100
1009	9	810	6,75	13,5	100
1012	12	1 440	9,00	18,0	100
1024	24	3 840	18,00	36,0	150

Dimensions

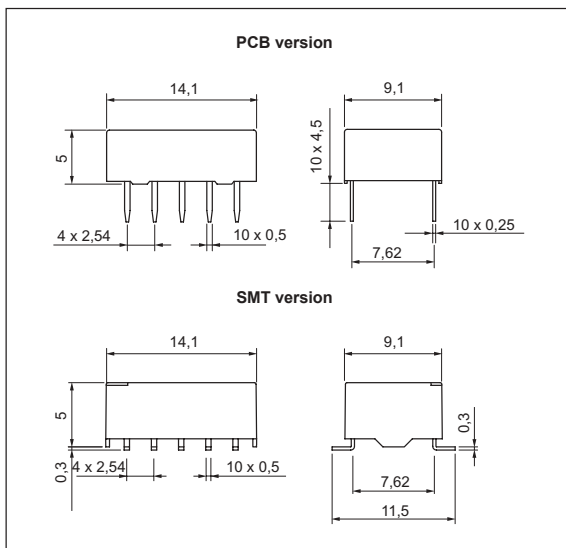

Connection diagrams (pin side view)

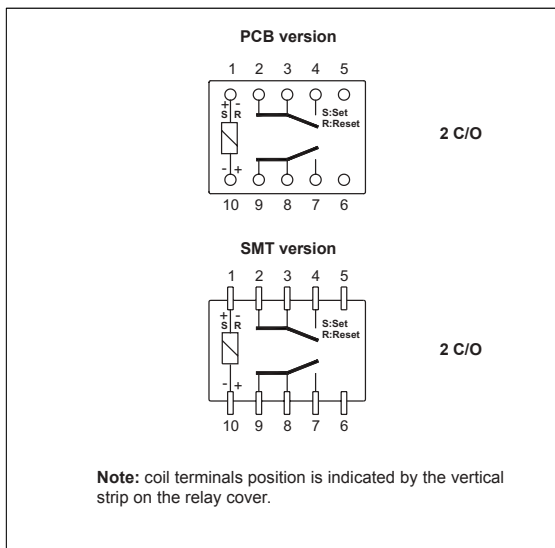

Mounting openings raster (solder side view)

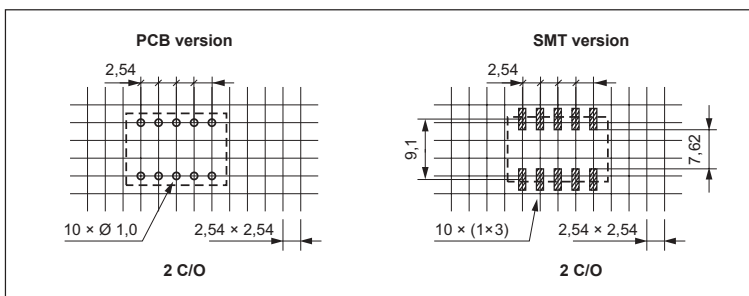

Mounting

Relays **RSM850B** are designed for:

- direct PCB mounting
- for surface mounting SMT.

Ordering codes

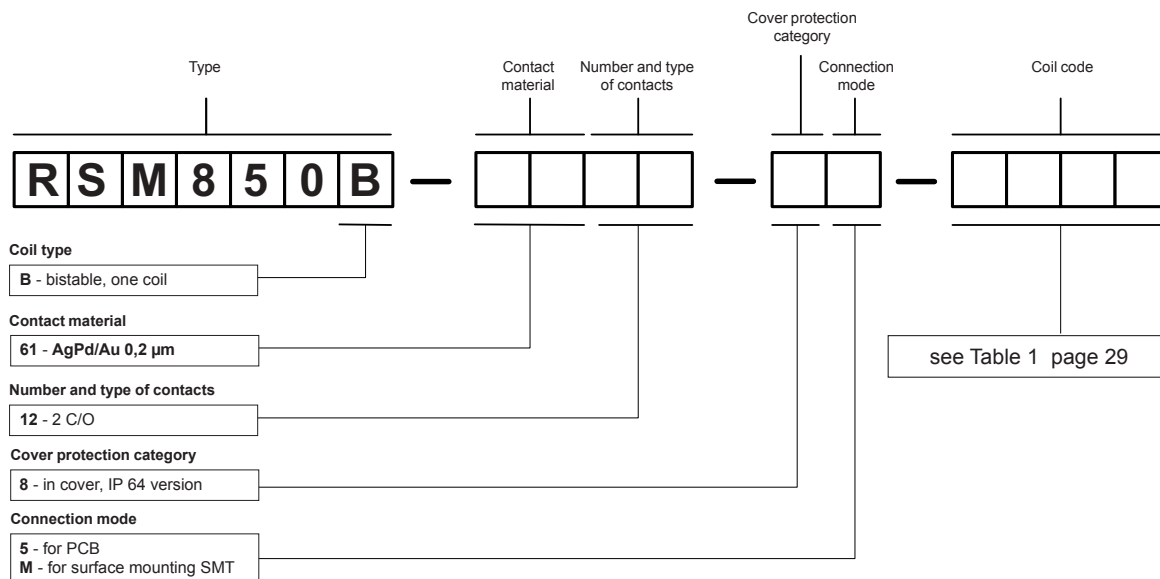

Example of ordering code:

RSM850B-6112-85-1012

bistable relay **RSM850B** with one coil, contact material AgPd/Au 0,2 µm, with two changeover contacts, in cover IP 64, for PCB, voltage version 12 V DC