



- Subminiature, monostable relays
- Small dimensions
- **DC coils of up to 24 V DC**, low coil power 0,36 W
- Sealed, for wave soldering and cleaning
- Applications: for telecommunication devices, office equipment, industrial control, etc.
- Recognitions, certifications, directives: RoHS, 

### Contact data

Number and type of contacts		1 C/O
Contact material		<b>Ag/Au 0,2 µm</b>
Rated / max. switching voltage	AC	120 V / 120 V
Min. switching voltage		5 V
Rated load	AC1	3 A / 120 V AC
	DC1	3 A / 24 V DC
Min. switching current		10 mA
Rated current		3 A
Max. breaking capacity	AC1	360 VA
Min. breaking capacity		50 mW
Contact resistance		≤ 100 mΩ

### Coil data

Rated voltage	DC	3...24 V
Must release voltage		DC: ≥ 0,05 U <sub>n</sub>
Operating range of supply voltage		see Table 1
Rated power consumption	DC	0,36 W

### Insulation according to PN-EN 60664-1

Dielectric strength		
• between coil and contacts		500 V AC type of insulation: basic
• contact clearance		500 V AC type of clearance: micro-disconnection
Contact - coil distance		
• clearance		≥ 1,2 mm
• creepage		≥ 2 mm

### General data

Operating / release time (typical values)		8 ms / 4 ms
Electrical life		
• resistive AC1	1 800 cycles/hour	10 <sup>5</sup> 3 A, 120 V AC
• resistive DC1	1 800 cycles/hour	10 <sup>5</sup> 3 A, 24 V DC
Mechanical life	18 000 cycles/hour	> 10 <sup>7</sup>
Dimensions (L x W x H)		15,4 x 10,4 x 11,4 mm
Weight		3,5 g
Ambient temperature	• operating	-25...+55 °C
Cover protection category		IP 64 PN-EN 60529
Shock resistance		10 g
Vibration resistance		1,5 mm DA (constant amplitude) 10...55 Hz
Solder bath temperature		max. 235 °C
Soldering time		max. 3,5 s

The data in bold type pertain to the standard versions of the relays.

Coil data - DC voltage version

Table 1

Coil code	Rated voltage V DC	Coil resistance ± 10% at 20°C Ω	Coil operating range at 20°C V DC		Power consumption mW
			min.	max.	
1003	3	25	2,25	3,9	360
1005	5	69	3,75	6,5	360
1006	6	100	4,50	7,8	360
1009	9	225	6,75	11,7	360
1012	12	400	9,00	15,6	360
1024	24	1 600	18,00	31,2	360

Dimensions

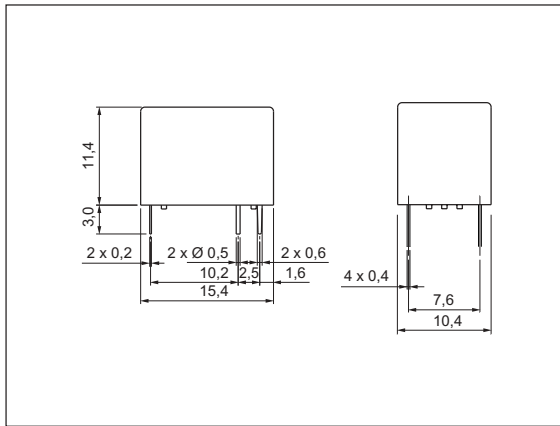

Connection diagram (pin side view)

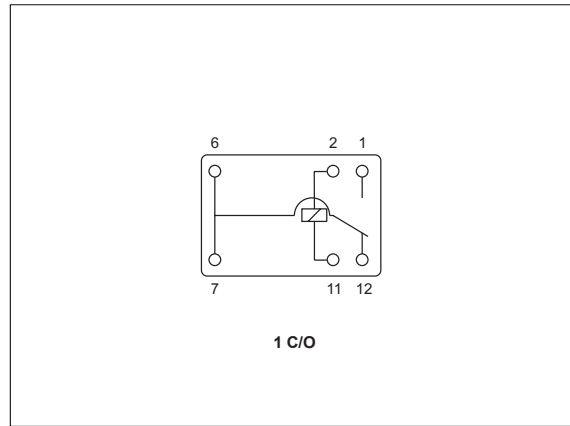

Coil temperature rise

Fig. 1

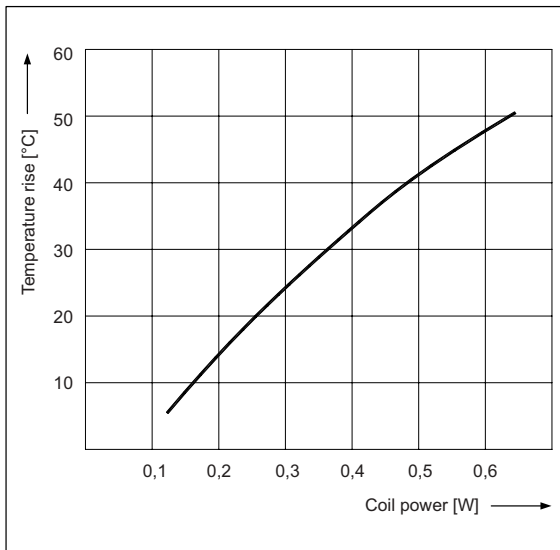

Operating / release time

Fig. 2

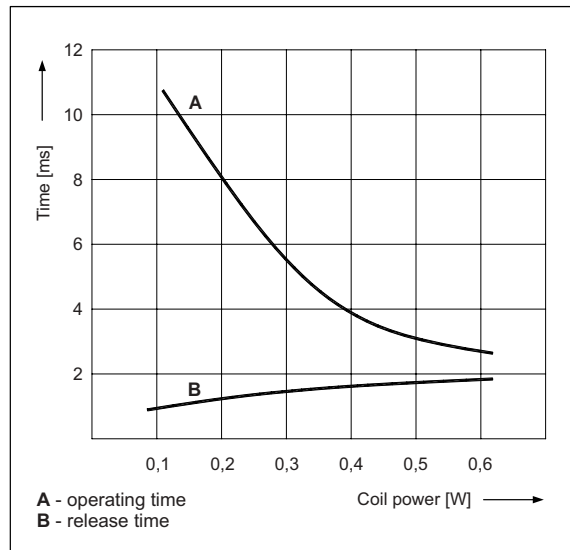

### Electrical life

Fig. 3

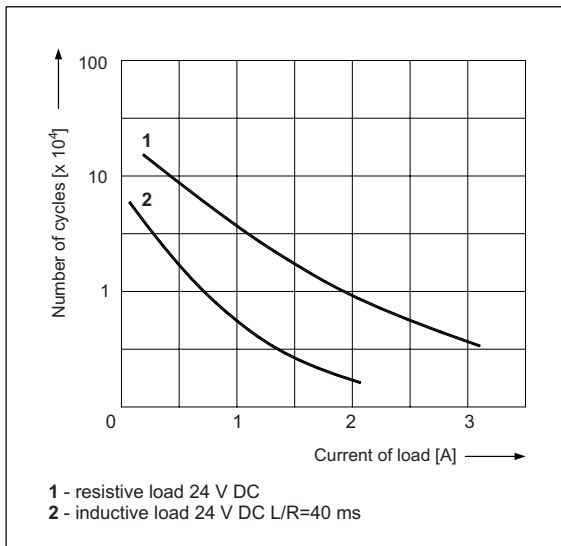

### Pinout (solder side view)

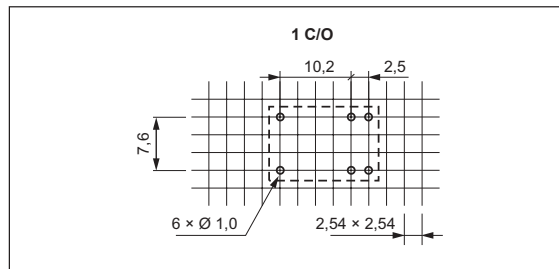

### Mounting

Relays **RSM954** are designed for direct PCB mounting.

### Ordering codes

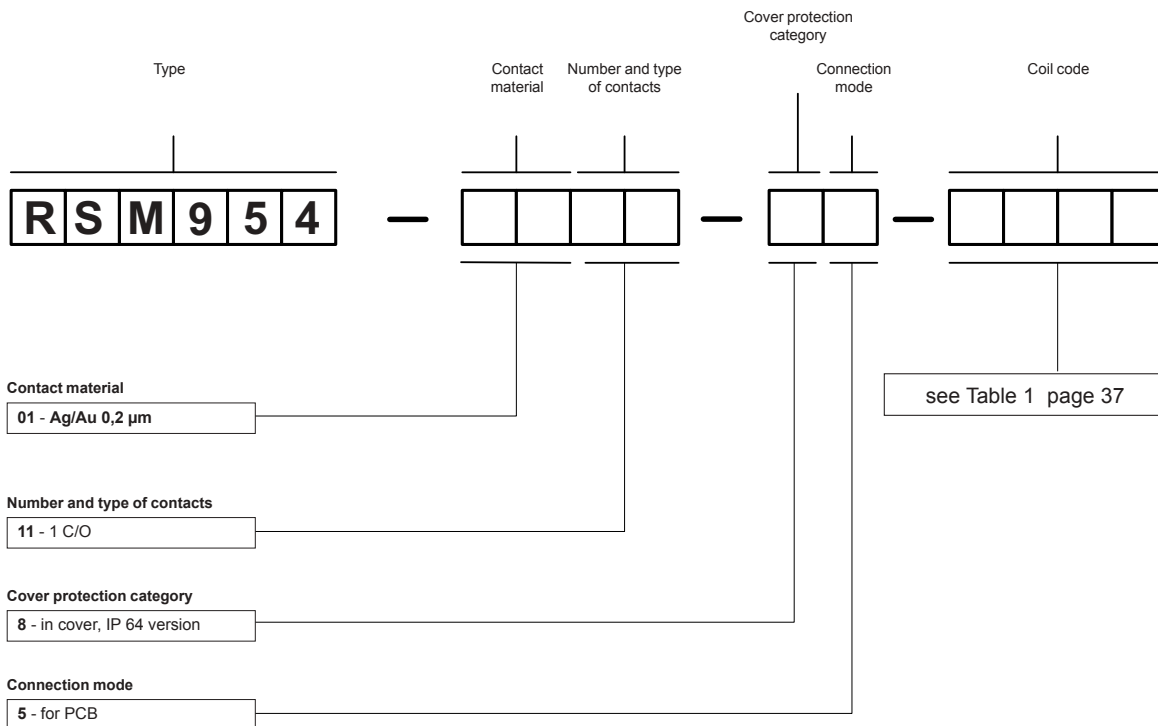

Example of ordering code:

**RSM954-0111-85-1005**

relay **RSM954**, contact material Ag/Au 0,2  $\mu$ m, with one changeover contact, in cover IP 64, for PCB, voltage version 5 V DC