

STF28-461 EMI Input Filters

28 VOLT INPUT – 0.8 AMP

FEATURES

- Fully qualified to Class H or K
- Passive components used for maximum tolerance in space environments
- -55°C to +125°C operation
- Nominal 28 V input, 0 V to 50 V operation
- Up to 0.8 A throughput current
- 55 dB attenuation typical at 500KHz
- Compliant to MIL-STD-461C CE-03
- Compatible with MIL-STD-704 A-E 28 VDC power bus



INPUT VOLTAGE AND CURRENT

Input (V)	Current (A)
28	0.8

DESCRIPTION

The STF28-461™ EMI filter module has been designed as a companion for Interpoint SMSA flyback power converters. Multiple SMSA power converters can be operated from a single filter provided the total power line current does not exceed the filter maximum rating. The STF filter will reduce the SMSA's power line reflected ripple current to within the limit of MIL-STD-461C, Method CE03. The STF filter is fabricated using thick film hybrid technology and is sealed in a metal package for space, military, aerospace and other applications requiring EMI suppression.

OPERATION

The SMSA power converter has an internal 2 μ F ceramic capacitor across its input power terminals. When the SMSA and STF filters are used together, this capacitor becomes part of the filter and forms its final LC output section. The STF filter provides both differential and common mode rejection bringing DC/DC converters into compliance with MIL-STD-461C CE03. It is designed to be used with the SMSA, SMHF, and SLH Series of converters. The STF filter can be used with multiple converters up to the rated current of the filter. For more information, contact your Interpoint representative.

For SMHF and SLH converters a 4 μ F (or greater) ceramic cap is needed between the filter and converter to complete the last inductive stage of this STF filter. This will ensure unconditional stability when used with the SMHF or SLH. The SMSA does not require this.

OPTIONAL DAMPING CIRCUIT

The optional damping circuit (Figure 2) can be used to prevent filter overshoot caused by MIL-STD-704A 80 V, or other, transients having rise times of less than 200 μ Sec. This damping can be alternately provided with a 1.50 Ω resistor in series with the filter positive input where the additional line loss can be tolerated. For transients with rise times of greater than 200 μ Sec, there is no overshoot and the damping circuit is not required.

SCREENING

The STF28-461 filter offers three screening options: Space Prototype (O), Class H, or Class K. Radiation tolerant to Radiation Hardness Assurance (RHA) levels of "-" (O) or "H", per MIL-STD-38534. Interpoint model numbers use an "O" in the RHA designator position to indicate the "-" (dash) Radiation Hardness Assurance level of MIL-PRF-38534, which is defined as "no RHA". See "Class H and K, MIL-PRF-38534 Screening" tables, for descriptions.

STF28-461 EMI Input Filters

28 VOLT INPUT – 0.8 AMP

OPERATING CONDITIONS AND CHARACTERISTICS

Input Voltage Range

- 0 to 50 VDC continuous

Lead Soldering Temperature (10 sec per lead)

- 300°C

Storage Temperature Range (Case)

- -65°C to +150°C

Case Operating Temperature (Tc)

- -55°C to +125°C full power

Derating Input/Output Current

- Derate linearly from 100% at 125°C to 0% at 135°C case.

Capacitance

- 0.045 μF max, any pin to case

Isolation

- 100 megohm minimum at 500 VDC
- Any pin to case, except case pin

MECHANICAL AND ENVIRONMENTAL

Size (maximum)

0.980 x 0.805 x 0.270 (24.89 x 20.45 x 6.86 mm)
See case A1 for dimensions.

Weight (maximum)

10.3 grams typical, 11.5 grams maximum

Screening

Space Prototype (O), Class H, or Class K
Radiation tolerant to Radiation Hardness Assurance (RHA) levels of “-” (O) or “H”, per MIL-STD-38534. Interpoint model numbers use an “O” in the RHA designator position to indicate the “-” (dash) Radiation Hardness Assurance level of MIL-PRF-38534, which is defined as “no RHA”.

See “Class H and K, MIL-PRF-38534 Screening” tables for more information. Available configurations: OO, HH, KH

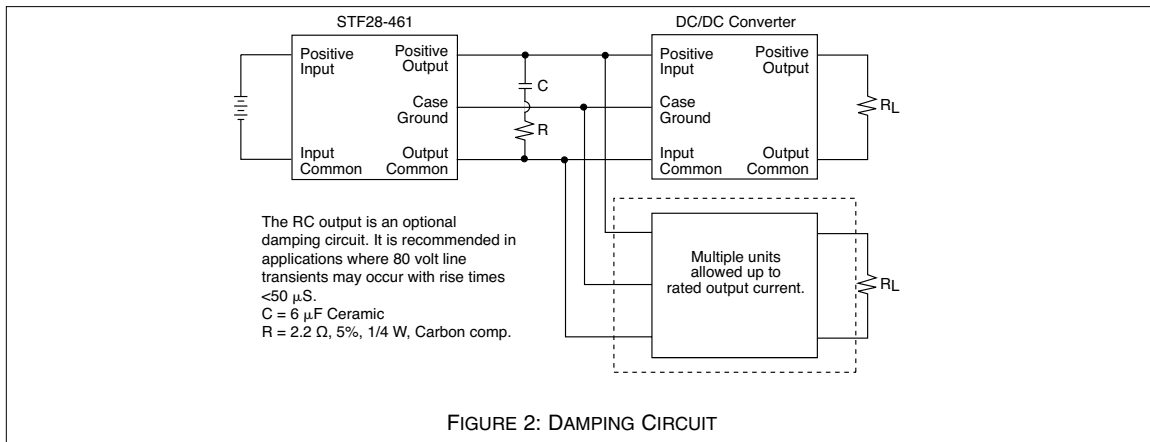
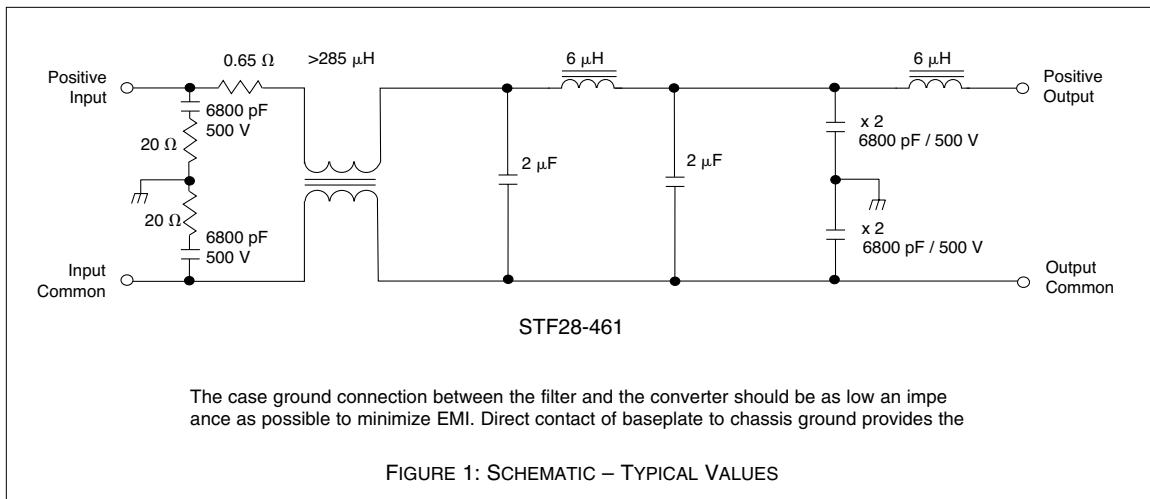

STF28-461 EMI Input Filters

28 VOLT INPUT – 0.8 AMP

PIN OUT

Pin	Designation
1	Positive Input
2, 3	Positive Output
4	Case Ground
5, 6	Output Common
7	Input Common
8	Case Ground

Squared corner and dot on top of cover indicate pin one.

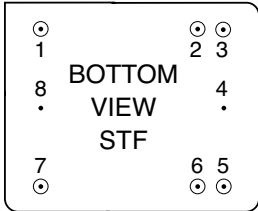

See case A1 for dimensions.

FIGURE 3: PIN OUT

STF28-461 EMI Input Filters

28 VOLT INPUT – 0.8 AMP

Electrical Characteristics: 25°C Tc, nominal Vin, unless otherwise specified.

PARAMETER	CONDITIONS	STF28-461			UNITS
		MIN	TYP	MAX	
INPUT VOLTAGE	CONTINUOUS	0	28	50	VDC
INPUT CURRENT ¹		—	—	0.80	A
NOISE REJECTION	500 kHz	50	—	—	dB
	1 MHz	50	—	—	
	5 MHz	45	—	—	
DC RESISTANCE (R _{DC})	TC = 25°C	—	—	1.2	Ω
OUTPUT VOLTAGE	STEADY STATE	$V_{OUT} = V_{IN} - I_{IN}(R_{DC})$			VDC
OUTPUT CURRENT	STEADY STATE	—	—	0.80	A
POWER DISSIPATION AT MAXIMUM CURRENT		—	—	1.15	W

Notes:

1. Guaranteed by design, not tested.

STF28-461 EMI Input Filters

28 VOLT INPUT – 0.8 AMP

Typical Performance Curves: 25°C Tc, nominal Vin, unless otherwise specified.

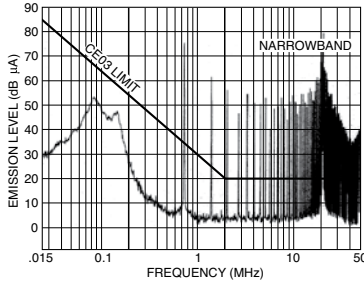

MSA2805S converter without a filter.

FIGURE 4

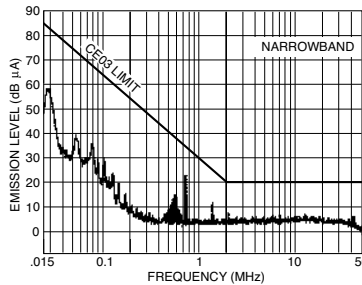

MSA2805S converter at full load with an STF28-461 EMI filter.

FIGURE 5

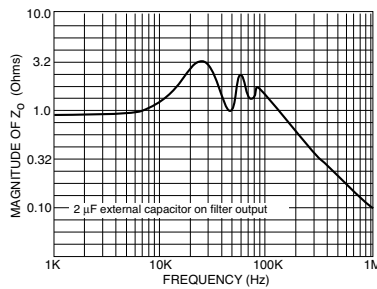

Typical output impedance (Z) with input shorted. STF28-461 EMI filter.

FIGURE 6

STF28-461 EMI Input Filter Cases

28 VOLT INPUT – 0.8 AMP

BOTTOM VIEW CASE A1

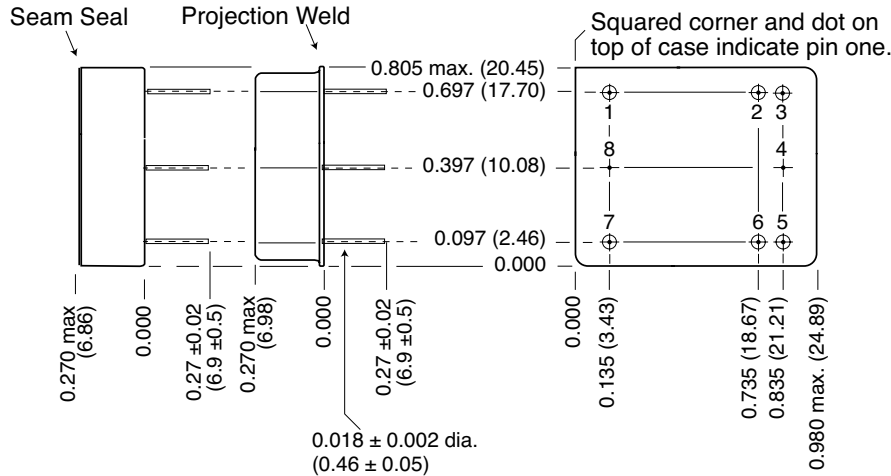

Seal hole: 0.056 ±0.002 (1.42 ±0.05)

Case dimensions in inches (mm)

Tolerance ±0.005 (0.13) for three decimal places
 ±0.01 (0.3) for two decimal places
 unless otherwise specified

CAUTION

Heat from reflow or wave soldering may damage the device.
 Solder pins individually with heat application not exceeding 300°C for 10 seconds per pin

Materials

Header Kovar/Nickel/Gold
 Cover Kovar/Nickel
 Pins Kovar/Nickel/Gold matched glass seal

Case A1, Rev C, 20060110

Please refer to the numerical dimensions for accuracy. All information is believed to be accurate, but no responsibility is assumed for errors or omissions. Interpoint reserves the right to make changes in products or specifications without notice.

Copyright © 1999-2006 Interpoint Corp. All rights reserved.

FIGURE 4: CASE A1

STF28-461 EMI Input Filters

28 VOLT INPUT – 0.8 AMP

CLASS H AND K, MIL-PRF-38534 ELEMENT EVALUATION

TEST PERFORMED (COMPONENT LEVEL)	SPACE PROTOTYPE O NON-QML ¹		CLASS H QML		CLASS K QML	
	M/S ²	P ³	M/S ²	P ³	M/S ²	P ³
	Element Electrical	yes	no	yes	yes	yes
Element Visual	no	no	yes	yes	yes	yes
Internal Visual	no	N/A	yes	N/A	yes	N/A
Temperature Cycling	no	no	no	no	yes	yes
Constant Acceleration	no	no	no	no	yes	yes
Interim Electrical	no	N/A	no	N/A	yes	N/A
Burn-in	no	N/A	no	N/A	yes	N/A
Post Burn-in Electrical	no	N/A	no	N/A	yes	N/A
Steady State Life	no	N/A	no	N/A	yes	N/A
Voltage Conditioning Aging	N/A	no	N/A	no	N/A	yes
Visual Inspection	no	no	N/A	no	N/A	yes
Final Electrical	no	no	yes	yes	yes	yes
Wire Bond Evaluation ⁴	no	no	yes	yes	yes	yes
SEM	no	N/A	no	N/A	yes	N/A
SLAM™/C-SAM: Input capacitors only (Add'l test, not req. by H or K)	no	no	no	yes	no	yes

Notes:

1. Non-QML products do not meet all of the requirements of MIL-PRF-38534.
2. M/S = Active components (Microcircuit and Semiconductor Die)
3. P = Passive components
4. Not applicable to EMI filters that have no wirebonds.

Definitions:

Element Evaluation: Component testing/screening per MIL-STD-883 as determined by MIL-PRF-38534
SEM: Scanning Electron Microscopy
SLAM™: Scanning Laser Acoustic Microscopy
C-SAM: C - Mode Scanning Acoustic Microscopy

STF28-461 EMI Input Filters

28 VOLT INPUT – 0.8 AMP

CLASS H AND K, MIL-PRF-38534 ENVIRONMENTAL SCREENING

TEST PERFORMED (END ITEM LEVEL)	SPACE PROTOTYPE O NON-QML ¹	CLASS H, QML	CLASS K, QML
Non-destruct bond pull ² Method 2023	no	yes ³	yes
Pre-cap Inspection Method 2017, 2032	yes	yes	yes
Temperature Cycle (10 times) Method 1010, Cond. C, -65°C to 150°C, ambient	yes	yes	yes
Constant Acceleration Method 2001, 3000 g	yes	yes	yes
PIND Test Method 2020, Cond. A	no	yes ³	yes
Pre burn-in test	yes	yes	yes
Burn-in Method 1015, 125°C case, typical			
96 hours	yes	no	no
160 hours	no	yes	no
2 x 160 hour (includes mid BI test)	no	no	yes
Final electrical test MIL-PRF-38534 Group A, Subgroups 1 through 6 -55°C, +25°C, +125°C case	yes	yes	yes
Radiography Method 2012	N/A	N/A	yes
Post Radiography Electrical Test Room temperature	N/A	N/A	yes ³
Hermeticity test Fine Leak, Method 1014, Cond. A	yes	yes	yes
Gross Leak, Method 1014, Cond. C	yes	yes	yes
Final visual inspection Method 2009	yes	yes	yes

Test methods are referenced to MIL-STD-883 as determined by MIL-PRF-38534.

Notes:

1. Space Prototype (O), non-QML products, do not meet all of the requirements of MIL-PRF-38534.
2. Not applicable to EMI filters that have no wirebonds.
3. Not required by DSCC but performed to assure product quality.

STF28-461 EMI Input Filters

28 VOLT INPUT – 0.8 AMP

CLASS H AND K, MIL-PRF-38534 RADIATION ASSURANCE

PRODUCT LEVEL AVAILABILITY	ENVIRONMENTAL SCREENING LEVELS		
	SPACE PROTOTYPE O NON-QML ³	CLASS H QML	CLASS K QML
RADIATION HARDNESS ASSURANCE LEVELS			
O² : Standard, no radiation guarantee	OO	HO	N/A
H^{1, 5} : Radiation tolerant – Tested lots Up to 1,000 K Rads (Si) total dose	N/A	HH ⁴	KH ⁴

Notes:

1. Our EMI filters are designed exclusively with passive components providing maximum tolerance for space environment requirements.
2. Interpoint model numbers use an "O" in the RHA designator position to indicate the "-" (dash) Radiation Hardness Assurance level of MIL-PRF-38534, which is defined as "no RHA".
3. Space Prototype (O), non-QML products, do not meet all of the requirements of MIL-PRF-38534.
4. Redmond site, Interpoint, has a Radiation Hardness assurance plan on file with DSCC. Our SMD products with RHA "H" code meet DSCC requirements.
5. Space filters are only available with Radiation Hardness Assurance (RHA) levels of "O" and "H".