

Dual Band Dipole 824-896/1850-1990MHz TNC Spin Connector

Pulse Part Number: SPDA17850/1900



Electrical Specifications

Frequency		806-925/ 1800-2170 MHz
Nominal Impedance [Ω]		50
VSWR		2:1 Max
Gain (806,925)		0 dBi \pm .5 dB
Gain (825-900)		1.5 dBi \pm .5 dB
Gain (1800-2170)		1.5 dBi \pm .5 dB
Radiation Pattern, 3 dB Beamwidth	Horizontal Plane	Omni
	Vertical Plane (806-900)	90 $^{\circ}$ \pm 2 $^{\circ}$
	Vertical Plane (925)	82 $^{\circ}$ \pm 2 $^{\circ}$
	Vertical Plane (1800)	110 $^{\circ}$ \pm 2 $^{\circ}$
	Vertical Plane (1900)	90 $^{\circ}$ \pm 2 $^{\circ}$
	Vertical Plane (2000)	77 $^{\circ}$ \pm 2 $^{\circ}$
	Vertical Plane (2100)	71 $^{\circ}$ \pm 2 $^{\circ}$
	Vertical Plane (2170)	62 $^{\circ}$ \pm 2 $^{\circ}$
Polarization		Vertical
Power Withstanding [W]		3
Connector Type		TNC

Mechanical and Environmental Specifications

Plastic radome	Flammability Rating	Color	Weight [g]	Overall Length [inches]	Operating Temperature [$^{\circ}$ C]
Bayblend FR 2010 (PC+ABS)	UL94 V-0	Black	36	6.74	-30 to +70

Pulse Finland Oy

Takatie 6
90440 Kempele, Finland
Tel: +358 207 935 500
Fax: +358 207 935 501
www.pulseeng.com/antennas



© 2008. All Rights Reserved.

Dual Band Dipole 824-896/1850-1990MHz TNC Spin Connector

Pulse Part Number: SPDA17850/1900

Curves

VSWR

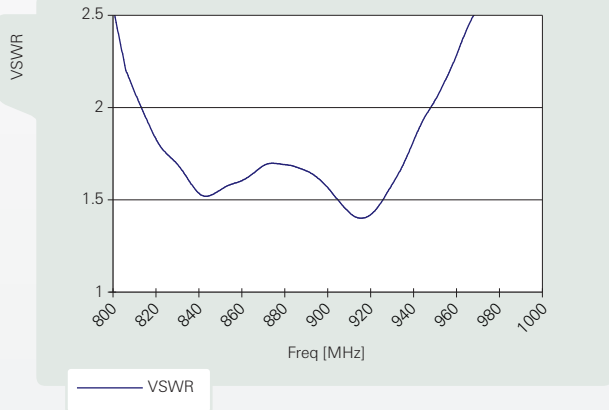

Radiating Element Average Gain

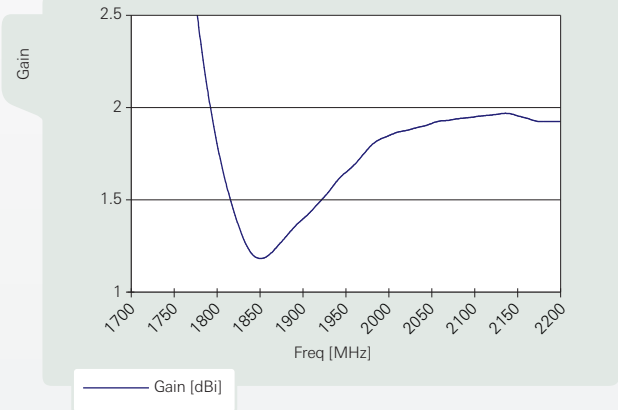

H & E plane 806

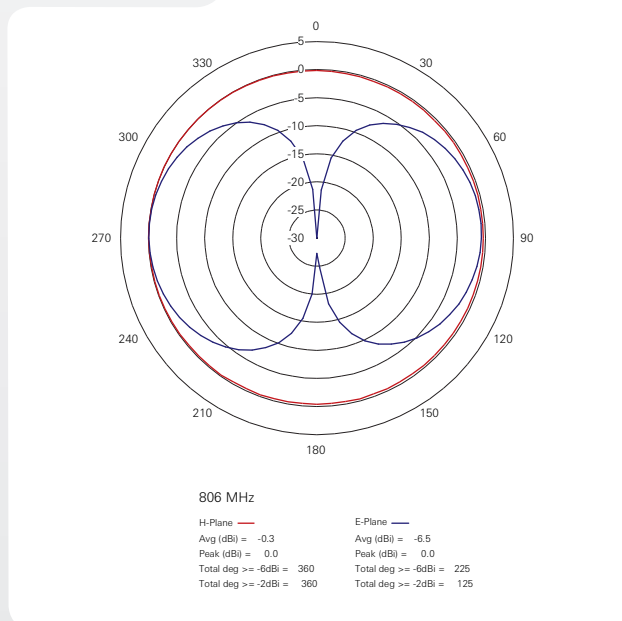

H & E plane 825



Pulse Finland Oy

Takatie 6
90440 Kempele, Finland
Tel: +358 207 935 500
Fax: +358 207 935 501
www.pulseeng.com/antennas



© 2008. All Rights Reserved.

Dual Band Dipole 824-896/1850-1990MHz TNC Spin Connector

Pulse Part Number: SPDA17850/1900

Curves

H & E plane 860

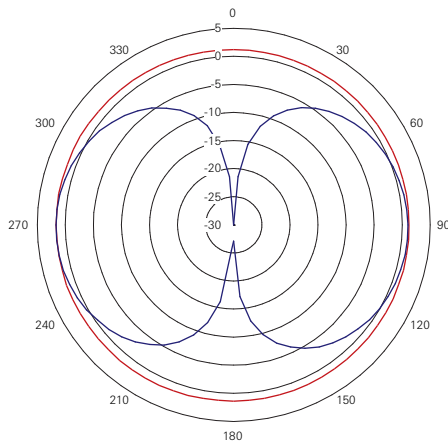

860 MHz

H-Plane	—	E-Plane	—
Avg (dBi)	= 1.4	Avg (dBi)	= -5.0
Peak (dBi)	= 1.7	Peak (dBi)	= 1.7
Total deg >= -6dBi	= 360	Total deg >= -6dBi	= 250
Total deg >= -2dBi	= 360	Total deg >= -2dBi	= 180

H & E plane 900

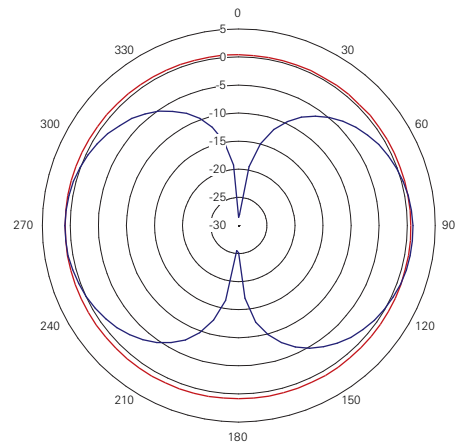

900 MHz

H-Plane	—	E-Plane	—
Avg (dBi)	= 0.7	Avg (dBi)	= -5.6
Peak (dBi)	= 1.0	Peak (dBi)	= 1.0
Total deg >= -6dBi	= 360	Total deg >= -6dBi	= 235
Total deg >= -2dBi	= 360	Total deg >= -2dBi	= 165

H & E plane 925

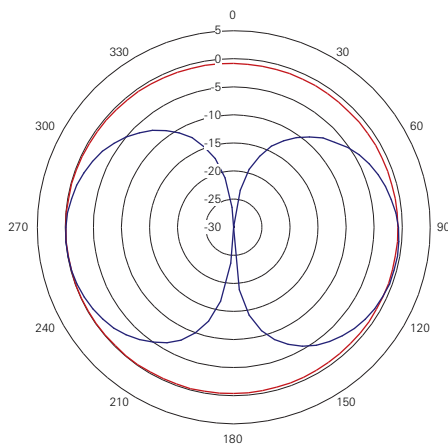

925 MHz

H-Plane	—	E-Plane	—
Avg (dBi)	= -0.5	Avg (dBi)	= -7.6
Peak (dBi)	= 0.0	Peak (dBi)	= 0.0
Total deg >= -6dBi	= 360	Total deg >= -6dBi	= 200
Total deg >= -2dBi	= 360	Total deg >= -2dBi	= 115

H & E plane 1800

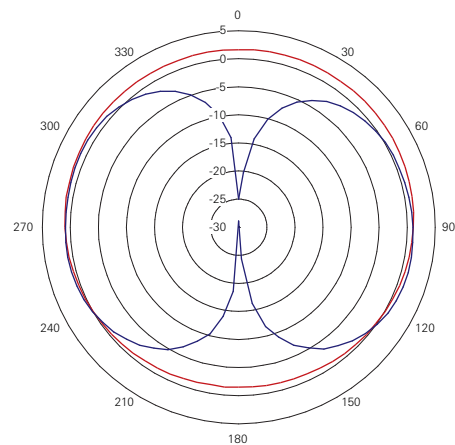

1800 MHz

H-Plane	—	E-Plane	—
Avg (dBi)	= 0.6	Avg (dBi)	= -4.1
Peak (dBi)	= 1.7	Peak (dBi)	= 1.3
Total deg >= -6dBi	= 360	Total deg >= -6dBi	= 265
Total deg >= -2dBi	= 360	Total deg >= -2dBi	= 205

Pulse Finland Oy

Takatie 6

90440 Kempele, Finland

Tel: +358 207 935 500

Fax: +358 207 935 501

www.pulseeng.com/antennas



© 2008. All Rights Reserved.

Dual Band Dipole 824-896/1850-1990MHz TNC Spin Connector

Pulse Part Number: SPDA17850/1900

Curves

H & E plane 1900

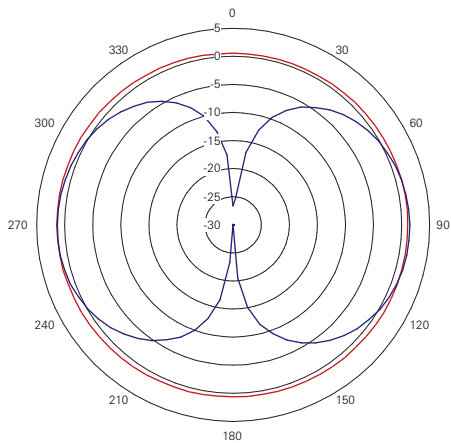

1900 MHz

H-Plane —	E-Plane —
Avg (dBi) = 0.9	Avg (dBi) = -5.0
Peak (dBi) = 1.4	Peak (dBi) = 1.5
Total deg >= -6dBi = 360	Total deg >= -6dBi = 245
Total deg >= -2dBi = 360	Total deg >= -2dBi = 175

H & E plane 2000

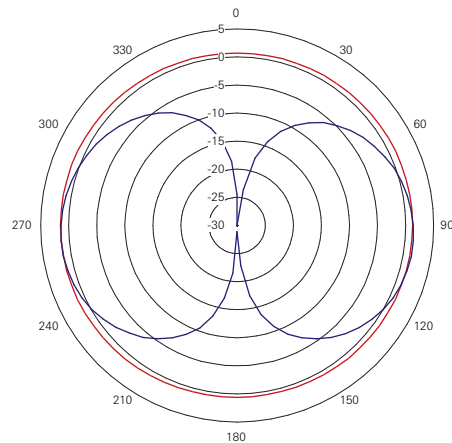

2000 MHz

H-Plane —	E-Plane —
Avg (dBi) = 1.0	Avg (dBi) = -6.2
Peak (dBi) = 1.5	Peak (dBi) = 1.5
Total deg >= -6dBi = 360	Total deg >= -6dBi = 220
Total deg >= -2dBi = 360	Total deg >= -2dBi = 155

H & E plane 2100

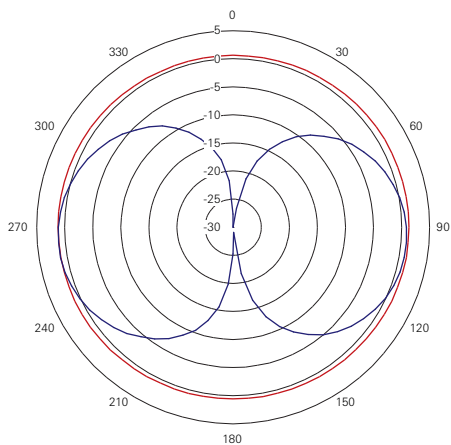

2100 MHz

H-Plane —	E-Plane —
Avg (dBi) = 0.9	Avg (dBi) = -7.6
Peak (dBi) = 1.3	Peak (dBi) = 1.2
Total deg >= -6dBi = 360	Total deg >= -6dBi = 200
Total deg >= -2dBi = 360	Total deg >= -2dBi = 125

H & E plane 2170

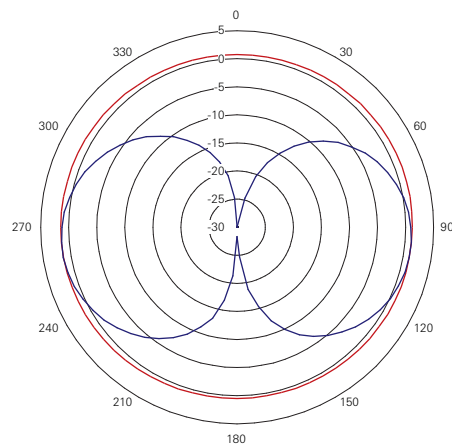

2170 MHz

H-Plane —	E-Plane —
Avg (dBi) = 1.0	Avg (dBi) = -8.1
Peak (dBi) = 1.4	Peak (dBi) = 1.4
Total deg >= -6dBi = 360	Total deg >= -6dBi = 190
Total deg >= -2dBi = 360	Total deg >= -2dBi = 120

Pulse Finland Oy

Takatie 6
90440 Kempele, Finland

Tel: +358 207 935 500

Fax: +358 207 935 501

www.pulseeng.com/antennas



© 2008. All Rights Reserved.

Dual Band Dipole 824-896/1850-1990MHz TNC Spin Connector

Pulse Part Number: SPDA17850/1900

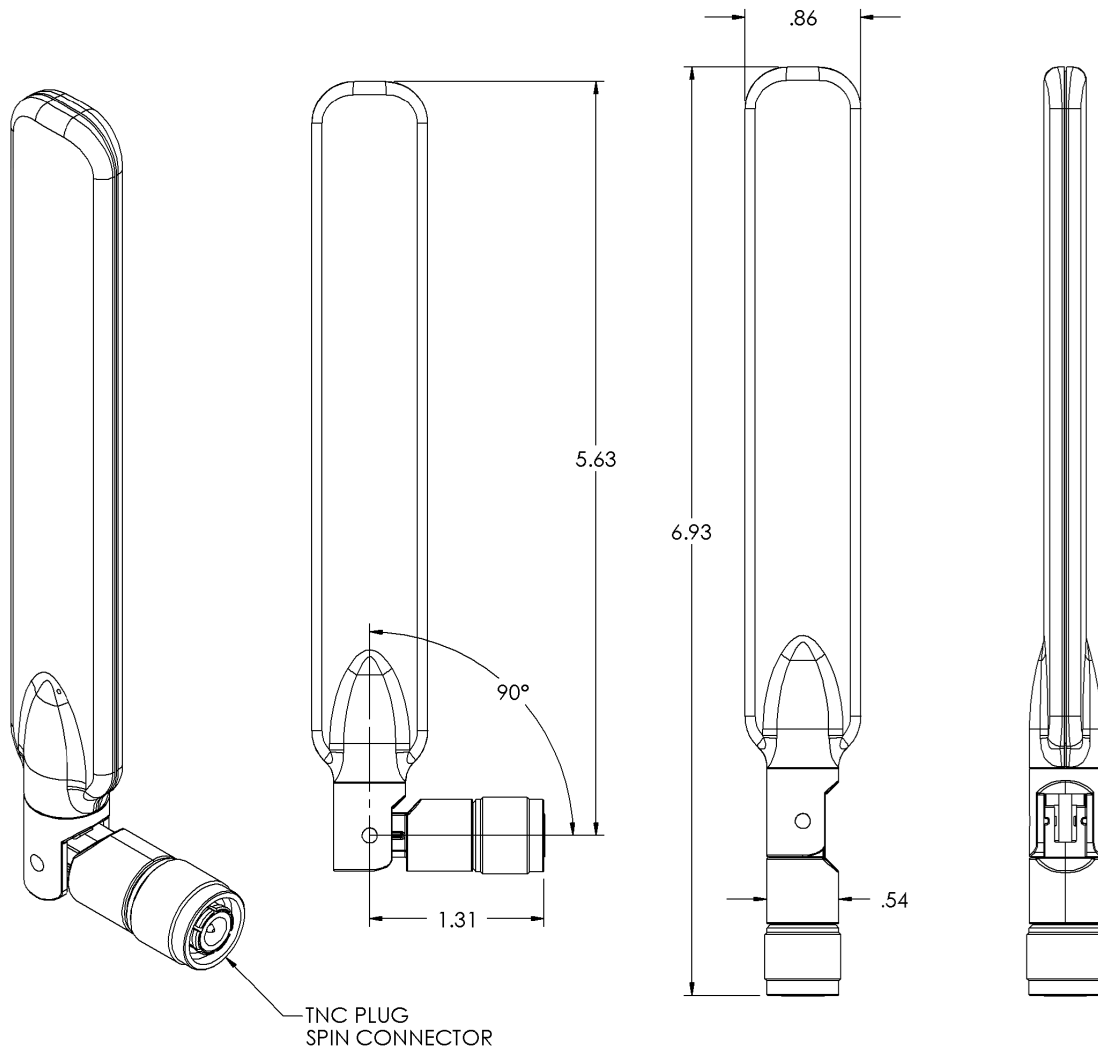

All dimensions are in inches

Pulse Finland Oy

Takatie 6

90440 Kempele, Finland

Tel: +358 207 935 500

Fax: +358 207 935 501

www.pulseeng.com/antennas



© 2008. All Rights Reserved.