

Datasheet

1.25 Gbps Single Fiber 38 km Bidirectional SFP Transceivers

SFP-GD-BD34, SFP-GD-BD34TH, SFP-GD-BD43 and SFP-GD-BD43TH



Features

- SFP transceiver
- Data Rates 1.25 Gbps
- Protocol:
 - Gigabit Ethernet
- Single-mode fiber
- Single fiber, bi-directional
- Two wavelengths:
 - 1310 nm or 1490 nm
- 12 to 38 km
- Simplex LC connector
- Digital Diagnostics (SFF-8472)
- Hot-swap
- Industrial temperature models available
- Compliances (see last page for details)

Overview

Small Form-Factor Pluggable (SFP) interfaces from MRV Communications provide flexible high speed links in a small industry standard package. They deliver the deployment options and inventory control that network administrators demand for growing networks.

SFPs are designed to Multi-Source Agreement (MSA) standards to ensure network equipment compatibility. They are a perfect addition to MRV's extensive lines of networking equipment.

Visit the MRV website at www.mrv.com or contact your nearest authorized MRV Communications dealer for more information.

Specifications Overview

Data Rate		1.25 Gbps
Tx Wavelength:	SFP-GD-BD34	1310 nm
	SFP-GD-BD43	1490 nm
Tx Power (Minimum)		-5 dBm
Tx Disable		Yes
Rx Wavelength:	SFP-GD-BD34	1480 to 1580 nm
	SFP-GD-BD43	1260 to 1360 nm
Rx Sensitivity		-24 dBm
Rx Saturation		-3 dBm
Rx Damage Threshold		0 dBm
Operating Temperature Range		-5 to 70 °C
Operating Temperature Range (TH Models)		-40 to 85 °C
Power Consumption		1 Watt

Datasheet

Transmitter Specifications (Optical)

Parameter	Symbol	Min	Max	Unit	Notes
Optical Power	P _{Op}	-5	0	dBm	-
Optical Crosstalk	XT	-	-40	dB	-
Average Launch Power Tx_Off	P _{Off}	-	-45	dBm	-
Extinction Ratio	ER	9	-	dB	-
Eye Mask	Compliant with IEEE 802.3ah				
Optical Rise/Fall Time (20%~80% values)	t _r /t _f	-	260	ps	-
Wavelength for SFP-GD-BD34	λ	1260	1360	nm	-
Wavelength for SFP-GD-BD43	λ	1480	1500	nm	-
Relative Intensity Noise	RIN	-	-120	dB/Hz	-
Transmitter Reflectance	-	-	-12	dB	-
Reflection Tolerance	rp	-	12	dB	-

Receiver Specifications (Optical)

Parameter	Symbol	Min	Max	Unit	Notes
Receiver Power Low	R _{sens,low}	-	-24	dBm	1
Receiver Power High	R _{sens,high}	-3	-	dBm	1
Damage Threshold For Receiver	P _{in, damage}	0	-	dBm	-
Wavelength for SFP-GD-BD34	λ	1480	1580	nm	-
Wavelength for SFP-GD-BD43	λ	1260	1360	nm	-
Receiver Reflectance	RX _r	-	-12	dB	-
LOS Assert	LOS _A	-45	-	dBm	-
LOS De-assert	LOS _D	-	-24	dBm	-
LOS Hysteresis	-	0.5	-	dB	-

Notes: 1. Measured at 10⁻¹² BER, PRBS 2⁷-1

Digital Diagnostics

Parameter	Range	Accuracy	Unit	Calibration	Formula
Temperature	-5 to 70	± 3	°C	External	Tc(C) = Tslope* <i>T</i> ad (16 bit signed twos complement value) + Toffset
Temperature (TH Models)	-40 to 85	± 3	°C	External	Tc(C) = Tslope* <i>T</i> ad (16 bit signed twos complement value) + Toffset
Voltage	0 to V _{CC}	± 0.1	V	External	V(Volts) = Vslope* <i>V</i> ad (16 bit unsigned integer) + Voffset
Bias Current	0 to 120	± 5	mA	External	I(mA) = Islope * <i>I</i> ad (16 bit unsigned integer) + Ioffset
TX Power	-5 to 0	± 3 dB	dBm	External	Tx_PWR(μW) = Tx_PWRslope*Tx_PWRad (16 bit unsigned integer) + Tx_PWRoffset
RX Power	-24 to -3	± 3 dB	dBm	External	RX_PWR(μW)=A0+A1*x+A2*x^2+A3*x^3+A4*x^4

Datasheet

General Operating Conditions

Parameter	Symbol	Min.	Max.	Unit	Notes
Supply Voltage	V_{CC}	3.135	3.465	V	-
Total Current	I_{CC}	-	300	mA	-
Power Supply Noise Rejection	PSR	100	-	mV _{p-p}	-
Operating Case Temperature	T_{opr}	-5	70	°C	-
Operating Case Temperature (TH Models)	T_{opr}	-40	85	°C	-
Storage Temperature	T_{stg}	-40	85	°C	-
Data Rate	DR	-	1250	Mbps	-

Transmitter Specifications (Electrical)

Parameter	Symbol	Min.	Max.	Unit	Notes
Input Differential Impedance	R_{in}	80	120	Ω	-
PECL Single Ended Data Input Swing	$V_{in, p-p}$	250	1200	mV	-
TxFault_Fault	V_{fault}	2	V_{CC}	V	-
TxFault_Normal	V_{normal}	V _{ee}	V _{ee} + 0.5	V	-
TxDisable_Disable	V_d	2	V_{CC}	V	-
TxDisable_Enable	V_{en}	V _{ee}	V _{ee} + 0.8	V	-

Receiver Specifications (Electrical)

Parameter	Symbol	Min.	Max.	Unit	Notes
PECL Single Ended Data Output Swing	$V_{out, p-p}$	185	800	mV	-
Data Output Rise/Fall Time	t_r, t_f	-	500	ps	-

Electrical Specifications and Timing

Parameter	Symbol	Min	Max	Unit	Notes
Tx Disable Negate Time	t_{on}	-	1	ms	-
Tx Disable Assert Time	t_{off}	-	10	μ s	-
Time to Initialize, Including Reset of Tx Fault	t_{init}	-	300	ms	-
Tx Fault Assert Time	t_{fault}	-	100	μ s	-
Tx Disable to Reset	t_{reset}	10	-	μ s	-
LOS Assert Time	$t_{loss_{on}}$	-	100	μ s	-
LOS De-Assert Time	$t_{loss_{off}}$	-	100	μ s	-
Serial ID Clock Rate	f_{serial_clock}	-	100	kHz	-
RX_LOS Voltage (High)	Rx_LOS_H	2	-	V	-
RX_LOS Voltage (Low)	Rx_LOS_L	-	0.8	V	-
LOS Output Voltage-Fault	$V_{Los_{fault}}$	2	V_{CC}	V	-
LOS Output Voltage-Normal	$V_{Los_{normal}}$	V _{ee}	V _{ee} + 0.5	V	-
MOD_DEF (0:2)-High	V_H	2	V_{CC}	V	-
MOD_DEF (0:2)-Low	V_L	V _{ee}	V _{ee} + 0.5	V	-

Datasheet

Pin	Function	Name / Description	Notes
1	V _{ee} T	Transmitter Ground	-
2	TX_FAULT	Open Collector	-
3	TX_DISABLE	Internally Pulled High	-
4	MOD_DEF2	Serial Data Input	-
5	MOD_DEF1	Serial Clock Input	-
6	MOD_DEF0	Internally Grounded	-
7	NC	Not Connected	-
8	LOS	Open Collector	-
9	V _{ee} R	Receiver Ground	-
10	V _{ee} R	Receiver Ground	-
11	V _{ee} R	Receiver Ground	-
12	RXD-	Receiver Data Negative	-
13	RXD+	Receiver Data Positive	-
14	V _{ee} R	Receiver Ground	-
15	V _{cc} R	Receiver Power	-
16	V _{cc} T	Transmitter Power	-
17	V _{ee} T	Transmitter Ground	-
18	TXD+	Transmitter Data Positive	-
19	TXD-	Transmitter Data Negative	-
20	V _{ee} T	Transmitter Ground	-

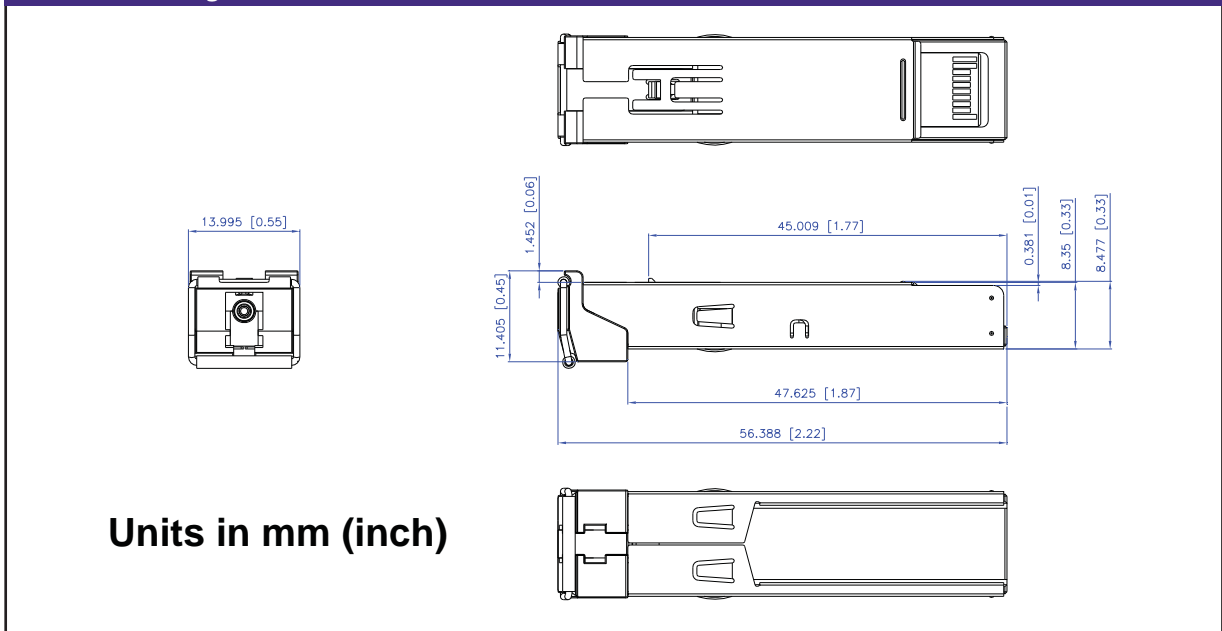
Outline Drawing

Datasheet

Ordering Information

Model	Description	Data Rate (Gbps)	Wavelength (nm)		Connector Type	Bail Latch Color	Distance Range (km)
			Tx	Rx			
SFP-GD-BD34	SFP Bidirectional Transceiver Single Fiber, Single-Mode with Digital Diagnostics	1.25	1310	1490	Simplex LC	Blue	12 - 38
SFP-GD-BD34TH	SFP Bidirectional Transceiver Single Fiber, Single-Mode with Digital Diagnostics, <i>Temperature Hardened</i>	1.25	1310	1490	Simplex LC	Blue	12 - 38
SFP-GD-BD43	SFP Bidirectional Transceiver Single Fiber, Single-Mode with Digital Diagnostics	1.25	1490	1310	Simplex LC	Purple	12 - 38
SFP-GD-BD43TH	SFP Bidirectional Transceiver Single Fiber, Single-Mode with Digital Diagnostics, <i>Temperature Hardened</i>	1.25	1490	1310	Simplex LC	Purple	12 - 38

Regulatory and Industry Compliances

Class 1 Laser Product, Complies with 21CFR 1040.10, 1040.11 and EN 60825;
 Certified by one or more of the following agencies: TÜV, UL, CSA;
 RoHS Directive; China RoHS; California RoHS Law, REACH Directive SVHC; WEEE Directive
 The Quality Management System is certified to ISO 9001 by QMI-SAI Global
 The Environmental Management System is in compliance with ISO 14001

Warnings

Handling Precautions: This device is susceptible to damage as a result of electrostatic discharge (ESD). A static free environment is highly recommended. Follow guidelines according to proper ESD procedures.

Laser Safety: Radiation emitted by laser devices can be dangerous to human eyes. Avoid eye exposure to direct or indirect radiation.

MRV has more than 50 offices throughout the world. Addresses, phone numbers and fax numbers are listed at www.mrv.com. Please e-mail us at sales@mrv.com or call us for assistance.

MRV Los Angeles
 20415 Nordhoff St.
 Chatsworth, CA 91311
 800-338-5316
 818-773-0900

MRV Boston
 295 Foster St.
 Littleton, MA 01460
 800-338-5316
 978-952-4700

MRV International
 Business Park Moerfelden
 Waldeckerstrasse 13
 64546 Moerfelden-Walldorf
 Germany
 Tel. (49) 6105/2070
 Fax (49) 6105/207-100

All statements, technical information and recommendations related to the products herein are based upon information believed to be reliable or accurate. However, the accuracy or completeness thereof is not guaranteed, and no responsibility is assumed for any inaccuracies. Please contact MRV Communications for more information. MRV Communications and the MRV Communications logo are trademarks of MRV Communications, Inc. Other trademarks are the property of their respective holders.