

Relay data

- PCB relay with forcibly guided contacts
- Protective separation between control and load circuit (leakage and creepage distance > 8mm)
- EN 50205, type A
- Double and reinforced insulation between the contacts
- Contact mounting: SIS212 2NO/1NC
- Small external dimensions
- Mean coil power 0,6W

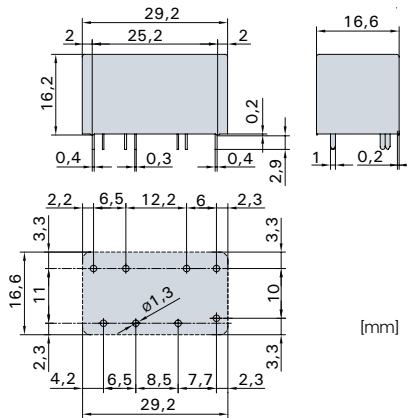

Contact material	AgCuNi+0,2-0,4µm Au
Type of contact	Single contact
Rated switching capacity	250VAC 6A AC1 1'500VA
Electr. life AC1 (360 cycles/h)	approx. 100'000
Inrush current max.	30A for 20ms
Switching voltage range	5 to 440VDC/VAC
Switching current range*	5mA to 6A
Switching capacity range*	60mW to 1'500W (VA)
Contact resistance (as delivered)	≤ 100mΩ

* Guide values

Standard coils for direct current
(other voltages on request)

Nominal voltage VDC	Min. pick-up voltage at 20°C	Drop-out voltage at 20°C	Nominal current in mA	Resistance in Ohm at 20 °C	Tolerance in %
5	≤ 3,5	≥ 0,5	120,0	41,5	± 10
9	≤ 6,3	≥ 0,9	66,6	135	± 10
12	≤ 8,4	≥ 1,2	50,0	240	± 10
18	≤ 12,6	≥ 1,8	33,3	540	± 10
24	≤ 16,8	≥ 2,4	25,0	960	± 10
48	≤ 33,6	≥ 4,8	12,5	3'840	± 10
60	≤ 42,0	≥ 6,0	10,0	6'000	± 13
110	≤ 77,0	≥ 11,0	5,4	20'150	± 15

Ordering example

SIS 2 1 2 . S ZGR009 Wash-resistant, RT III
Special design / sensitive coil
Coil voltage
Soldering tags
Number of NC contacts
Number of NO contacts
Type designation

General data

Circuit diagram (view on relay upper side)

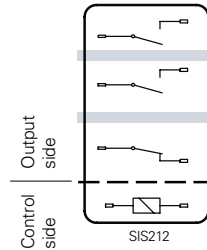

--- Basic insulation
--- Double or reinforced insulation

Mechanical life	> 10 x 10 ⁶ operations
Switching frequency, mechanical	15Hz
Response time (all NO closed) typically	10ms
Drop-out time** (all NC closed) typically	3ms
Bounce time of NO contact typically	2ms
Bounce time of NC contact typically	15ms
Shock resistance	NO contact 30g NC contact 10g
Vibration resistance	NO contact 20g NC contact 5g
Test voltage coil/control contact	2'500Veff 1min
Test voltage output contacts as against each other	4'000Veff 1min
Test voltage contact open	1'500Veff 1min
Insulation resistance at Up 500V	10 ⁶ Ω
Creeping resistance	CTI 175
Weight	approx. 20g
Mounting position	any
Ambient temperature	-40°C to +70°C
Type of protection	RT II / RT III optionally
Solder bath temperature	270°C/5s
Thermal resistance	55K/W
Temperature limit for coil	120°C
Pollution degree	3
Overvoltage category	III
Resistance to short circuiting	1'000A SCPD 6A gG (pre-fuse)

** without spark suppression

Insulation terms

Coil to control contacts: Basic insulation
Coil/control contacts to output contacts: Double or reinforced insulation > 8mm

Tests, regulations

Approvals SEV, UL, cUL, TÜV
Insulation class VDE 0110 / group C 250VAC
Protection class II VDE 0106
Fire protection requirements UL 94 / V0

Diagrammes

Contact lifetime

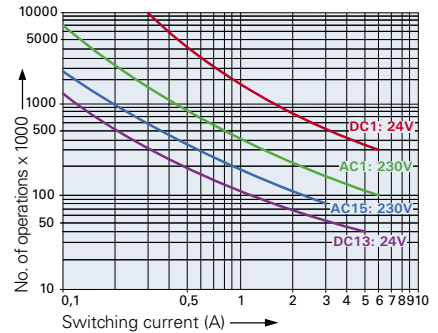

Max. switching characteristics (determined acc. to DIN EN 60947-4-1 / EN 60947-5-1):

- AC 1: 250V/6A
- AC 15: 230V/3A
- DC 1: 24V/6A
- DC 13: 24V/5A/0,1 Hz
- UL 508: B300 / R300

Maximal contact load at AC 1 with 230V:
2 contacts each with 6A

Load limit curve with direct current

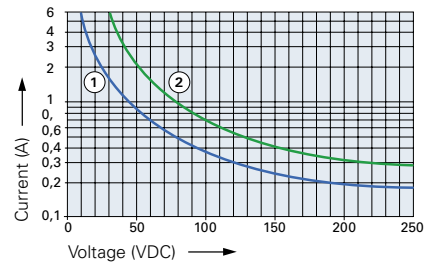

- 1) Inductive load, L/R 40 ms
- 2) Resistive load

Excitation voltage range

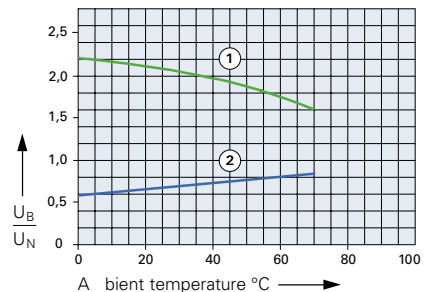

- 1) Max. excitation voltage with contact load ≤ 2A
- 2) Min. excitation voltage (guaranteed values) without previous operation

No heat accumulation due to intrinsic heating of other components.
Continuous duty 100%.



American Electronic Components, Inc.

1101 Lafayette Street, Elkhart, IN 46516, Tel: (574) 295-6330, Fax: (574) 293-8013, sales@aecsensors.com