

FEATURES:

- HIGH POWER
P_{1dB} = 36.5 dBm at 5.9 GHz to 6.4 GHz
- BROAD BAND INTERNALLY MATCHED
- HIGH GAIN
G_{1dB} = 8.5 dB at 5.9 GHz to 6.4 GHz
- HERMETICALLY SEALED PACKAGE

RF PERFORMANCE SPECIFICATIONS (Ta = 25°C)

CHARACTERISTICS	SYMBOL	CONDITION	UNIT	MIN.	TYP.	MAX.
Output Power at 1 dB Compression Point	P _{1dB}	V _{DS} = 10V f = 5.9~6.4GHz	dBm	36.0	36.5	-
Power Gain at 1 dB Compression Point	G _{1dB}		dB	8.0	8.5	-
Drain Current	I _{DS}		A	-	1.1	1.5
Power Added Efficiency	η _{add}		%	-	35	-
Channel Temperature Rise	ΔT _{ch}	V _{DS} × I _{DS} × R _{th(c-c)}	°C	-	-	80

ELECTRICAL CHARACTERISTICS (Ta = 25°C)

CHARACTERISTICS	SYMBOL	CONDITION	UNIT	MIN.	TYP.	MAX.
Trans-conductance	gm	V _{DS} = 3V I _{DS} = 1.5A	ms	-	900	-
Pinch-off Voltage	V _{GSoff}	V _{DS} = 3V I _{DS} = 20mA	V	-2.0	-3.5	-5.0
Saturated Drain Current	I _{DSS}	V _{DS} = 3V V _{GS} = 0V	A	-	2.9	3.8
Gate-Source Breakdown Voltage	V _{GS0}	I _{GS} = -60 μA	V	-5	-	-
Thermal Resistance	R _{th(c-c)}	Channel to Case	°C/W	-	4.0	6.0

- ★ The information contained herein is presented only as a guides for the applications of our products. No responsibility is assumed by TOSHIBA for any infringements of patents or other rights of the third parties which may result from its use. No license is granted by implication or otherwise under any patent or patent rights of TOSHIBA or others.
- ★ The information contained herein may be changed without prior notice. It is therefore advisable to contact TOSHIBA before proceeding with the design of equipment incorporating this product.

TIM5964-4A

ABSOLUTE MAXIMUM RATINGS (Ta = 25°C)

CHARACTERISTIC	SYMBOL	UNIT	RATING
Drain=Source Voltage	V _{DS}	V	15
Gate=Source Voltage	V _{GS}	V	-5
Drain Current	I _{DS}	A	4
Total Power Dissipation (Tc=25°C)	P _T	W	20
Channel Temperature	T _{ch}	°C	175
Storage Temperature	T _{stg}	°C	-65~175

PACKAGE OUTLINE (2-11D1B)

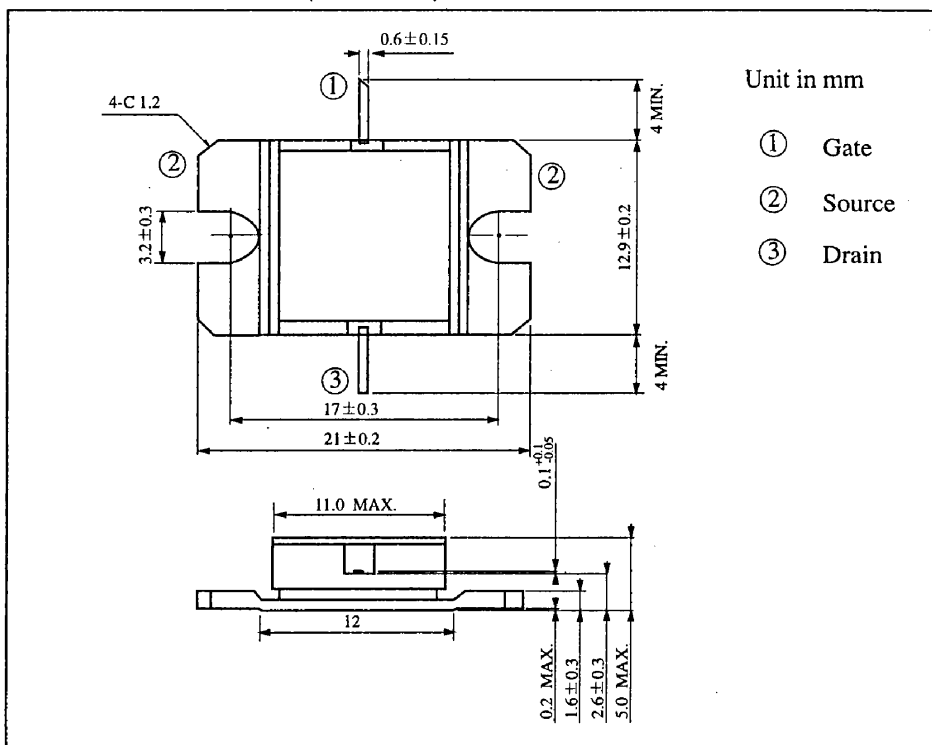

HANDLING PRECAUTIONS FOR PACKAGED TYPE

Soldering iron should be grounded and the operating time should not exceed 10 seconds at 260°C.

TIM5964-4A

RF PERFORMANCES

Output Power vs. Frequency

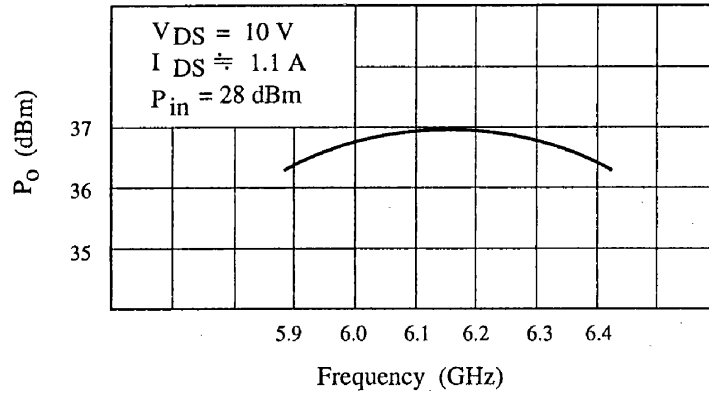

Output Power vs. Input Power

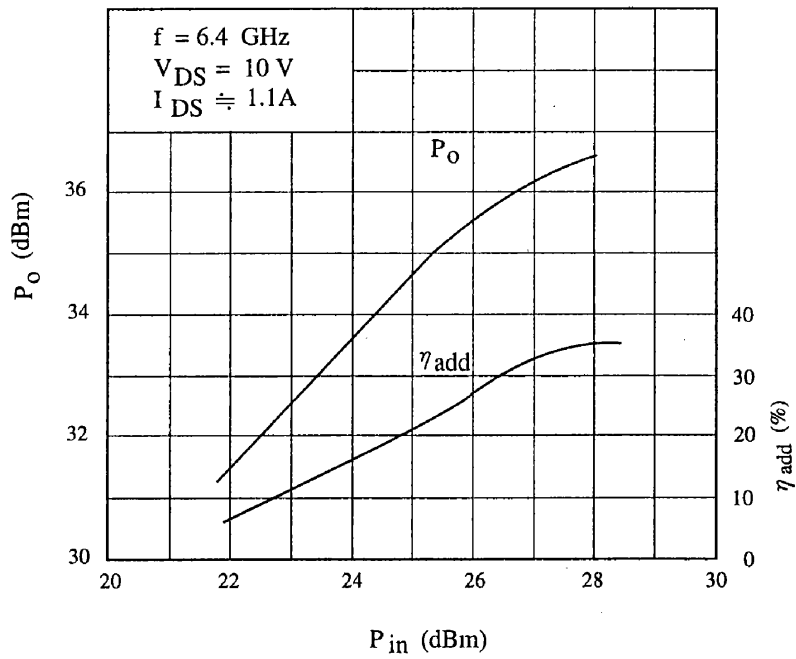

TIM5964-4A

POWER DISSIPATION VS. CASE TEMPERATURE

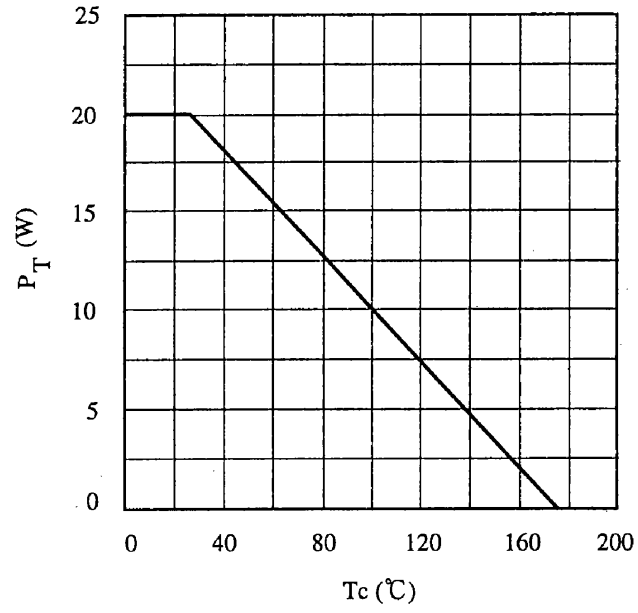

TIM5964-4A

TIM5964-4A S-PARAMETERS (MAGN.and ANGLES)

$V_{ds} = 10V, I_{ds} = 1.1A$

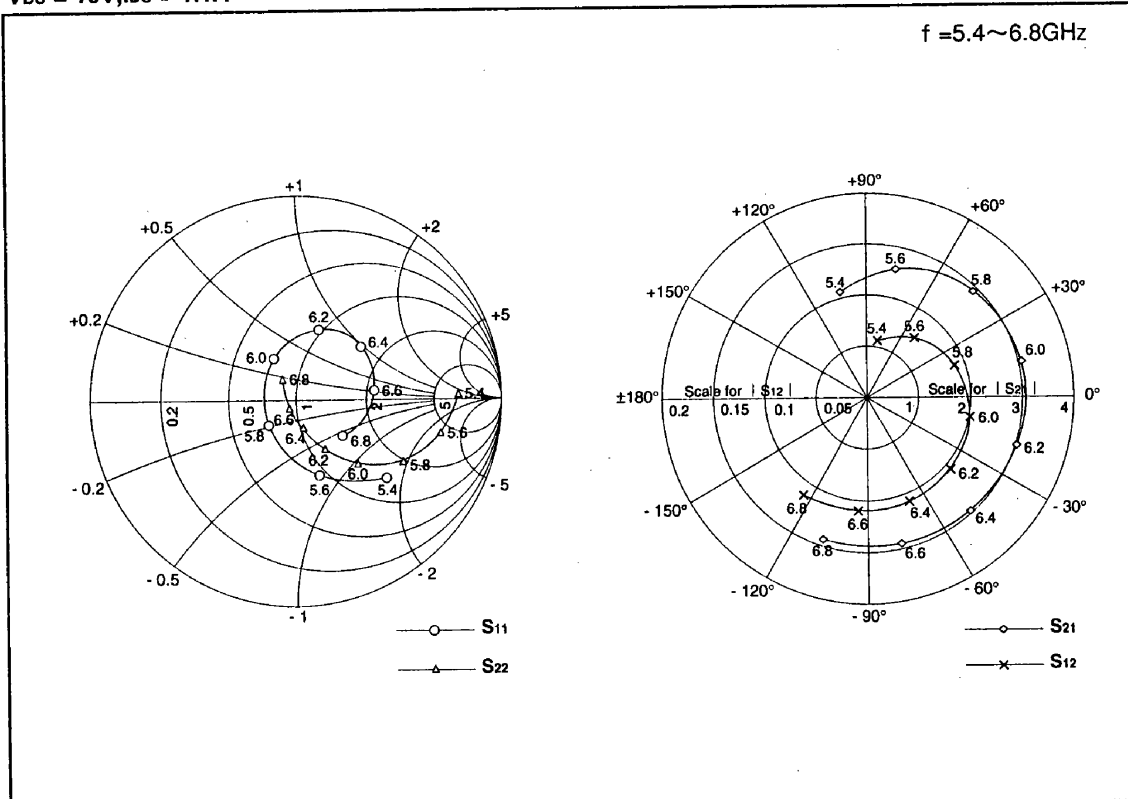

FREQUENCY (GHz)	S_{11}		S_{21}		S_{12}		S_{22}	
	MAG	ANG	MAG	ANG	MAG	ANG	MAG	ANG
5.4	0.58	-41	2.12	104	0.056	79	0.79	2
5.6	0.38	-73	2.56	77	0.074	51	0.72	-13
5.8	0.18	-138	2.91	45	0.090	20	0.60	-30
6.0	0.23	118	3.06	13	0.101	-11	0.43	-46
6.2	0.36	72	3.03	-18	0.106	-41	0.28	-60
6.4	0.41	39	2.95	-48	0.108	-68	0.14	-76
6.6	0.38	7	2.89	-77	0.110	-95	0.05	-129
6.8	0.28	-38	2.87	-108	0.113	-124	0.12	123