

LOW DROPOUT DUAL REGULATOR

DESCRIPTION

The SG29085/85A is a dual 8.2V/5V positive voltage regulator. One output is a high current (up to 1000 mA) regulator that can be turned on or off by a high impedance low current TTL compatible switch. The second or standby output remains on regardless. The on/off switch not only shuts off the high current output but actually puts the IC in a micropower mode making possible a low quiescent current. This unique characteristic coupled with an extremely low dropout, (.55V for output current of 10mA) makes the SG29085/85A well suited for power systems that require standby memory. The SG29085/85A includes other features which were originally designed for automotive applications. These include protection from reverse battery installations and double battery jumps. The high current regulator has overvoltage shutdown to protect both the internal circuitry and the load during line transients, such as load dump (60V). In addition, the high current regulator design also has built-in protection for short circuit and thermal overload. During these fault conditions of the primary regulator the standby regulator will continue to power its load.

The SG29085 is the 8.2 volt, $\pm 5\%$ version of a family of dual regulators with a standby output voltage of 5V. Other high current outputs of 5 and 12 volts are available. Also available is the SG28085A which offers an improved output voltage tolerance of $\pm 2\%$. They are available in the plastic TO-220 power package and are designed to function over the automotive ambient temperature range of -40°C to 85°C .

FEATURES

- 2% Internally Trimmed Output
- Two regulated outputs
- Output current in excess of 1000mA
- Low quiescent current standby regulator
- Input-output differential less than 0.6V at 0.5A
- Reverse battery protection
- 60V load dump protection
- -50V reverse transient protection
- Short circuit protection
- Internal thermal overload protection
- Available in plastic TO-220
- ON/OFF switch for high current output

TYPICAL APPLICATION CIRCUIT

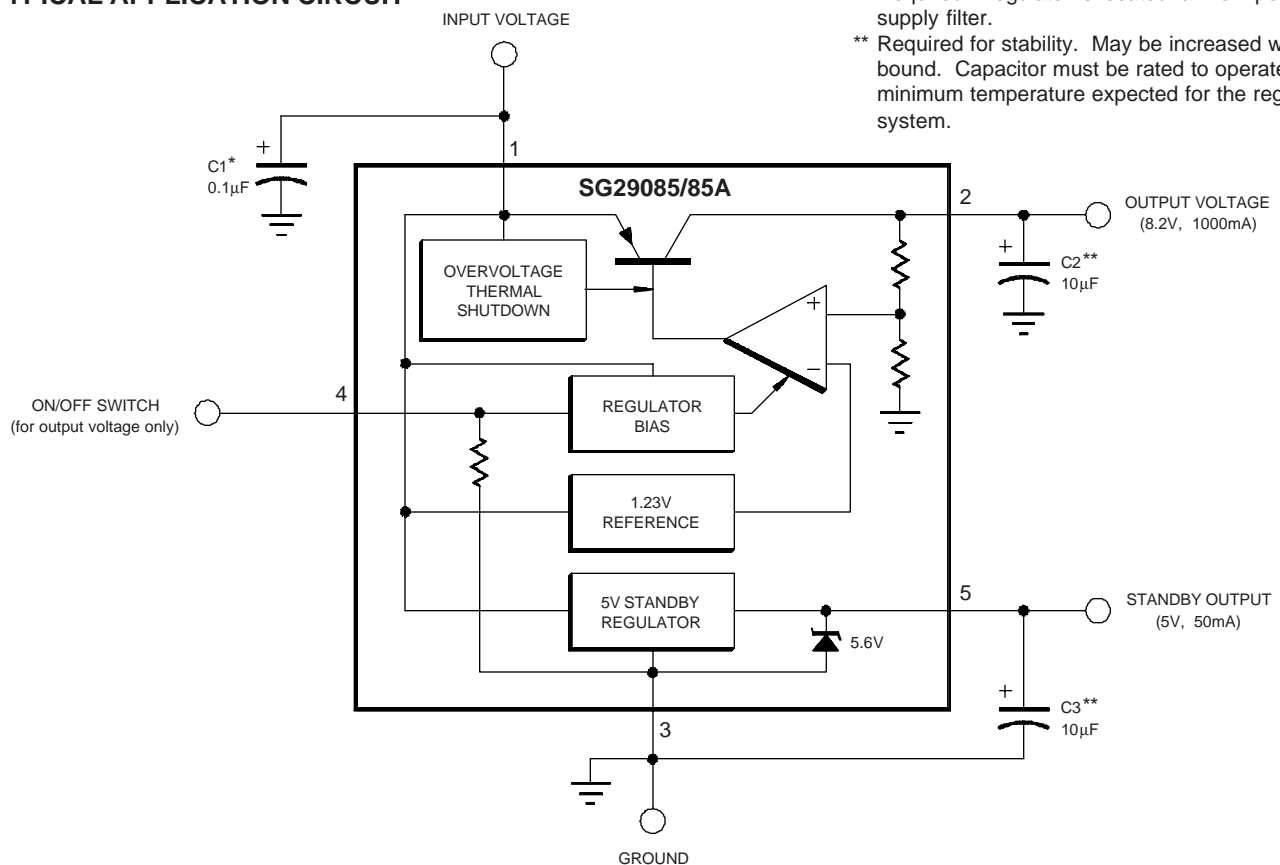

ABSOLUTE MAXIMUM RATINGS Note 1. Exceeding these values may destroy this part.

Input Voltage (V_{IN}) Operating	26V	Storage Temperature Range (T_{STG})	-65°C to 150°C
Input Voltage (V_{IN}) Overvoltage Transient	-15V to 60V	Operating Junction Temperature (T_J)	150°C
ON/OFF Switch	-0.3V to V_{IN}		

THERMAL DATA

P Package:

Thermal Resistance-Junction to Case, θ_{JT}	4.0°C/W*
Thermal Resistance-Junction to Ambient, θ_{JA}	55°C/W

* = θ_{JT} (Junction to Tab)

Note A. Junction Temperature Calculation: $T_J = T_A + (P_D \times \theta_{JA})$.

Note B. The above numbers for θ_{JC} are maximums for the limiting thermal resistance of the package in a standard mounting configuration. The θ_{JA} numbers are meant to be guidelines for the thermal performance of the device/pc-board system. All of the above assume no ambient airflow.

RECOMMENDED OPERATING CONDITIONS (Notes 2 & 3)

Input Voltage (V_{IN})	9V to 26V	Reverse Polarity D.C. Input Voltage (V_{IN}) ($V_O \geq -0.6V$, 16Ω load)	-15V max.
ON/OFF Threshold Voltage		Reverse Polarity Transient Input Voltage (V_{IN}) (1% duty cycle, $T \leq 100ms$, $V_O \geq -9V$, 16Ω load) ...	-50V max.
Low Level, V_{IL} (V_{OUT} is OFF)	0.8V max.	Output Capacitor with ESR of 10Ω max. (V_{OUT} to GND & V_{SB} to GND)	10μF min.
High Level, V_{IH} (V_{OUT} is ON)	2.0V min.	Operating Ambient Temperature Range - (T_A) SG29085/85A	-40°C to 85°C
Load Current V_{OUT} (with adequate heatsinking)	5 to 1000mA		
Maximum Line Transient (Load Dump) $V_{SB} \leq 6V$	60V max.		
Input Capacitor (V_{IN} to GND)	0.1 μF min.		

Note 2. Range over which the device is functional.

Note 3. During 60V load dump, V_{SB} shall not be less than 4.75V at $I_{OUT} = 10mA$.

ELECTRICAL CHARACTERISTICS (Unless otherwise specified, these specifications apply for the operating ambient temperature of $T_A = 25^\circ C$. $V_{IN} = 14V$, $I_O = 500mA$ for V_{OUT} and 10mA for V_{SB} and are for DC characteristics only. Low duty cycle pulse testing techniques are used which maintains junction and case temperatures equal to the ambient temperature.)

Parameter	Test Conditions	SG29085/85A			Units
		Min.	Typ.	Max.	
Voltage Output (V_{OUT}) Section					
Output Voltage (Note 4)	$9V \leq V_{IN} \leq 26V$, $I_O \leq 1000mA$, $-40^\circ C \leq T_A \leq 85^\circ C$				
	SG29085	7.8	8.2	8.6	V
	SG29085A	8.0	8.2	8.4	V
Line Regulation	$9V \leq V_{IN} \leq 16V$, $I_O = 5mA$		4	25	mV
	$9V \leq V_{IN} \leq 26V$, $I_O = 5mA$		10	50	mV
Load Regulation	$5mA \leq I_O \leq 1000mA$		10	50	mV
Output Impedance	$500mA_{DC}$ and $10mA_{RMS}$, 100Hz - 10kHz		200		mΩ
Quiescent Current	$I_O \leq 10mA$, No Load on Standby		2		mA
	$I_O = 500mA$, No Load on Standby		40	100	mA
	$I_O = 750mA$, No Load on Standby		90		mA
	$I_O = 220mA$, $I_{SB} = 10mA$, $V_{IN} = V_{OUT} - 200mV$		15	25	mA
Output Noise Voltage	10Hz - 100kHz		100		μV _{RMS}
Long Term Stability			20		mV/1000hr
Ripple Rejection	$F_O = 120Hz$		66		dB
Dropout Voltage	$I_O = 500mA$		0.45	0.6	V
	$I_O = 1000mA$	0.7		1.2	V
Current Limit		1.0	1.8	2.5	A
Maximum Operational Input Voltage	Double Battery	26.5	31		V
Maximum Line Transient	$V_O \leq 9V$	60	70		V
ON/OFF Switch (I_{IH})	$I_O = 10mA$, Pin 4 = 2.4V			10	μA
ON/OFF Switch (I_{IL})	$I_O = 10mA$, Pin 4 = 0.4V	-10			μA

ELECTRICAL CHARACTERISTICS (continued)

Parameter	Test Conditions	SG29085/85A			Units
		Min.	Typ.	Max.	
Standby Output (V_{SB}) Section					
Output Voltage (Note 4)	$6V \leq V_{IN} \leq 26V, I_o \leq 50mA, -40^\circ C \leq T_A \leq 85^\circ C$	4.75	5.0	5.25	V
Line Regulation	$6V \leq V_{IN} \leq 26V$		4	50	mV
Load Regulation	$1mA \leq I_o \leq 35mA$		10	25	mV
	$1mA \leq I_o \leq 50mA$		25	50	mV
Output Impedance	$1mA_{DC}$ and $1mA_{RMS}$, 100Hz - 10kHz		1		Ω
Quiescent Current	$I_o \leq 10mA, V_{OUT} OFF$		1.2	3	mA
Output Noise Voltage	10Hz - 100kHz		300		μV_{RMS}
Long Term Stability			20		mV/1000hr
Ripple Rejection	$F_o = 120Hz$		66		dB
Dropout Voltage	$I_o \leq 50mA$		0.55	0.7	V
Current Limit		50	100		mA
Maximum Operational Input Voltage	$4.75V \leq V_o \leq 6V$	60	70		V

Note 4. The temperature extremes are guaranteed but not 100% production tested.

TYPICAL CIRCUIT WAVEFORM

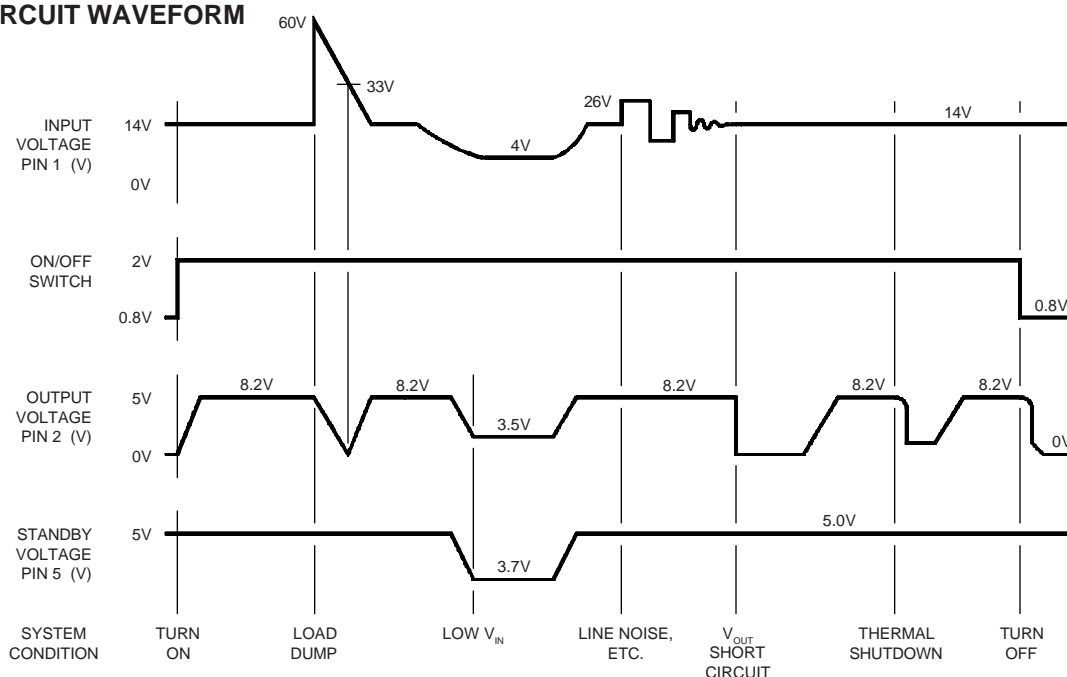

APPLICATION NOTES

The advantages of using a low-dropout regulator such as the SG29085/85A are the need for less "headroom" for full regulation, and the inherent reverse polarity protection provided by the PNP output device. A typical NPN regulator design requires an input to output differential of approximately two volts minimum. This is due to the $2V_{be} + V_{cesat}$ of the NPN Darlington used in the output, coupled with the voltage drop across the current limit resistor. In contrast, the "PNP Regulator" uses a single series pass transistor with its single V_{cesat} , thus the lower input to output voltage differential or dropout voltage.

In addition to a low dropout voltage, an important advantage of the SG29085/85A series is low quiescent current in the standby mode. When the high current or primary regulator is shut off, the

regulator enters a micropower mode. Here all but the most essential circuitry to power the standby output is deactivated. This allows the lowest possible quiescent current (typical around 1.2mA), a vital factor when used in a battery powered system.

In some applications the regulator output voltage is used not only as a power supply but also as a voltage reference for control systems. In such cases not just the temperature stability of the output is important but also the initial accuracy. The SG29085/85A fills this need as the internal bandgap reference is trimmed allowing a typical output voltage tolerance of $\pm 1\%$.

APPLICATION HINTS

EXTERNAL CAPACITORS

To stabilize the outputs and prevent oscillation (perhaps by many volts) external capacitors are required. The minimum recommended value for the output capacitors is 10 μ F, although the actual size and type will likely vary according to the particular application, e.g., operating temperature range and load. Another consideration is the effective series resistance (ESR) of the capacitor. Capacitor ESR will vary by manufacturer. Consequently, some evaluation may be required to determine the minimum value of the output capacitors. Generally worst case occurs at the maximum load and minimum ambient temperature.

The size of the output capacitor can be increased to any value above the minimum. One possible advantage of this would be to maintain the output voltage during brief periods of negative input transients

The output capacitors chosen should be rated for the full range of ambient temperature over which the circuit will be exposed and expected to operate. For example, many aluminum type electrolytic capacitors will freeze at -30°C. The effective capacitance is reduced to zero in such a situation. Capacitors rated for -40°C operation must be used in order to maintain regulator stability at that temperature. Tantalum capacitors satisfy this requirement.

STANDBY OUTPUT

The SG29085/85A differs from most fixed voltage regulators in that it is equipped with two regulator outputs instead of one. The additional output is intended for use in systems requiring standby memory circuits. While the high current regulator output can be controlled with the ON/OFF pin described below, the standby remains on under all conditions as long as sufficient input voltage is applied to the IC. Thus, memory and other circuits powered by this output remain unaffected by positive line transients, thermal shutdown, etc.

The standby regulator circuit is designed so that the quiescent current to the IC is very low (<1.5mA) when the other regulator output is off.

If the standby output is not required it can be disabled. This is accomplished by connecting a resistor from the standby output to the supply voltage, thereby also eliminating the requirement for a more expensive output capacitor to prevent unwanted oscillations. The resistor value depends upon the minimum input voltage expected for a given system.

Since the standby output is shunted with an internal 5.6V zener,

the current through the external resistor should be sufficient to bias internal resistors up to this point. Approximately 60 μ A will suffice, resulting in a 10k external resistor for most applications (Figure 1).

HIGH CURRENT OUTPUT

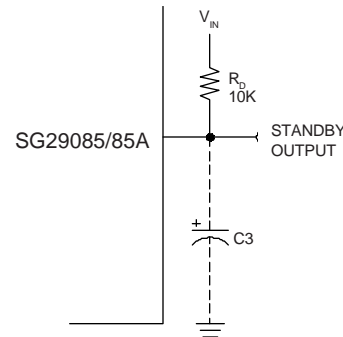

FIGURE 1. Disabling Standby Output to Eliminate C3

The high current regulated output features fault protection against overvoltage as well as a thermal shutdown feature. If the input voltage rises above 33V (load dump), the high current output shuts down automatically. The internal circuitry is thus protected and the IC is able to survive higher voltage transients than might otherwise be expected. The thermal shutdown of the high current output effectively guards against overheating of the die since this section of the IC is the principle source of power dissipation on the chip.

ON/OFF SWITCH

The ON/OFF pin is a high impedance low current switch that controls the main output voltage (pin 2). This is directly compatible with all 5 volt logic families. For use with open collector logic outputs, a 100Kresistor from this pin to a 5V supply, such as Pin 5, is required.

CONNECTION DIAGRAM & ORDERING INFORMATION (See Note Below)

Package	Part No.	Ambient Temperature Range	Connection Diagram
5-PIN TO-220 PLASTIC P - PACKAGE	SG29085P SG29085AP	-40°C to 85°C -40°C to 85°C	

Note: 1. All packages are viewed from the top.