

DATA IMAGE CORPORATION

LCD Module Specification

ITEM NO.: SG243200CNCWA-T1

Table of Contents

| | |
|---|----|
| 1. COVER & CONTENTS | 1 |
| 2. RECORD OF REVISION | 2 |
| 3. GENERAL SPECIFICATIONS | 3 |
| 4. ABSOLUTE MAXIMUM RATINGS | 4 |
| 5. ELECTRICAL CHARACTERISTICS | 6 |
| 6. ELECTRO-OPTICAL CHARACTERISTIC | 6 |
| 7. TIMING CHARACTERISTICS | 9 |
| 8. PIN CONNECTIONS | 13 |
| 9. POWER SUPPLY | 13 |
| 10. BLOCK DIAGRAM | 14 |
| 11. TOUCH PANEL CHARACTERISTICS | 15 |
| 12. QUALITY ASSURANCE | 17 |
| 13. LOT NUMBERING SYSTEM | 21 |
| 14. LCM NUMBERING SYSTEM | 21 |
| 15. PRECAUTIONS IN USE LCM | 22 |
| 16. OUTLINE DRAWING | 23 |
| 17. PACKAGE INFORMATION | 24 |

| | | | |
|-----------|--------------|-------------|--------------|
| R&D Dept. | Q.C. Dept. | Eng. Dept. | Prod. Dept. |
| | | | |
| Version: | Issued Date: | Sheet Code: | Total Pages: |
| | 2002/8/29 | | 24 |

2. RECORD OF REVISION

| Rev | Date | Item | Page | Comment |
|-----|------|------|------|---------|
| | | | | |

3. GENERAL SPECIFICATION

Display Format : 240x3(R.G.B) (W) × 320 (H) dots
Dot Size : 0.067 (W) × 0.211 (H) mm
Dot Pitch : 0.076 (W) × 0.23 (H) mm
View Area : 57.8 (W) × 76.58 (H) mm
Outline Dimensions : 71.7 (W) × 90.8 (H) × 7.4 (T) mm Max.
Weight : g max.

LCD Type : STN Color STN Yellow FSTN TN

Polarizer mode : Reflective Transflective

Transmissive Negative

Display dots Black Others

View Angle : 6 O'clock 12 O'clock Others

Backlight : LED EL CCFL

Backlight Color : Yellow green Amber Blue Green

White Others

Duty Ratio 1/323

Temperature Range : Normal Wide Temperature
Operating 0 to 50°C Operating -20 to 70°C
Storage -20 to 60°C Storage -30 to 80°C

4. ABSOLUTE MAXIMUM RATINGS

4.1 ELECTRICAL ABSOLUTE MAXIMUM RATINGS

$V_{SS}=0V$, $T_a = 25^{\circ}C$

| Item | Symbol | Min. | Max. | Unit |
|-----------------------------|-----------------|------|--------------|-------------|
| Supply Voltage (Logic) | $V_{DD}-V_{SS}$ | 0 | 7.0 | V |
| Supply Voltage (LCD Driver) | $V_{EE}-V_{SS}$ | 0 | 42 | V |
| Input Voltage | V_i | -0.3 | $V_{DD}+0.3$ | V |
| Input Current | I_i | 0 | 1 | A |
| Operating Temperature | T_{OP} | 0 | 50 | $^{\circ}C$ |
| Storage Temperature | T_{STG} | -20 | 60 | $^{\circ}C$ |

4.2 ENVIRONMENTAL ABSOLUTE MAXIMUM RATINGS

| Item | Operating | | Storage | | Comment |
|---------------|----------------|-------|----------------|--------|----------------------------|
| | (Min.) | Max.) | (Min.) | (Max.) | |
| Ambient Temp | 0 | 50 | -20 | 60 | Note(2),(3) |
| Humidity | Note (1) | | Note(1) | | Without Condensation |
| Vibration | -- | -- | -- | -- | Depends on housing design. |
| Shock | -- | -- | -- | -- | Depends on housing design. |
| Corrosive Gas | Not Acceptable | | Not Acceptable | | |

Note(1) $T_a \leq 40^{\circ}C$: 85%RH Max.

$T_a > 40^{\circ}C$: Absolute humidity must be lower than the humidity of 85%RH at $40^{\circ}C$.

Note(2) T_a at $-20^{\circ}C$ for 48 hrs, at $60^{\circ}C$ for 120 hrs.

Note(3) Background color changes slightly depending on ambient temperature. This phenomenon is reversible.

Note(4) When LCM will be operated less than $5^{\circ}C$. The life time of CFL will be reduced need to make sure of value of IL and characteristics of inverter, also the response time less than $5^{\circ}C$ will be slower.

4.3 Electronic Static Discharge maximum rating

ESD test method : IEC1000-4-2

| Item | Description |
|---------------------|--|
| Testing environment | Ambient temperature :15°C to 35 °C Humidity: 30% to 60 % LCM (E.U.T) : Power up |
| Testing equipment | Manufacture: Noise Ken , Model No. ESD-100L |
| Testing condition | See drawing 1 |
| Direct discharge | 0 to ± 6 KV Discharge point, see drawing 2 |
| Indirect discharge | 0 to ± 12KV Discharge point, see drawing 1 |
| Pass condition | No malfunction of unit. Temporary malfunction of unit which can be recovered by system reset |
| Fail condition | Non. Recoverable malfunction of LCM or system |

FIG 1 ESD TESTING EQUIPMENT

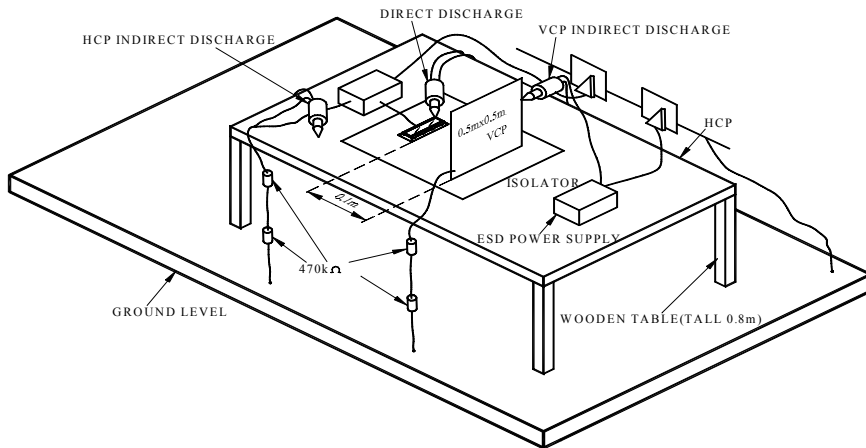

(1)

DIRECT CONTACT DISCHARGE CONTACT POINT : A.B.C.D

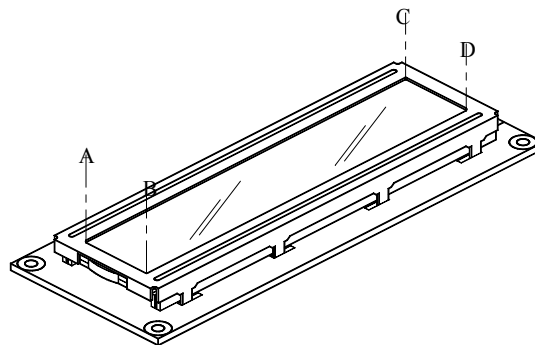

(2)

5. ELECTRICAL CHARACTERISTICS

Ta=25°C

| Item | Symbol | Condition | Min. | Typ. | Max. | Unit |
|---------------------------------------|----------------------------------|---|--------------------|------|--------------------|------|
| Supply Voltage (Logic) | V _{DD} -V _{SS} | | 2.7 | 3.3 | 5.5 | V |
| Contrast Adjustment Voltage (Note 1) | V _{EE} -V _{SS} | 0°C | 29.1 | 30.1 | 31.1 | V |
| | | 25°C | 27.5 | 28.5 | 29.5 | |
| | | 40°C | 26.8 | 27.8 | 28.8 | |
| Input Voltage for Logic Circuits | V _{IH} | | 0.8V _{DD} | -- | V _{DD} | V |
| | V _{IL} | | 0 | -- | 0.2V _{DD} | |
| Power Supply Current(Note 2,3) | I _{DD} | V _{DD} -V _{SS} =3.3V | -- | 0.5 | -- | mA |
| | I _{EE} | V _{EE} -V _{SS} =28.5V | -- | 1.4 | -- | |
| Frame Frequency (Note 4) | fFLM | 25°C | 60 | 70 | 80 | Hz |

Note 1: fFLM =70Hz,Ta=25°C, Display pattern :Checker pattern.

Note 2: Rush Current of power ON:200mA(PK)x100μs.

Note 3: Need to make sure of flickering and rippling of display when setting the Frame frequency and msignal frequency in your set.

6. ELECTRO-OPTICAL CHARACTERISTICS

| ITEM | | Symbol | Condition | Min. | Typ. | Max. | Unit | Ref. |
|-----------------------------|-------|--------|---------------|------|------|------|------|---------------------------------|
| View Angle | | ∅2- ∅1 | θ = 0°, K≥2.0 | -- | 40 | -- | deg | Note (1), Note (2) |
| Contrast ratio | | K | θ = 0°, ∅=0° | 30 | 45 | -- | | Note(3), Note(5), Note(6) |
| Response time (rise + fall) | tr | | θ = 0°, ∅=0° | -- | 250 | -- | ms | Note (4) |
| | tf | | | -- | 150 | -- | ms | |
| Color tone (Primary Color) | Red | X | θ = 0°, ∅=0° | 0.48 | 0.53 | 0.58 | | Note(7) |
| | | Y | | 0.26 | 0.31 | 0.36 | | |
| | Green | X | | 0.25 | 0.30 | 0.35 | | |
| | | Y | | 0.50 | 0.55 | 0.60 | | |
| | Blue | X | | 0.11 | 0.16 | 0.21 | | |
| | | Y | | 0.12 | 0.17 | 0.22 | | |
| | White | X | | 0.25 | 0.30 | 0.35 | | |
| | | Y | | 0.30 | 0.35 | 0.40 | | |

Note 1. Definition of θ and ϕ

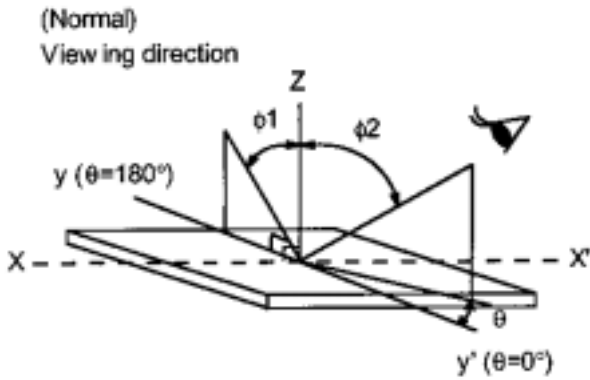

Note 3. Definition of contrast "k"

$$K = \frac{\text{Brightness of selected area (B1)}}{\text{Brightness of non-selected area (B2)}}$$

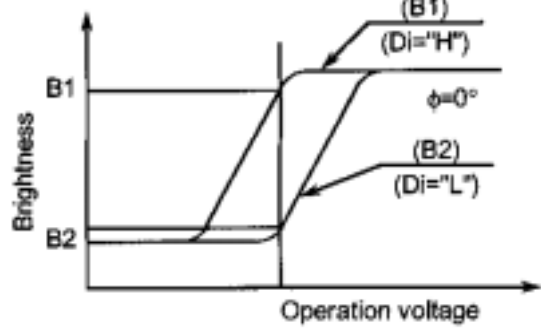

Note 2. Definition of viewing angle $\phi 1$ and $\phi 2$

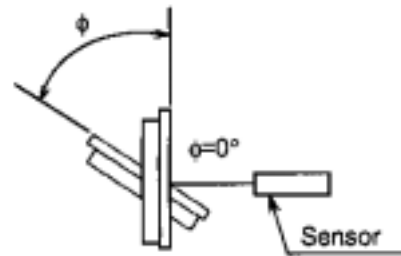
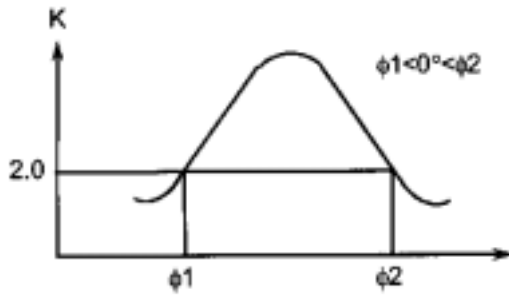

Contrast ratio K vs viewing angle ϕ

Sensor: BM-7
Aperture : 1°
Distance : 0.4m

Note 4. Definition of optical response time

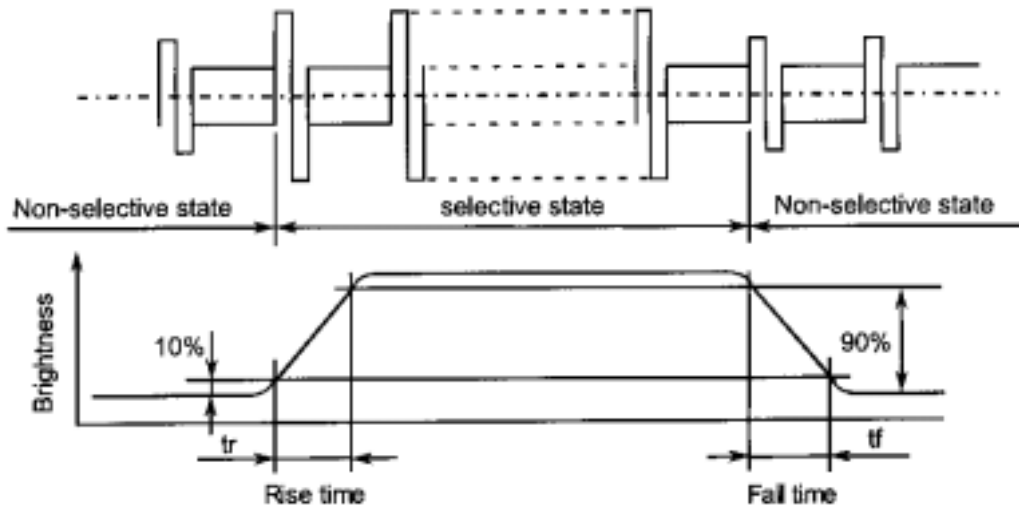

6.1 OPTICAL CHARACTERISTICS OF CCFL BACKLIGHT

Ta=25°C

| ITEM | Symbol | Min. | Typ. | Max. | Unit |
|------------------------------|----------------|-----------------|------|------|------|
| Lamp Voltage | VL | 250 | 280 | 310 | Vrms |
| Frequency | fL | 50 | -- | -- | KHz |
| Lamp Current (1Lamp)(Note 7) | IL | 0.5 (Note 9) | 1.25 | 2.0 | mA |
| Starting discharge Voltage | VS (Note 2) | 595 | -- | -- | Vrms |

Note 1: Please design your lamp driving circuit (inverter) according to the above specifications.

Note 2: Starting discharge voltage is increased when LCM is operating at lower temperature. Please check the characteristics of your inverter before applying to your set.

Note 3: Average life time of CFL will be decreased when LCM is operating at lower temperature.

Note 4: Under lower driving frequency of an inverter, a certain backlight system (CFL & CFL reflection sheet) may generate a sound noise. Before designing the inverter, please consider the driving frequency and the noise.

Note 5: When IL is over 3.0mA, it may cause uneven contrast near CFL location, due to heat dispersion from CFL.

Note 6: Absolute maximum rating voltage of CFL cable for this module is as follows.

VCF side: 2Kv

VSS side: 300V

This inverter design shall not exceed the rated voltage.

Note 7: We suggest that the lamp current can not be lower than the standard of CAS set, or it will cause low brightness.

Note 8: The brightness of the CFL in this LCM may deteriorate after the long-hour use under ICFL=1.25mA. However, it will recover when the CFL is lighted at ICFL=2.0mA min. 5 minutes or more.

Note 9: Except at starting up.

6.2 Recommend CCFL inverter:

TDK L10L operation voltage +12V , 300mA

TDK L10A operation voltage +5V , 600mA

7. TIMING CHARACTERISTIC

(1) INTERFACE TIMING DIAGRAM

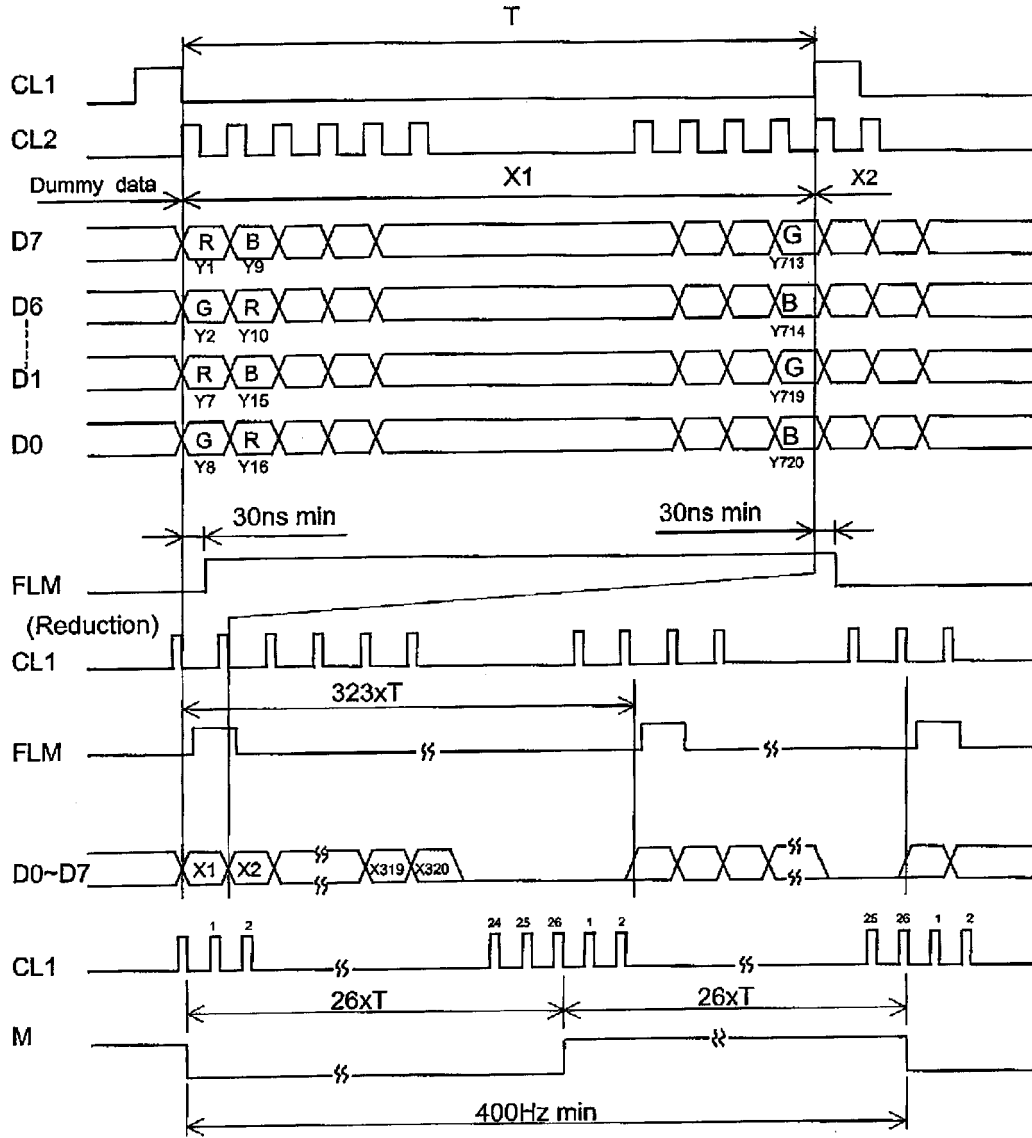

Note 1. M signal should be kept 400Hz min. and 50% duty.

(2) INTERFACE TIMING DIAGRAM

(VSS=0V,VDD=2.7-5.5V, ta=0 to 50°C)

| Item | Symbol | Min. | Typ. | Max. | Units |
|------------------------|--------------------------------|------|------|------|-------|
| CL1 pulse width H | t _{WHCL1} | 50 | -- | -- | ns |
| CL1 pulse width L | t _{WHCL1} | 370 | -- | -- | ns |
| Clock cycle time | t _{CYC} | 100 | -- | -- | ns |
| CL2 pulse width | t _{WCL2} | 37 | -- | -- | ns |
| Clock set up time | t _{SCL1} | 100 | -- | -- | ns |
| Clock hold time | t _{HCL1} | 100 | -- | -- | ns |
| Clock rise fall time | t _r ,t _f | -- | -- | 30 | ns |
| Data set up time | t _{DSU} | 35 | -- | -- | ns |
| Data hold time | t _{DH} | 35 | -- | -- | ns |
| FLM set up time | t _{FS} | 100 | -- | -- | ns |
| FLM hold time | t _{FH} | 30 | -- | -- | ns |
| M delay time | t _M | -- | -- | 300 | ns |

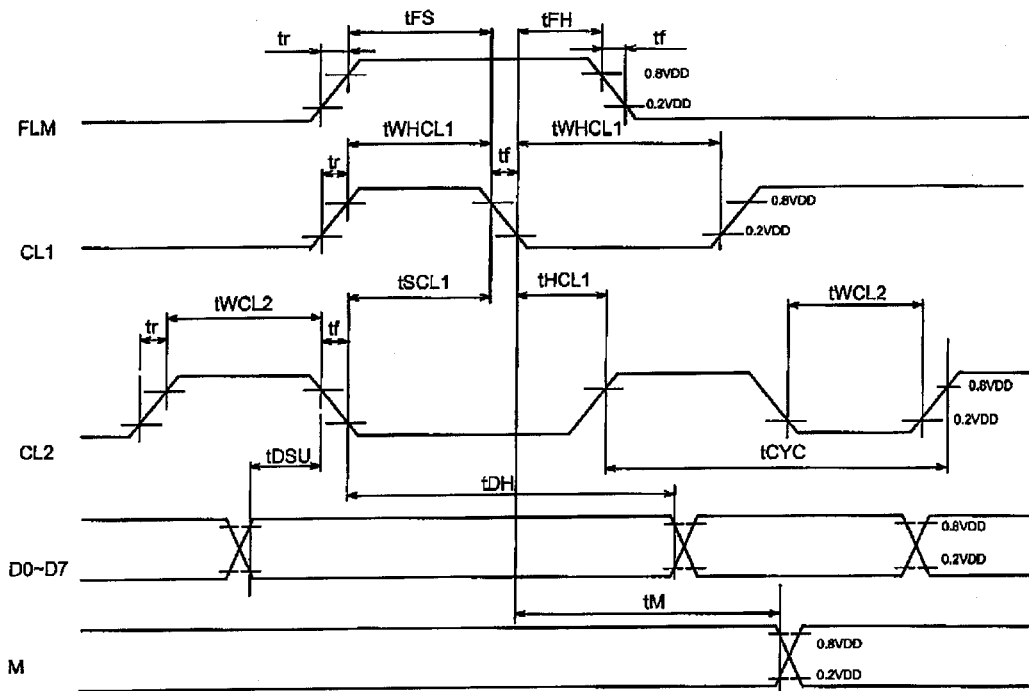

(3) POWER ON/OFF SEQUENCE

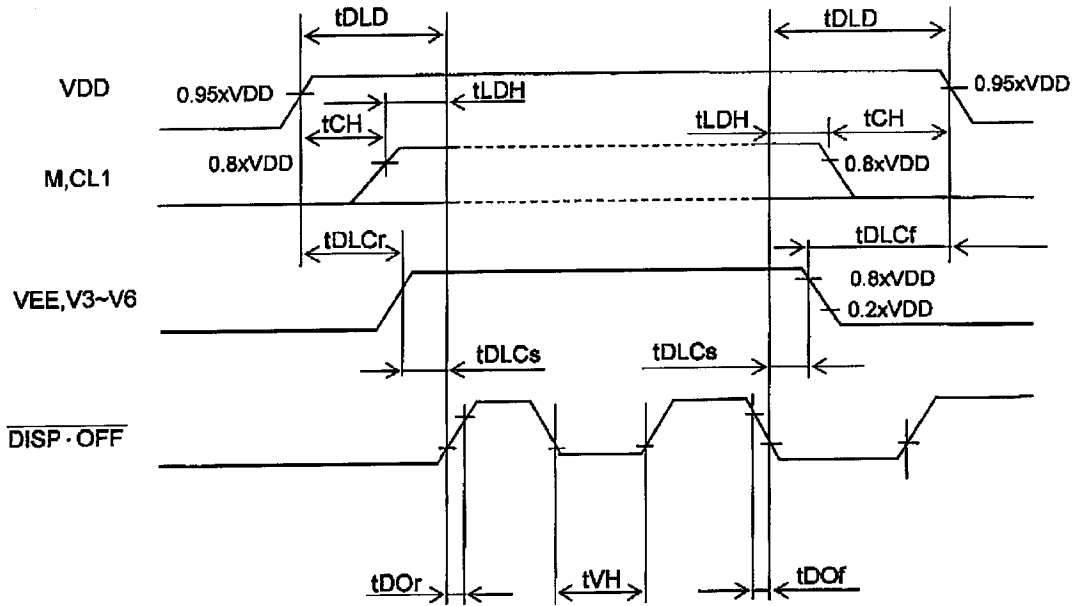

| Symbol | Min. | Max. | Units | Comment |
|--------|------|------|-------|----------|
| tDLD | 200 | -- | ms | (Note 1) |
| tCH | 0 | -- | ms | |
| tLDH | 0 | -- | ms | |
| tDOr | -- | 100 | ms | (Note 2) |
| tDOF | -- | 100 | ms | |
| tDLCr | 20 | -- | ms | |
| tDLCf | 0 | -- | ms | |
| tDLCs | 20 | -- | ms | |
| tVH | 200 | -- | ms | |

(Note 1) Please keep the specified sequence because wrong sequence may cause Permanent damage to the LCD panel .

(Note 2) We recommends you to use $\overline{\text{DISP}}\cdot\overline{\text{OFF}}$ function.

Display quality may deteriorate if you don't use $\overline{\text{DISP}}\cdot\overline{\text{OFF}}$ function.

(4) INPUT DATA ALLOCATION TABLE

| Data Signal | D | D | D | D | D | D | D | D | D | D | D | D | ----- | D | D | D | D | D |
|-------------|-------|-------|-------|-------|-------|-------|-------|-------|-------|-------|-------|-------|-------|-------|-------|-------|-------|-------|
| | 7 | 6 | 5 | 4 | 3 | 2 | 1 | 0 | 7 | 6 | 5 | 4 | ----- | 4 | 3 | 2 | 1 | 0 |
| X \ Y | 1 | 2 | 3 | 4 | 5 | 6 | 7 | 8 | 9 | 10 | 11 | 12 | ----- | 7 | 7 | 7 | 7 | 7 |
| 1 | R | G | B | R | G | B | R | G | B | R | G | B | ----- | G | B | R | G | B |
| 2 | R | G | B | R | G | B | R | G | B | R | G | B | ----- | G | B | R | G | B |
| 3 | R | G | B | R | G | B | R | G | B | R | G | B | ----- | G | B | R | G | B |
| 4 | R | G | B | R | G | B | R | G | B | R | G | B | ----- | G | B | R | G | B |
| 5 | R | G | B | R | G | B | R | G | B | R | G | B | ----- | G | B | R | G | B |
| 6 | R | G | B | R | G | B | R | G | B | R | G | B | ----- | G | B | R | G | B |
| 7 | R | G | B | R | G | B | R | G | B | R | G | B | ----- | G | B | R | G | B |
| | | | | | | | | | | | | | ----- | | | | | |
| 314 | R | G | B | R | G | B | R | G | B | R | G | B | ----- | G | B | R | G | B |
| 315 | R | G | B | R | G | B | R | G | B | R | G | B | ----- | G | B | R | G | B |
| 316 | R | G | B | R | G | B | R | G | B | R | G | B | ----- | G | B | R | G | B |
| 317 | R | G | B | R | G | B | R | G | B | R | G | B | ----- | G | B | R | G | B |
| 318 | R | G | B | R | G | B | R | G | B | R | G | B | ----- | G | B | R | G | B |
| 319 | R | G | B | R | G | B | R | G | B | R | G | B | ----- | G | B | R | G | B |
| 320 | R | G | B | R | G | B | R | G | B | R | G | B | ----- | G | B | R | G | B |

R:RED
G:GREEN
B:BLUE

8. PIN CONNECTIONS

| No. | Symbol | Function |
|-----|-----------|--|
| 1 | VSS | Power Supply (OV, Ground) |
| 2~9 | DB0~DB7 | Display data |
| 10 | VDD | Power Supply for logic |
| 11 | VEE | Power Supply for LCD |
| 12 | V6 | Bias Voltage for non-select (common driver) |
| 13 | V3 | Bias Voltage for non-select (segment driver) |
| 14 | V4 | Bias Voltage for non-select (segment driver) |
| 15 | V5 | Bias Voltage for non-select (common driver) |
| 16 | /DISP_OFF | H: Display ON L: Display OFF |
| 17 | CL2(CP) | Data Shift Clock |
| 18 | M | AC Signal input for LCD drive wave form |
| 19 | CL1(LP) | Data latch Clock |
| 20 | FLM | First Line Marker |

CCFL CN2 JST :housing :BHSR-02VS-1(Suitable Connector :JST SMO2(4.0)B-BHSS-1)
Contact pin : SBH-001T-P0.5

| No. | Symbol | Function |
|-----|--------|-----------------------|
| 1 | VSS | GND for CCFL |
| 2 | VCFL | Power Supply for CCFL |

CN3 Touch Screen Flat Cable(1.0mm pitch)

| No. | Symbol | Function |
|-----|--------|------------------------|
| 1 | X2 | Signal for touch panel |
| 2 | Y2 | |
| 3 | X1 | |
| 4 | Y1 | |

9. POWER SUPPLY

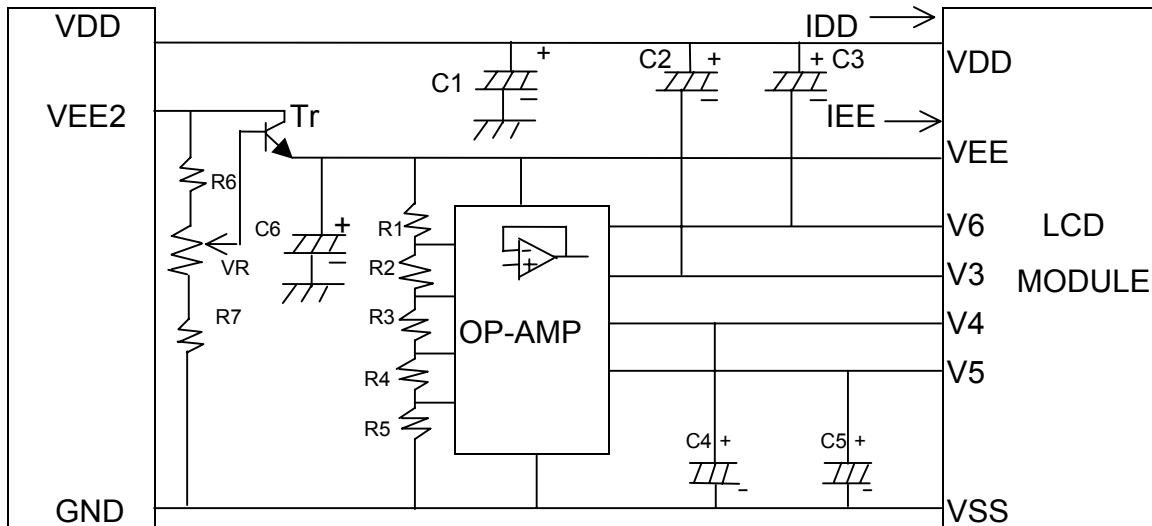

Tr: 2SD1368 R1=R2=R4=R5=20KΩ;R3=300KΩ;R6=10KΩ;R7=200KΩ;VR=50KΩ
C1= C2=C3=C4=C5=C6=3.3uF~4.7uF ;VEE2=32V

10. BLOCK DIAGRAM

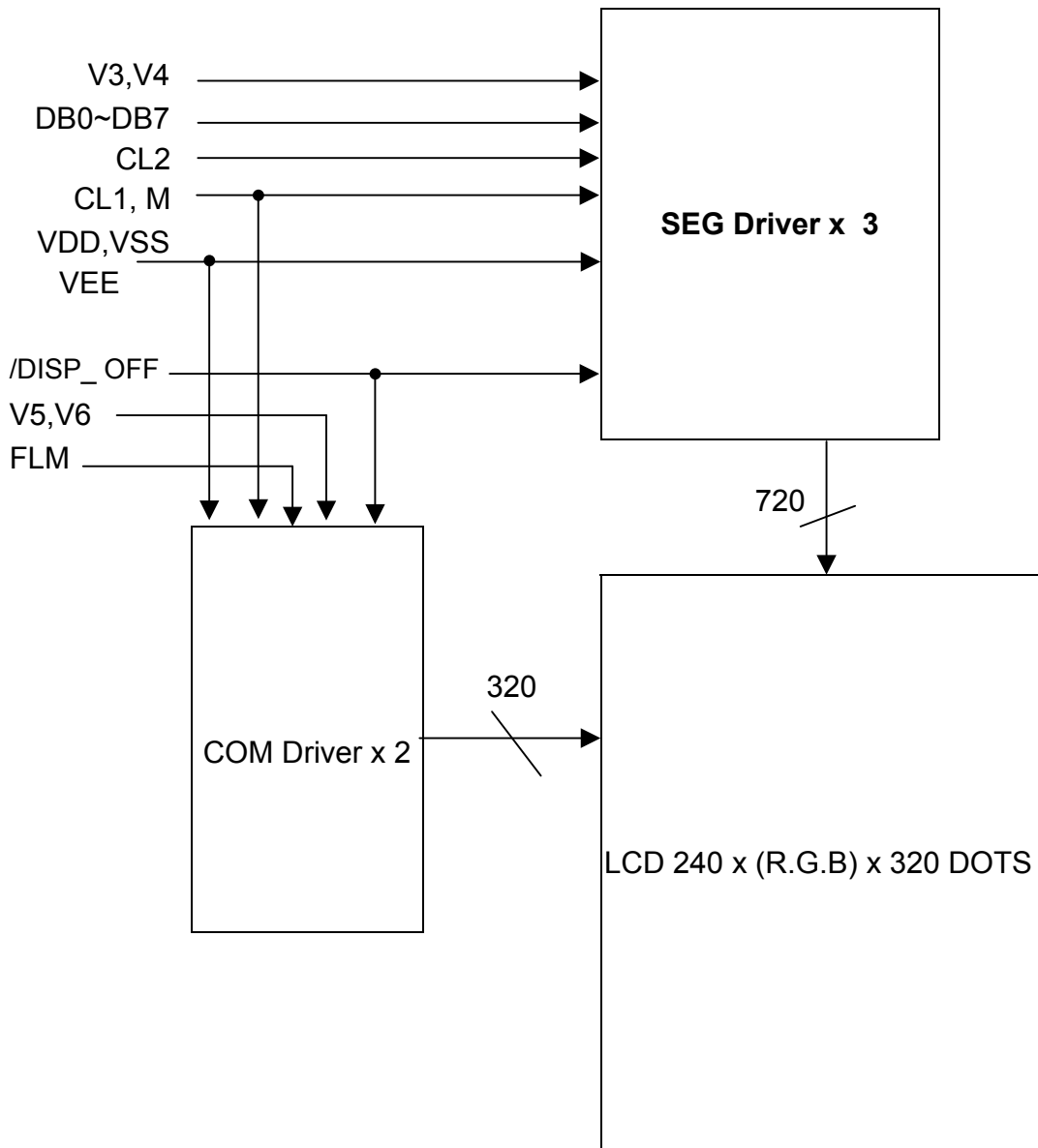

11. TOUCH PANEL CHARACTERISTICS

1.Scope

This specification is applied to DATA IMAGE Display Devices Product/ SG243200

2. Features

- Type : Analog Resistive Type Touch Panel
- Input Mode : Pen or Finger
- Structure: PET-----Non Glare ITO Film, 175μm
 Clear ITO Film, 175μm
 Glass-----ITO Glass, 0.7mm/1.1mm/1.8mm
 Tape Gasket----60μm
 Dot pitch-----1.0 mm(Optional)
- Connector : FPC

3. General Specification

| Item | Specification | Unit |
|-----------------|--|------|
| ITO Glass | 1.1±0.1(T) | mm |
| FPC (ITO Film) | 175±15(ITO Film) | μm |
| Connector | FPC,4-pin connector (L23.3*W5.5),Pitch=1.0 | mm |
| Total Thickness | 87.3±0.3(W)*69.3±0.3(H)*0.95±0.15(T) | mm |

4. RATING

- 4.1 The maximum voltage: DC 7Volts
- 4.2 Usable Temperature Range From: -20°C to 60 °C(20~90%)
- 4.3 Storage Temperature Range From: -40°C to 80 °C(20~90%)

5. Electrical Specification

- 5.1 Resistance between leads: FILM(X axis) GLASS (Y axis):200~900Ω
- 5.2 Linearity : X axis ±1.5%↓,Y axis ±1.5%↓
- 5.3 Insulation resistance: 20MΩ↑ @DC 25V
- 5.4 Chattering Time : 10msec @100KΩ↓ Pull -UP

6. Mechanical Specification

- 6.1 Input Method pen or Finger
- 6.2 Operating Force: 80g↓ With R8.0 HS40° Silicon Rubber
 80g↓ With R0.8 Polyacetal pen
- 6.3 Surface Hardness: 2H (Pencil Test) ,Hard Coated PET
- 6.4 Light Transmission: 75%↑ (Non Glare Type),80%↑ (Clear Type)
 (@550nm, Spectro Photometer Hitachi U3300)

7. Durability

- 7.1 Durability against Writing Characters
 After writing 200,000 characters in the same area (20mm*20mm),
 Force : 250g , Speed: 1,000 characters/hour
 - Resistance Between Leads : FILM (X axis) GLASS (Y axis)
 - Linearity : X axis ±1.0%↓, Y axis ±1.0%↓
 - Insulation Resistance: 20 M Ω↑ @DC 25V
- 7.2 Punching Life
 After Punching 1,200,000 Times with the R8.0 silicon rubber
 Force : 250g, Speed:2/sec
 - Resistance Between Leads : FILM (X axis) GLASS (Y axis)
 - Linearity : X axis ±1.0%↓, Y axis ±1.0%↓

- Insulation Resistance: 20 M Ω \uparrow @DC 25V
- 7.3 Impact Resistance:
No damage when ϕ 9mm steel ball is dropped on the surface from 30cm height at 1 time.
- 7.4 Flexible Pattern Heat Seal Peeling Strength :1.5N/cm (peeling upward by 90deg. Speed:50mm/min)
- 7.5 Flexible Pattern Bending Resistance Bending: 3 times or more by bending radius R1.0mm.
- 7.6 Flexible Pattern insert/pull out Resistance 5 times at least.
The requirements in 5.1 shall be satisfied.
- 7.7 Vibration Resistance (In operation)
No faulty operation when sweep vibration of 0.2G 10~55Hz (1min.) is given for 30min. each in the directions of X,Y,Z.
(Not in operation)
The requirements in 6.2 and 5.1~5.4 shall be satisfied after sweep vibration of 2g 10~55Hz (1min.) is given for 30min. each in the directions of X,Y,Z.
- 7.8 Package Drop
No damage to the product.(1 corner edge, 2 ridges, 4 surfaces, drop from 50 cm height:65cm for the bottom)

8. Reliability

- 8.1 High Temperature Test
After putting Panels at 80°C for 120 hours, then leaving for 24 hours at room temperature.
 - Resistance Between Leads : FILM (X axis) GLASS(Y axis)
 - Linearity : X axis \pm 1.5% \downarrow , Y axis \pm 1.5% \downarrow
 - Insulation Resistance: 20 M Ω \uparrow @DC 25V
 - Operating Fore : 80g \downarrow With R8.0 HS40° Silicon Rubber
80g \downarrow With R0.8 Polyacetal pen
- 8.2 Low Temperature Test
 - After putting panels at -40°C for 120 hours, then leaving for 24 hours at room temperature.
 - Resistance Between Leads : FILM (X axis) GLASS(Y axis)
 - Linearity : X axis \pm 1.5% \downarrow , Y axis \pm 1.5% \downarrow
 - Insulation Resistance: 20 M Ω \uparrow @DC 25V
 - Operating Fore : 80g \downarrow With R8.0 HS40° Silicon Rubber
80g \downarrow With R0.8 Polyacetal pen
- 8.3 Temperature and Humidity Test: After putting panels at 60°C, 90%RH for 120 hours, then leaving for 24 hours at room temperature
 - Resistance Between Leads : FILM (X axis) GLASS(Y axis)
 - Linearity : X axis \pm 1.5% \downarrow , Y axis \pm 1.5% \downarrow
 - Insulation Resistance: 20 M Ω \uparrow @DC 25V
 - Operating Fore: 80g \downarrow With R8.0 HS40° Silicon Rubber
80g \downarrow With R0.8 Polyacetal pen
- 8.4 Repetition of High and Low Temperature
After putting panels at the condition of -40°C for 30minutes, and then 80°C for 30 minutes and this process is repeated by 10 cycles, then leaving for 24 hours at room temperature.
 - Resistance Between Leads : FILM (X axis) GLASS(Y axis)
 - Linearity : X axis \pm 1.5% \downarrow , Y axis \pm 1.5% \downarrow
 - Insulation Resistance: 20 M Ω \uparrow @DC 25V
 - Operating Fore : 80g \downarrow With R8.0 HS40° Silicon Rubber
80g \downarrow With R0.8 Polyacetal pen

12. QUALITY ASSURANCE

12.1 Test Condition

12.1.1 Temperature and Humidity(Ambient Temperature)

Temperature : $25 \pm 5^{\circ}\text{C}$

Humidity : $60 \pm 5\%$

12.1.2 Operation

Unless specified otherwise, test will be conducted under function state.

12.1.3 Container

Unless specified otherwise, vibration test will be conducted to the product itself without putting it in a container.

12.1.4 Test Frequency

In case of related to deterioration such as shock test. It will be conducted only once.

12.1.5 Test Method

| No. | Parameter | Conditions | Regulations |
|-----|--|--|-------------|
| 1 | High Temperature Operating | $50 \pm 2^{\circ}\text{C}$ | Note 3 |
| 2 | Low Temperature Operating | $0 \pm 2^{\circ}\text{C}$ | Note 3 |
| 3 | High Temperature Storage | $60 \pm 2^{\circ}\text{C}$ | Note 3 |
| 4 | Low Temperature Storage | $-20 \pm 2^{\circ}\text{C}$ | Note 3 |
| 5 | Vibration Test (Non-operation state) | Total fixed amplitude : 1.5mm Vibration Frequency : 10 ~ 55Hz One cycle 60 seconds to 3 directions of X.Y.Z. for each 15 minutes | Note 3 |
| 6 | Damp Proof Test (Non-operation state) | $40^{\circ}\text{C} \pm 2^{\circ}\text{C}$, 90~95%RH, 96h | Note 1,2 |
| 7 | Shock Test (Non-operation state) | To be measured after dropping from 60cm high once concrete surface in packing state | Note 3 |

Note 1: Returned under normal temperature and humidity for 4 hrs.

Note 2: No dew condensation to be observed.

Note 3: No change on display and in operation under the test condition

12.2 Inspection condition

12.2.1 Inspection conditions

The LCD shall be inspected under 40W white fluorescent light.

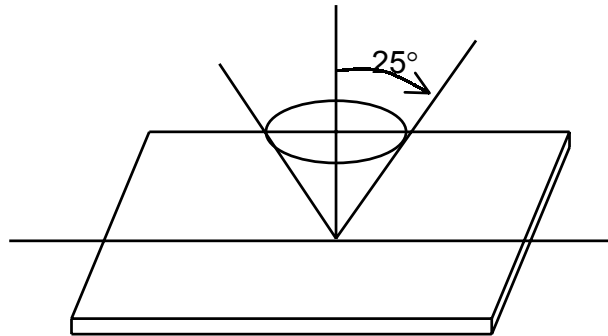

12.2.2 Definition of applicable Zones

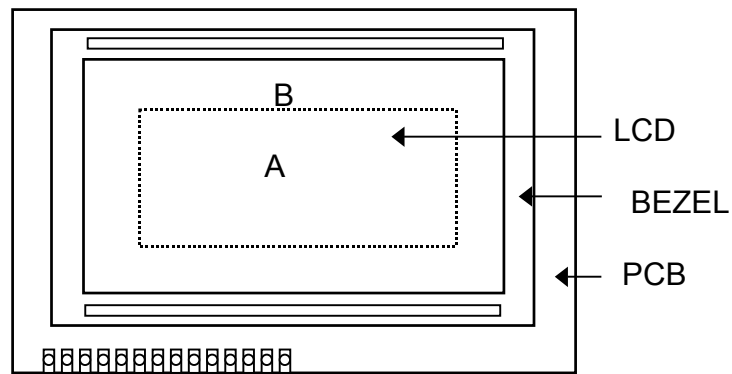

A : Display Area
B : Non-Display Area

12.2.3 Inspection Parameters

| No. | Parameter | Criteria | | | | | | | | | | | | | | | | |
|------------------------|--|---|------------------------|------------------------|------------------------|------------------|-----------|---------|----------|-----|---------------|-----|---------------|-----------------|---------|---------|----------------|---|
| 1 | Black or White spots | <table border="1"> <thead> <tr> <th>Zone Dimension</th> <th>Acceptable number A</th> <th>Class Of Defects</th> <th>AQL Level</th> </tr> </thead> <tbody> <tr> <td>D < 0.2</td> <td>*</td> <td rowspan="4">Minor</td> <td rowspan="4">2.5</td> </tr> <tr> <td>0.2 ≤ D < 0.3</td> <td>10</td> </tr> <tr> <td>0.3 ≤ D < 0.4</td> <td>5</td> </tr> <tr> <td>0.4 ≤ D</td> <td>0</td> </tr> </tbody> </table> <p>D = (Long + Short) / 2 * : Disregard</p> | Zone Dimension | Acceptable number A | Class Of Defects | AQL Level | D < 0.2 | * | Minor | 2.5 | 0.2 ≤ D < 0.3 | 10 | 0.3 ≤ D < 0.4 | 5 | 0.4 ≤ D | 0 | | |
| Zone Dimension | Acceptable number A | Class Of Defects | AQL Level | | | | | | | | | | | | | | | |
| D < 0.2 | * | Minor | 2.5 | | | | | | | | | | | | | | | |
| 0.2 ≤ D < 0.3 | 10 | | | | | | | | | | | | | | | | | |
| 0.3 ≤ D < 0.4 | 5 | | | | | | | | | | | | | | | | | |
| 0.4 ≤ D | 0 | | | | | | | | | | | | | | | | | |
| 2 | Scratch, Substances | <table border="1"> <thead> <tr> <th colspan="2">Zone L (mm) \ W(mm)</th> <th>Acceptable number A</th> <th>Class Of Defects</th> <th>AQL Level</th> </tr> </thead> <tbody> <tr> <td>L ≤ 2.0</td> <td>W ≤ 0.03</td> <td>*</td> <td rowspan="3">Minor</td> <td rowspan="3">2.5</td> </tr> <tr> <td>L ≤ 3.0</td> <td>0.03 < W ≤ 0.05</td> <td>6</td> </tr> <tr> <td>L ≤ 2.5</td> <td>0.05 < W ≤ 0.1</td> <td>1</td> </tr> </tbody> </table> <p>L : Length W : Width * : Disregard</p> | Zone L (mm) \ W(mm) | | Acceptable number A | Class Of Defects | AQL Level | L ≤ 2.0 | W ≤ 0.03 | * | Minor | 2.5 | L ≤ 3.0 | 0.03 < W ≤ 0.05 | 6 | L ≤ 2.5 | 0.05 < W ≤ 0.1 | 1 |
| Zone L (mm) \ W(mm) | | Acceptable number A | Class Of Defects | AQL Level | | | | | | | | | | | | | | |
| L ≤ 2.0 | W ≤ 0.03 | * | Minor | 2.5 | | | | | | | | | | | | | | |
| L ≤ 3.0 | 0.03 < W ≤ 0.05 | 6 | | | | | | | | | | | | | | | | |
| L ≤ 2.5 | 0.05 < W ≤ 0.1 | 1 | | | | | | | | | | | | | | | | |
| 3 | Air Bubbles (between glass & polarizer) | <table border="1"> <thead> <tr> <th>Zone Dimension</th> <th>Acceptable number A</th> <th>Class of Defects</th> <th>AQL Level</th> </tr> </thead> <tbody> <tr> <td>D ≤ 0.2</td> <td>*</td> <td rowspan="4">Minor</td> <td rowspan="4">2.5</td> </tr> <tr> <td>0.2 < D ≤ 0.3</td> <td>12</td> </tr> <tr> <td>0.3 < D ≤ 0.5</td> <td>3</td> </tr> <tr> <td>0.5 < D</td> <td>0</td> </tr> </tbody> </table> <p>* : Disregard</p> | Zone Dimension | Acceptable number A | Class of Defects | AQL Level | D ≤ 0.2 | * | Minor | 2.5 | 0.2 < D ≤ 0.3 | 12 | 0.3 < D ≤ 0.5 | 3 | 0.5 < D | 0 | | |
| Zone Dimension | Acceptable number A | Class of Defects | AQL Level | | | | | | | | | | | | | | | |
| D ≤ 0.2 | * | Minor | 2.5 | | | | | | | | | | | | | | | |
| 0.2 < D ≤ 0.3 | 12 | | | | | | | | | | | | | | | | | |
| 0.3 < D ≤ 0.5 | 3 | | | | | | | | | | | | | | | | | |
| 0.5 < D | 0 | | | | | | | | | | | | | | | | | |
| 4 | Uniformity of Pixel | <p>(1) Pixel shape (with Dent)</p> | | | | | | | | | | | | | | | | |

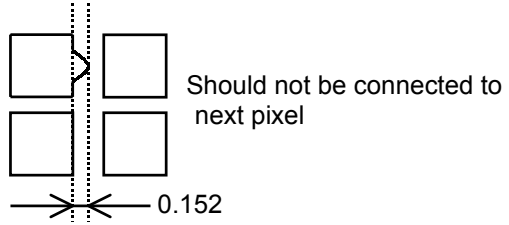
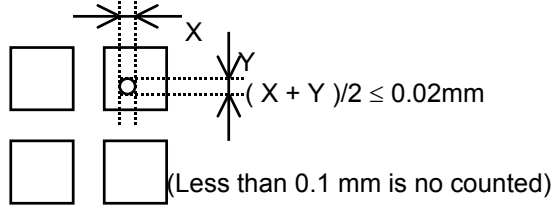
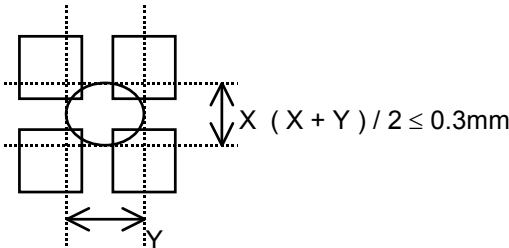
| | | | |
|------------------|---------------------|---|--|
| 4 | Uniformity of Pixel | (2) Pixel shape (with Projection) | |
| | |  <p>Should not be connected to next pixel</p> | |
| | | (3) Pin hole | |
| | |  <p>(Less than 0.1 mm is no counted)</p> | |
| | | (4) Deformation | |
| | |  <p>$(X + Y) / 2 \leq 0.3\text{mm}$</p> | |
| | | Total acceptable number : 1/pixel, 5/cell | |
| Class of defects | Major | AQL 0.65% | Definition |
| | | AQL 1.00% | It is a defect that is likely to result in failure or to reduce materially the usability of the product for the intended function. |
| | Minor | AQL 2.5% | It is a defect that is likely to assembly size and not result in functioning problem. |
| | | It is a defect that will not result in functioning problem with deviation classified. | |

12.3 Sampling Condition

Unless otherwise agree in written, the sampling inspection shall be applied to the incoming inspection of customer.

Lot size: Quantity of shipment lot per model.

Sampling type: normal inspection, single sampling

Inspection level: Level II

Sampling table: MIL-STD-105E

13. LOT NUMBERING SYSTEM

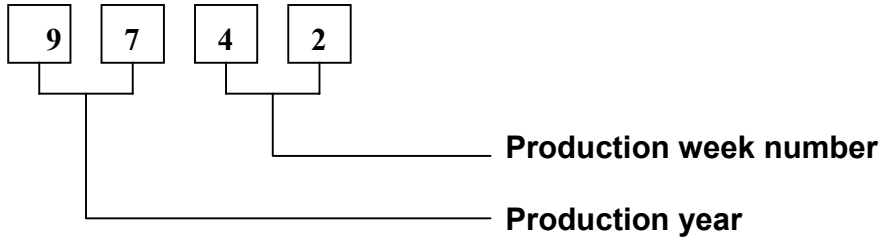

14. LCM NUMBERING SYSTEM

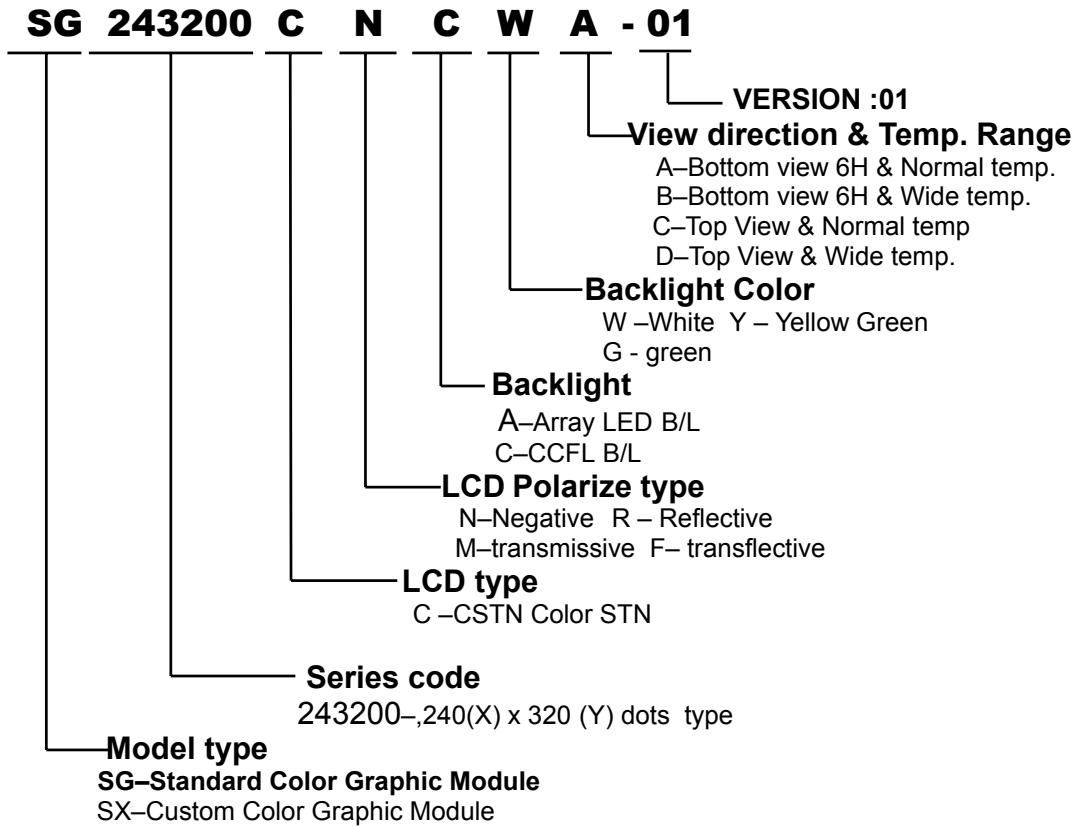

15. PRECAUTION FOR USING LCM

1. LIQUID CRYSTAL DISPLAY (LCD)

LCD is made up of glass, organic sealant, organic fluid, and polymer based polarizers. The following precautions should be taken when handling,

- (1). Keep the temperature within range of use and storage. Excessive temperature and humidity could cause polarization degradation, polarizer peel off or bubble.
- (2). Do not contact the exposed polarizers with anything harder than an HB pencil lead. To clean dust off the display surface, wipe gently with cotton, chamois or other soft material soaked in petroleum benzine.
- (3). Wipe off saliva or water drops immediately. Contact with water over a long period of time may cause polarizer deformation or color fading, while an active LCD with water condensation on its surface will cause corrosion of ITO electrodes.
- (4). Glass can be easily chipped or cracked from rough handling, especially at corners and edges.
- (5). Do not drive LCD with DC voltage.

2. Liquid Crystal Display Modules

2.1 Mechanical Considerations

LCM are assembled and adjusted with a high degree of precision. Avoid excessive shocks and do not make any alterations or modifications. The following should be noted.

- (1). Do not tamper in any way with the tabs on the metal frame.
- (2). Do not modify the PCB by drilling extra holes, changing its outline, moving its components or modifying its pattern.
- (3). Do not touch the elastomer connector, especially insert an backlight panel (for example, EL).
- (4). When mounting a LCM make sure that the PCB is not under any stress such as bending or twisting. Elastomer contacts are very delicate and missing pixels could result from slight dislocation of any of the elements.
- (5). Avoid pressing on the metal bezel, otherwise the elastomer connector could be deformed and lose contact, resulting in missing pixels.

2.2 Static Electricity

LCM contains CMOS LSI's and the same precaution for such devices should apply, namely

- (1). The operator should be grounded whenever he/she comes into contact with the module. Never touch any of the conductive parts such as the LSI pads, the copper leads on the PCB and the interface terminals with any parts of the human body.
- (2). The modules should be kept in antistatic bags or other containers resistant to static for storage.
- (3). Only properly grounded soldering irons should be used.
- (4). If an electric screwdriver is used, it should be well grounded and shielded from commutator sparks.

- (5) The normal static prevention measures should be observed for work clothes and working benches; for the latter conductive (rubber) mat is recommended.
- (6). Since dry air is inductive to statics, a relative humidity of 50-60% is recommended.

2.3 Soldering

- (1). Solder only to the I/O terminals.
- (2). Use only soldering irons with proper grounding and no leakage.
- (3). Soldering temperature : $280^{\circ}\text{C} \pm 10^{\circ}\text{C}$
- (4). Soldering time: 3 to 4 sec.
- (5). Use eutectic solder with resin flux fill.
- (6). If flux is used, the LCD surface should be covered to avoid flux spatters. Flux residue should be removed afterwards.

2.4 Operation

- (1). The viewing angle can be adjusted by varying the LCD driving voltage V_0 .
- (2). Driving voltage should be kept within specified range; excess voltage shortens display life.
- (3). Response time increases with decrease in temperature.
- (4). Display may turn black or dark blue at temperatures above its operational range; this is (however not pressing on the viewing area) may cause the segments to appear "fractured".
- (5). Mechanical disturbance during operation (such as pressing on the viewing area) may cause the segments to appear "fractured".

2.5 Storage

If any fluid leaks out of a damaged glass cell, wash off any human part that comes into contact with soap and water. Never swallow the fluid. The toxicity is extremely low but caution should be exercised at all the time.

2.6 Limited Warranty

Unless otherwise agreed between DATA IMAGE and customer, DATA IMAGE will replace or repair any of its LCD and LCM which is found to be defective electrically and visually when inspected in accordance with DATA IMAGE acceptance standards, for a period on one year from date of shipment. Confirmation of such date shall be based on freight documents. The warranty liability of DATA IMAGE is limited to repair and/or replacement on the terms set forth above. DATA IMAGE will not be responsible for any subsequent or consequential events.

16.OUTLINE DRAWING

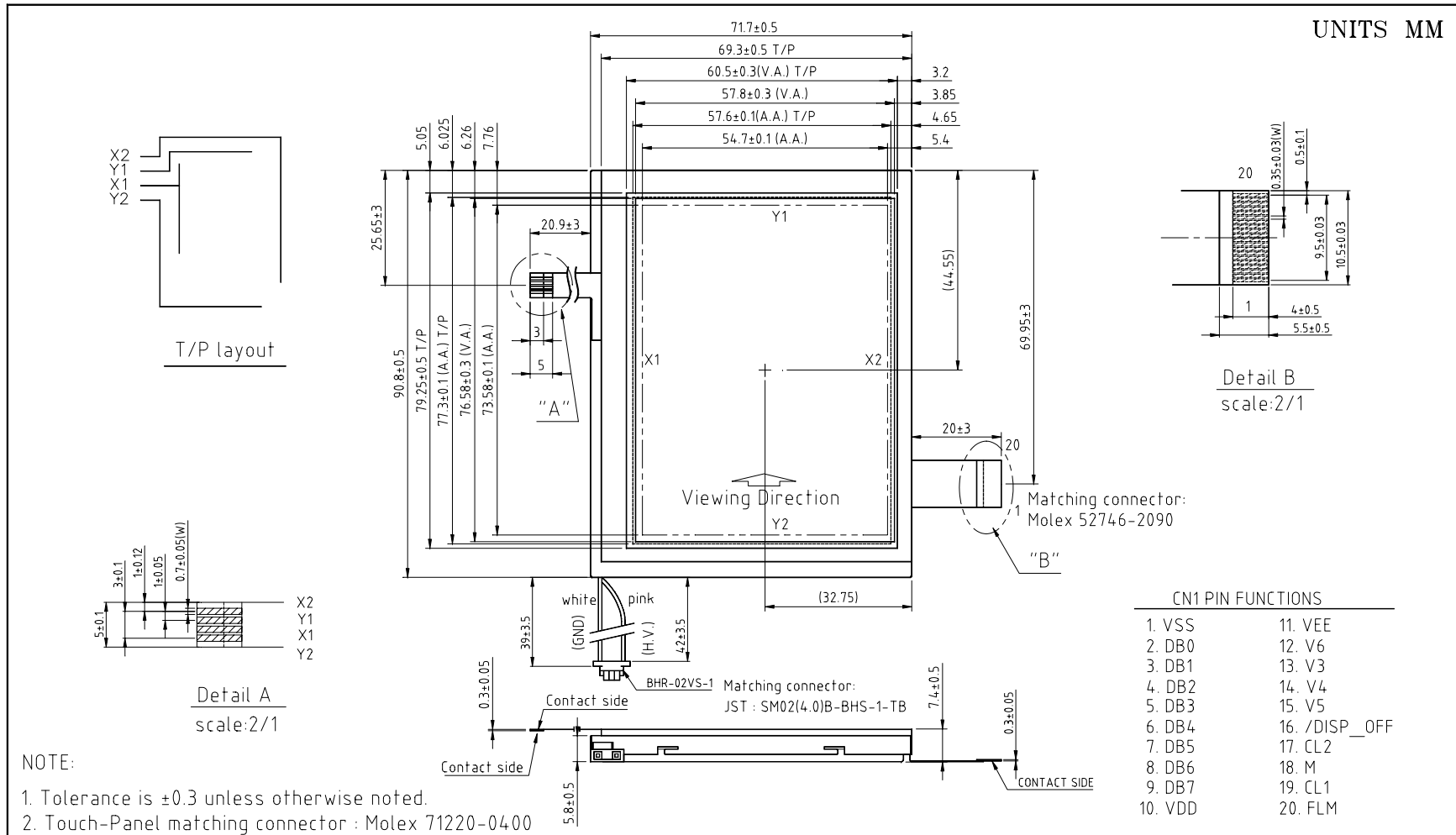

UNITS MM

Detail B
scale:2/1

Detail A
scale:2/1

CN1 PIN FUNCTIONS

| | |
|---------|---------------|
| 1. VSS | 11. VEE |
| 2. DB0 | 12. V6 |
| 3. DB1 | 13. V3 |
| 4. DB2 | 14. V4 |
| 5. DB3 | 15. V5 |
| 6. DB4 | 16. /DISP_OFF |
| 7. DB5 | 17. CL2 |
| 8. DB6 | 18. M |
| 9. DB7 | 19. CL1 |
| 10. VDD | 20. FLM |

NOTE:

1. Tolerance is ±0.3 unless otherwise noted.
2. Touch-Panel matching connector : Molex 71220-0400

| | | | | | | | |
|-----------|-------------|------|----------|-------------|-----------|-------------------------------------|--------------------|
| | | | | ISSUE DATE: | 08/14/02' | DATA IMAGE Corporation | |
| | | | | DRAWN: | Roger | TITLE: LCM OUTLINE DIMENSION | |
| | | | | CHECK: | | A4 | DWG. NO. Q020815 |
| AUTH | DESCRIPTION | DATE | APPROVED | APPROVE: | | | PART. NO. SG243200 |
| REVISIONS | | | | | | SCALE : 5/6 | SHEET 1 OF 1 |

17. PACKAGE INFORMATION

