

# Digital Switched-Mode Power Supply (SMPS)

## Overview

The main purpose of a power supply is to provide clean and stable power to a load, regardless of power grid conditions. The SMPS has been widely used in office

equipment, computers, communication systems and other applications because of its high efficiency and high energy density.

## Key Benefits

- > Power applications become more flexible and universal
- > High input power factor lowers power pollution to the power grid
- > Intelligent mode management and fault supervision
- > Operating status can be monitored and controlled in real time
- > Lower system and maintenance cost

### EXAMPLE DIGITAL SMPS

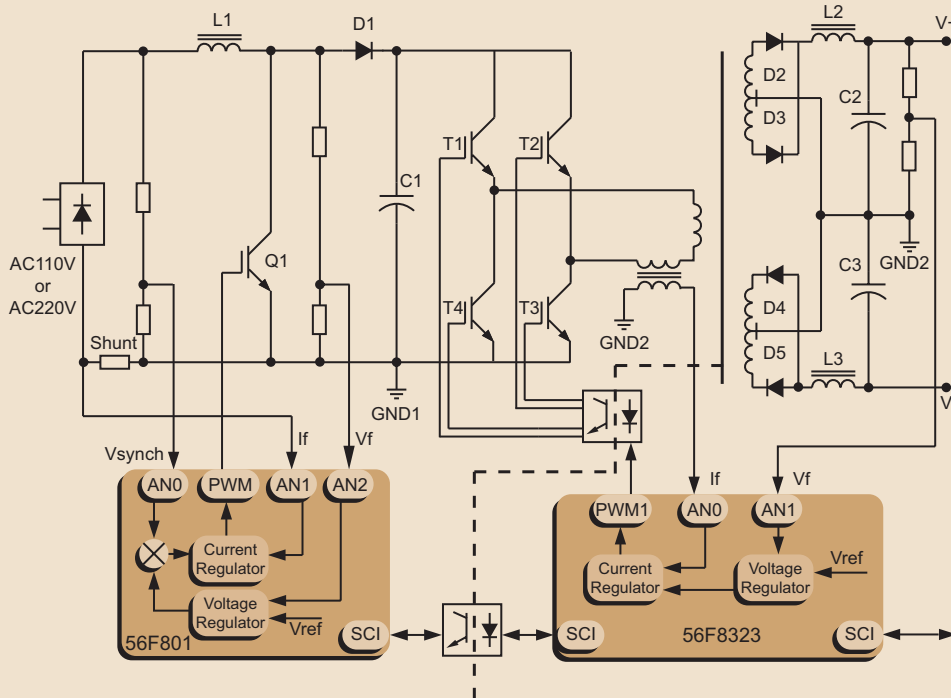

## Freescale Ordering Information

Part Number	Product Highlights	Additional Information
DSP56F801	80 MHz, 40 MIPS, SCI, SPI, ADC, PWM, Quad Timer and > 8K Program Flash > 1K Program RAM > 2K Data Flash > 1K Data RAM	MCU-friendly instruction set, OnCE for debug, on-chip relaxation oscillator, 2K BootFLASH and up to 11 GPIO available in a 48-pin LQFP.
DSP56F802	80 MHz, 40 MIPS, SCI, SPI, ADC, PWM, Quad Timer and > 8K Program Flash > 1K Program RAM > 2K Data Flash > 1K Data RAM	MCU-friendly instruction set, OnCE for debug, on-chip relaxation oscillator, 2K BootFLASH and up to 4 GPIO available in a 32-pin LQFP.
DSP56F803	80 MHz, 40 MIPS, CAN, SCI, SPI, ADC, PWMs, Quadrature Decoder, Quad Timer and > 31.5K Program Flash > 512K Program RAM > 4K Data Flash > 2K Data RAM	MCU-friendly instruction set, OnCE for debug, on-chip relaxation oscillator, 2K BootFLASH, external memory expansion, and up to 16 GPIO available in a 100-pin LQFP.
MC56F8322	60 MHz, 60 MIPS, 2 SPI, 2 SCI, 2 ADC, PWM, COP, PLL, Decoder, 2 Quad Timers, FlexCAN, an MCU-friendly instruction set, Enhanced OnCE for debug, on-chip relaxation oscillator, and temperature sensor with > 48KB Flash > 12KB RAM	Industrial (-40°C to 105°C) and Extended (-40°C to 125°C) Temperature Ranges with up to 21 GPIOs in a 48-pin LQFP
MC56F8323	60 MHz, 60 MIPS, 2 SPI, 2 SCI, 2 ADC, PWM, COP, PLL, Decoder, 2 Quad Timers, FlexCAN, an MCU-friendly instruction set, Enhanced OnCE for debug, on-chip relaxation oscillator, and temperature sensor with > 48KB Flash > 12KB RAM	Industrial (-40°C to 105°C) and Extended (-40°C to 125°C) Temperature Ranges with up to 27 GPIOs in a 64-pin LQFP

### Design Challenges

Presently, the vast majority of SMPS are implemented in an analog fashion. But analog implementations have significant disadvantages that can be rectified by implementing the SMPS using modern digital mechanisms. Until recently, this has not been cost effective, due to performance and cost of the processors required to do the job. The 56F800 and 56F8300 hybrid controllers specified here have the required performance, peripherals, and price targets to enable SMPS to make the conversion from analog to digital implementations.

### Freescale Semiconductor Solution

The digital 56800/E Switched-Mode Power Supply minimizes the number of system components, maximizes the system reliability, and makes it possible to easily add advanced functions without increasing cost.

The performance, integrated peripherals, and low cost of the 56F800 and 56F8300 controllers specified here make the digital SMPS possible and practical.

The system in this example is a 100-Watt SMPS controlled by a 56F801 device on the primary side and a 56F8323 on the secondary side. Optional components could include user interfaces, such as an LCD or LED display.

During normal operation, an AC/DC rectifier controlled by a 56F801 will correct the input power factor while simultaneously rectifying the AC input voltage. The output of the AC/DC rectifier is a DC voltage that will feed the DC/DC converter, which is controlled by a 56F8323 device. The DC/DC converter has a full bridge topology, used to convert the DC Bus voltage to a precise and constant DC output voltage. For the Power Factor Correction (PFC) converter, the 56F801 samples the input AC voltage, input AC current, and DC output voltage. The output DC voltage is regulated by the 56F801, while maintaining the same phase for both the AC input current and voltage. The PWM module on the 56F801 produces the

PWM pulse for the PFC main power component. The DC/DC converter controlled by the 56F8323 is operating on a phase-shifted soft-switching mode, so that switching losses and noise can be kept to a minimum.

Control functions implemented within the primary hybrid controller are:

- > Input power factor correction
- > Automatic detection of input voltage frequency

Control functions implemented within the secondary hybrid controller are:

- > Power on/off control
- > DC Bus voltage regulation
- > Output DC voltage regulation
- > DC/DC full-bridge phase-shifted control strategy
- > Power system monitoring and communication protocols (optional)
- > Fault and mode management

### *Development Tools*

Tool Type	Product Name	Vendor	Description
Software	CW568X	Freescale Semiconductor	CodeWarrior™ Development Studio for 56800/E Hybrid Controllers With Processor Expert (Metrowerks)
Hardware	MC56F8300DSK	Freescale Semiconductor	56F8300 Developers Starter Kit
Hardware	56F800DEMO	Freescale Semiconductor	56F800 Demonstration kit
Hardware	DSP56F801EVM	Freescale Semiconductor	Evaluation Module for 56F801 Processor
Hardware	DSP56F803EVM	Freescale Semiconductor	Evaluation Module for 56F803 Processor
Hardware	MC56F8323EVM	Freescale Semiconductor	Evaluation Module for 56F8322 and 56F8323 Hybrid Controllers

#### ***Disclaimer***

This document may not include all the details necessary to completely develop this design. It is provided as a reference only and is intended to demonstrate the variety of applications for the device.

## Notes

**Learn More:** Contact the Technical Information Center at +1-800-521-6247 or +1-480-768-2130.  
For more information about Freescale products, please visit [www.freescale.com](http://www.freescale.com).

Freescale™ and the Freescale logo are trademarks of Freescale Semiconductor, Inc.  
All other product or service names are the property of their respective owners.  
© Freescale Semiconductor, Inc. 2004. All rights reserved.

SG2074  
REV 1  
12/2004

December2004

