

DATA SHEET

OM4068 LCD driver for low multiplex rates

Product specification
File under Integrated Circuits, IC12

1998 Jun 18

LCD driver for low multiplex rates

OM4068

FEATURES

- Single-chip LCD controller/driver
- Static/duplex/triplex drive modes with up to 32/64/96 LCD segments drive capability per device
- Selectable backplane drive configuration: static or 2 or 3 backplane multiplexing
- Selectable display bias configuration drive: static, $\frac{1}{2}$ or $\frac{1}{3}$
- 32 segment drivers
- Serial data input (word length 32 to 96 bits)
- On-chip generation of intermediate LCD bias voltages
- 2 MHz fast serial bus interface
- CMOS compatible
- Compatible with any 4-bit, 8-bit or 16-bit microprocessors/microcontrollers
- May be cascaded for large LCD applications
- Logic supply voltage range ($V_{DD} - V_{SS}$) of 2.5 to 5.5 V
- Display supply voltage range ($V_{LCD} - V_{SS}$) of 3.5 to 6.5 V
- Low power consumption, suitable for battery operated systems
- No external components needed by the oscillator
- Manufactured in silicon gate CMOS process.

APPLICATIONS

- Telecom equipment
- Portable instruments
- Alarm systems
- Automotive equipment.

GENERAL DESCRIPTION

The OM4068 is a low-power CMOS LCD driver, designed to drive Liquid Crystal Displays (LCDs) with low multiplex rates. It generates the drive signals for any static or multiplexed LCD containing up to three backplanes and up to 32 segment lines and can be easily cascaded for larger LCD applications. All necessary functions for the display are provided in a single chip, including on-chip generation of LCD bias voltages, resulting in a minimum of external components and lower power consumption. A 3-line bus structure enables serial data transfer with most microprocessors/microcontrollers. All inputs are CMOS compatible.

ORDERING INFORMATION

TYPE NUMBER	PACKAGE		
	NAME	DESCRIPTION	VERSION
OM4068H ⁽¹⁾	QFP44	plastic quad flat package; 44 leads (lead length 1.3 mm); body 10 × 10 × 1.75 mm	SOT307-2
OM4068P	DIP40	plastic dual in-line package; 40 leads (600 mil)	SOT129-1
OM4068U/5 ⁽²⁾	die	unsawn wafer	–
OM4068U	tray	chip in tray	–

Notes

1. Gull Wing package.
2. For details see Chapter "Bonding pad locations".

LCD driver for low multiplex rates

OM4068

BLOCK DIAGRAM

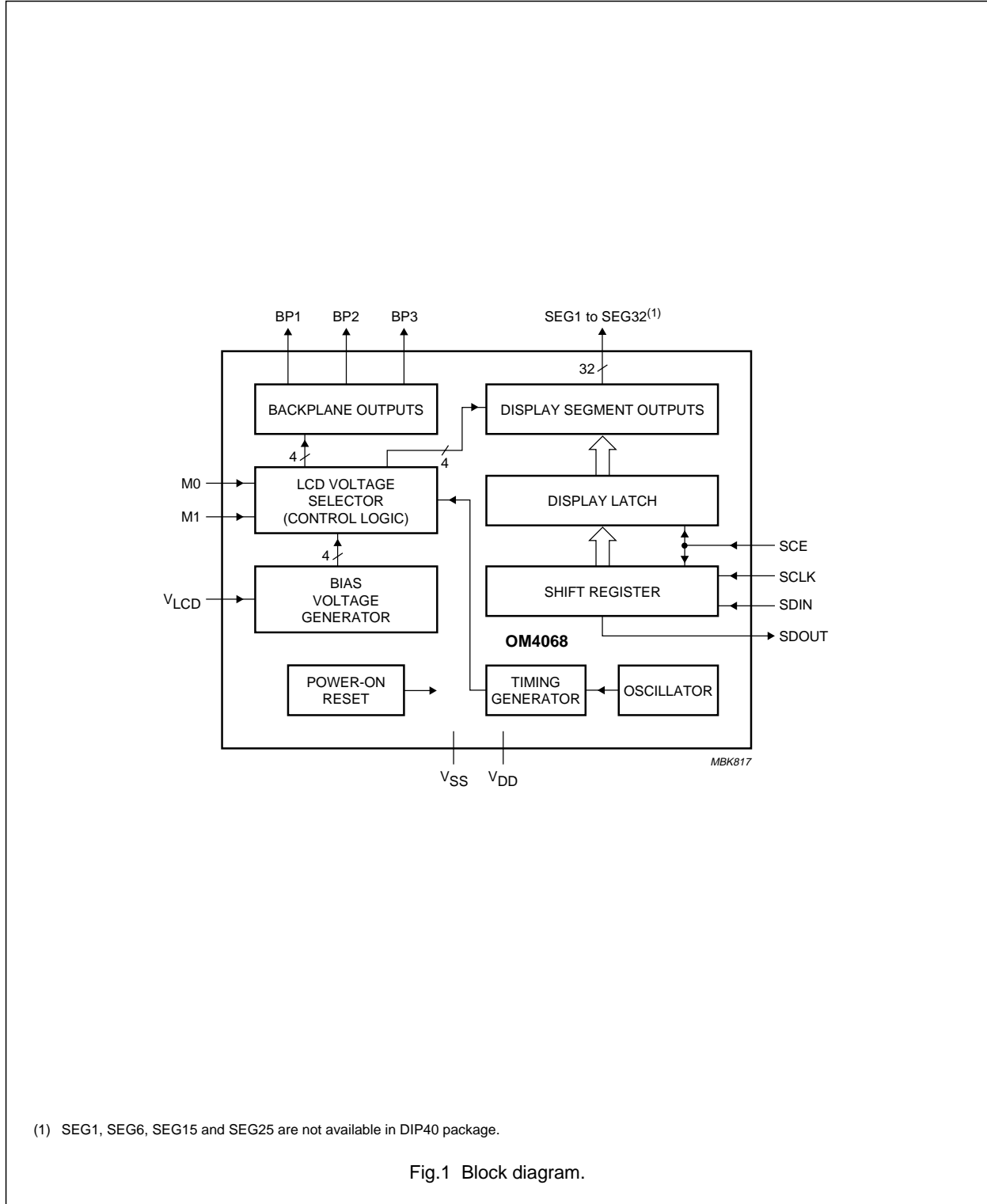

(1) SEG1, SEG6, SEG15 and SEG25 are not available in DIP40 package.

Fig.1 Block diagram.

LCD driver for low multiplex rates

OM4068

PINNING

See notes 1 to 8.

SYMBOL	PIN		DESCRIPTION
	QFP44	DIP40	
V _{LCD}	4	19	LCD supply voltage
V _{DD}	5	20	positive supply voltage
V _{SS}	6	21	ground
M0	7	22	drive mode select input 0
M1	8	23	drive mode select input 1
SDIN	9	24	serial bus data input
SCLK	10	25	serial bus clock input
SCE	11	26	serial bus clock enable
SDOUT	12	27	serial bus data output
BP1	13	28	LCD backplane driver output 1
BP2	14	29	LCD backplane driver output 2
BP3	15	30	LCD backplane driver output 3
SEG1	16	–	LCD segment driver output 1
SEG2	17	31	LCD segment driver output 2
SEG3	18	32	LCD segment driver output 3
SEG4	19	33	LCD segment driver output 4
SEG5	20	34	LCD segment driver output 5
SEG6	21	–	LCD segment driver output 6
SEG7	22	35	LCD segment driver output 7
SEG8	23	36	LCD segment driver output 8
SEG9	24	37	LCD segment driver output 9
SEG10	25	38	LCD segment driver output 10
SEG11	26	39	LCD segment driver output 11
SEG12	27	40	LCD segment driver output 12
SEG13	28	1	LCD segment driver output 13
SEG14	29	2	LCD segment driver output 14
SEG15	30	–	LCD segment driver output 15
SEG16	31	3	LCD segment driver output 16
SEG17	32	4	LCD segment driver output 17
SEG18	33	5	LCD segment driver output 18
SEG19	34	6	LCD segment driver output 19
SEG20	35	7	LCD segment driver output 20
SEG21	36	8	LCD segment driver output 21
SEG22	37	9	LCD segment driver output 22
SEG23	38	10	LCD segment driver output 23
SEG24	39	11	LCD segment driver output 24
SEG25	40	–	LCD segment driver output 25
SEG26	41	12	LCD segment driver output 26

LCD driver for low multiplex rates

OM4068

SYMBOL	PIN		DESCRIPTION
	QFP44	DIP40	
SEG27	42	13	LCD segment driver output 27
SEG28	43	14	LCD segment driver output 28
SEG29	44	15	LCD segment driver output 29
SEG30	1	16	LCD segment driver output 30
SEG31	2	17	LCD segment driver output 31
SEG32	3	18	LCD segment driver output 32

Notes

1. SEG1 to SEG32 (LCD segment driver outputs) output the multi-level signals for the LCD segments.
2. BP0, BP1 and BP2 (LCD backplane driver outputs) output the multi-level signals for the LCD backplanes.
3. V_{LCD} (LCD power supply): power supply for the LCD.
4. SDIN (serial data line): input for the bus data line.
5. SCL (serial clock line): input for the bus clock line.
6. SDOUT (serial data output): output of the shift register to allow serial cascading of the OM4068 with other devices.
7. SCE (serial clock enable): input for enable/disable acquisition on the data input line. If disabled, data on the serial bus are not accepted by the device.
8. M0 and M1 (display mode select inputs): inputs to select the LCD drive configurations; static, duplex or triplex.

LCD driver for low multiplex rates

OM4068

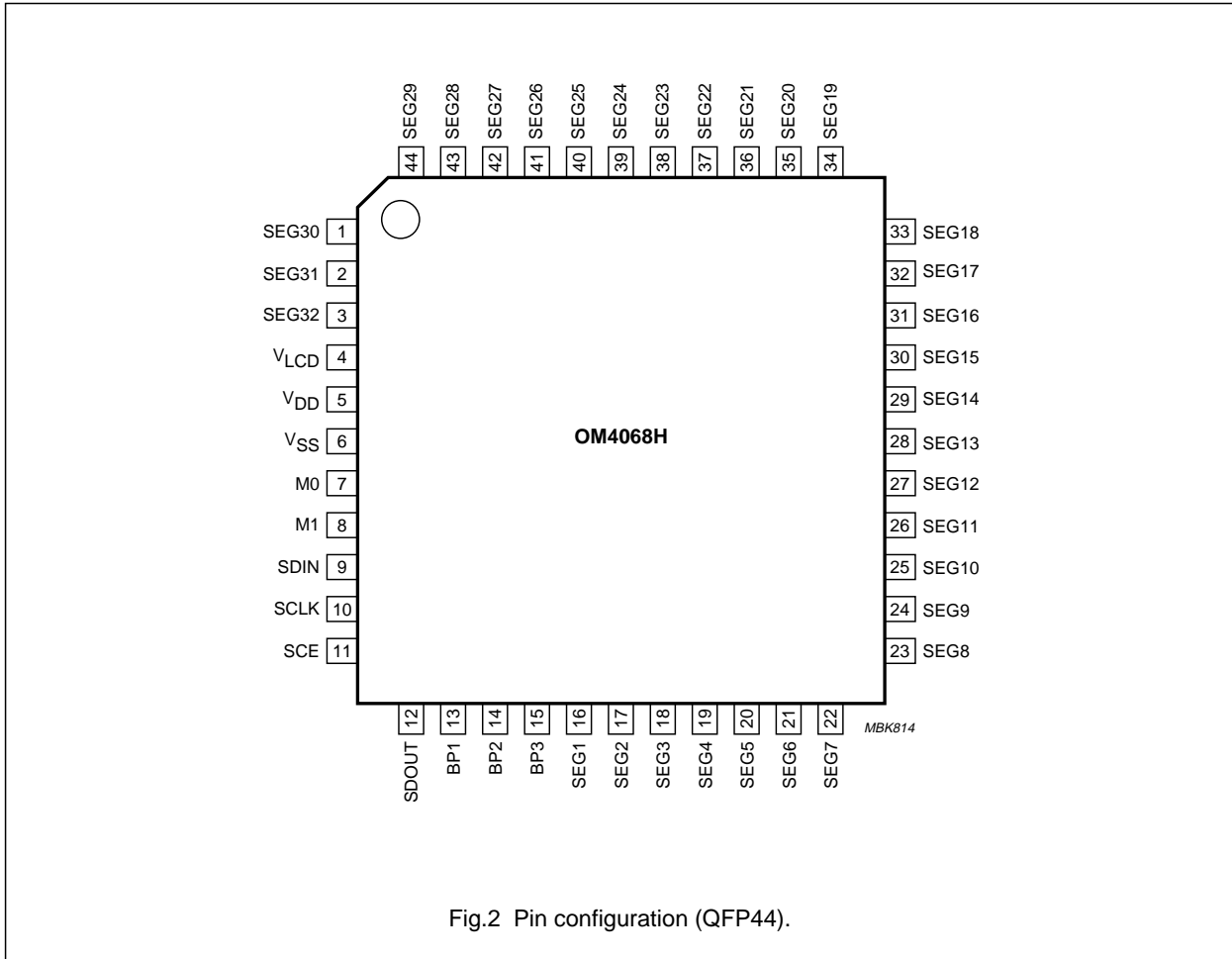

Fig.2 Pin configuration (QFP44).

LCD driver for low multiplex rates

OM4068

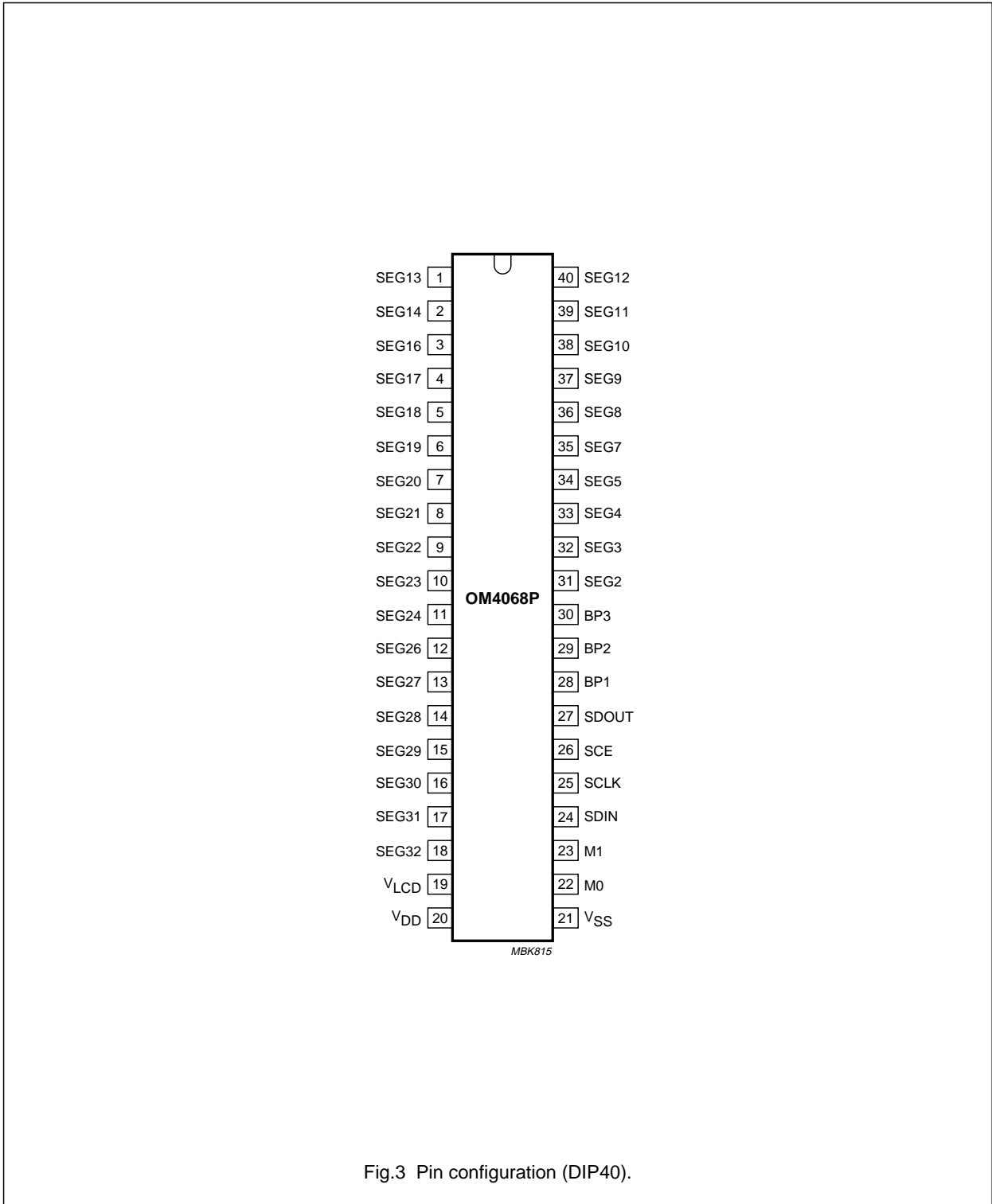

Fig.3 Pin configuration (DIP40).

LCD driver for low multiplex rates

OM4068

FUNCTIONAL DESCRIPTION

The OM4068 is a low-power LCD driver designed to interface with any microprocessor/microcontroller and a wide variety of LCDs. It can drive any static or multiplexed LCD containing up to three backplanes and up to 96 segments.

The display configurations possible with the OM4068 depend on the number of active backplane outputs required; a selection of display configurations is given in Table 1.

A typical system (MUX 1 : 3) is shown in Fig.4.

Table 1 Selection of display configurations

NUMBER OF		7-SEGMENTS NUMERIC		DOT MATRIX
BACKPLANES	DISPLAY SEGMENTS	DIGITS	INDICATOR SYMBOLS	
3	96	12	12	96 dots (3 × 32)
2	64	8	8	64 dots (2 × 32)
1	32	4	4	32 dots (1 × 32)

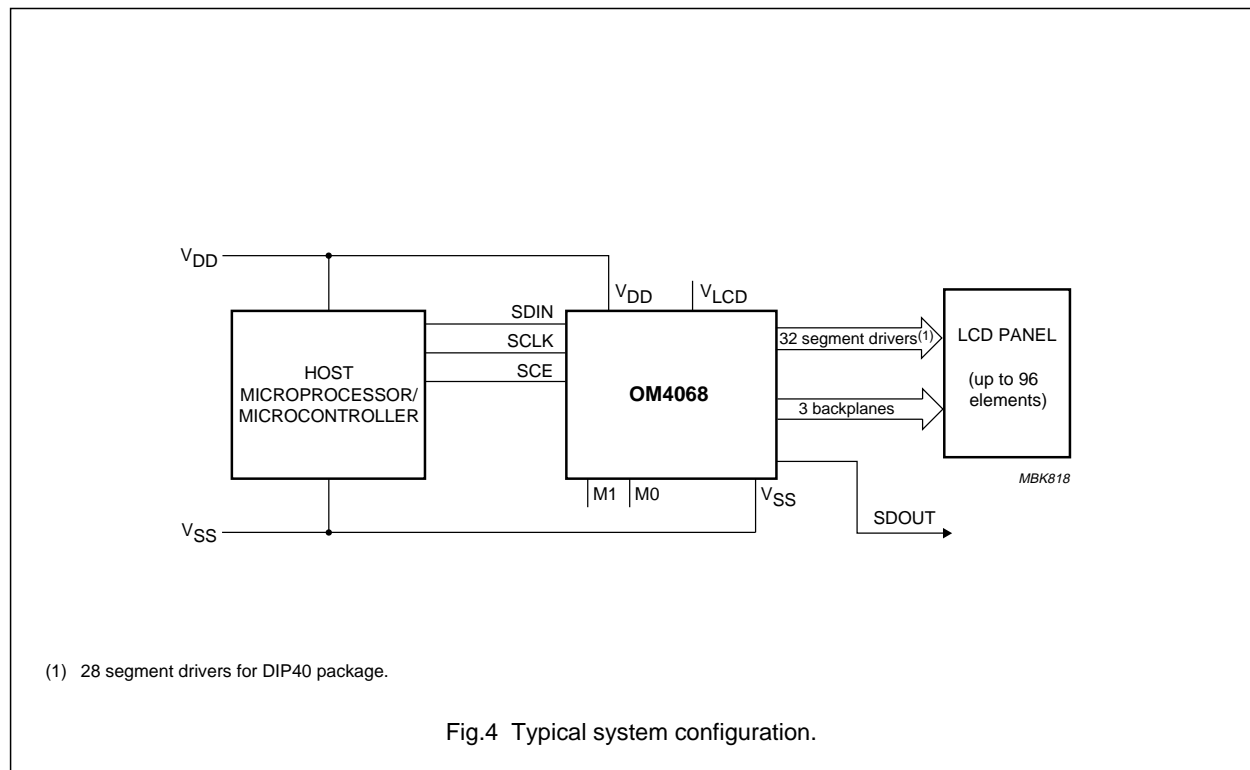

The host microprocessor/microcontroller maintains the 3-line bus communication channel with OM4068. The internal oscillator requires no external components. The appropriate intermediate biasing voltage for the multiplexed LCD waveforms are generated on-chip.

The only other connections required to complete the system are to the power supplies (V_{SS} , V_{DD} and V_{LCD}) and suitable capacitors to decouple the V_{LCD} and V_{DD} pins to V_{SS} .

LCD driver for low multiplex rates

OM4068

Power-on reset

The on-chip power-on reset block initializes the chip after power-on or power failures. The OM4068 resets to a starting condition as follows:

- All backplane and segment outputs are set to V_{SS} (display off)
- All shift registers and latches are set in 3-state
- SDOOUT (allowing serial cascading) is set to logic 0 (with SCE LOW)
- Power-down mode.

Data transfers on the serial bus should be avoided for 0.5 ms following power-on to allow completion of the reset action.

Power-down

After power-on the chip is in power-down mode as long as the serial clock is not active. During power-down all static currents are switched off (no internal oscillator, no timing and no bias level generation) and all LCD-outputs are 3-stated. The power-on reset functions remain enabled.

The power-down mode is disabled at the first rising edge of the serial clock SCLK.

LCD bias voltage generator

The intermediate bias voltages for the LCD display are generated on-chip. This removes the need for an external resistive bias chain and significantly reduces the system power consumption. The full-scale LCD voltage V_{OP} equals $V_{LCD} - V_{SS}$. The optimum value of V_{OP} depends on the LCD threshold voltage (V_{th}) and the number of bias levels.

Fractional LCD biasing voltages are obtained from an internal voltage divider of three series resistors ($\frac{1}{3}$ bias) connected between V_{LCD} and V_{SS} . The centre resistor can be switched out of the circuit to provide a $\frac{1}{2}$ bias voltage level for the 1 : 2 multiplex configuration.

The bias levels depend on the multiplex rate and are selected automatically when the display configuration is selected using M1 and M0.

LCD voltage selector

The LCD voltage selector (control logic) coordinates the multiplexing of the LCD in accordance with the selected drive or display configuration. The operation of the voltage selector is controlled by the input pins M0 and M1 (see Table 2).

Table 2 Drive mode selection

M1	M0	DRIVE MODE
0	0	test mode (not user accessible)
0	1	static drive (1 : 1)
1	0	duplex drive (1 : 2)
1	1	triplex drive (1 : 3)

For multiplex rates of 1 : 2 three bias levels are used including V_{LCD} and V_{SS} . Four bias level are used for the 1 : 3 multiplex rate. The various biasing configurations together with the biasing characteristics as functions of $V_{OP} = V_{LCD} - V_{SS}$ and the resulting discrimination ratios (D), are given in Table 3.

A practical value for V_{OP} is determined by equating $V_{off(rms)}$ with a defined LCD threshold voltage (V_{th}), typically when the LCD exhibits approximately 10% contrast. In static mode a suitable choice is $V_{OP} > 3V_{th}$.

LCD driver for low multiplex rates

OM4068

Table 3 LCD drive modes: summary of characteristics

LCD DRIVE MODE	NUMBER OF		LCD BIAS CONFIGURATION	$\frac{V_{off(rms)}}{V_{OP}}$	$\frac{V_{on(rms)}}{V_{OP}}$	$D = \frac{V_{on(rms)}}{V_{off(rms)}}$
	BACKPLANES	LEVELS				
Static	1	2	static	0	1	–
1 : 2	2	3	$\frac{1}{2}$	0.354	0.791	2.2236
1 : 3	3	4	$\frac{1}{3}$	0.333	0.638	1.915

LCD drive mode waveforms

The static LCD drive mode is used when a single backplane is provided in the LCD. Backplane and segment drive waveforms for this mode are shown in Fig.5.

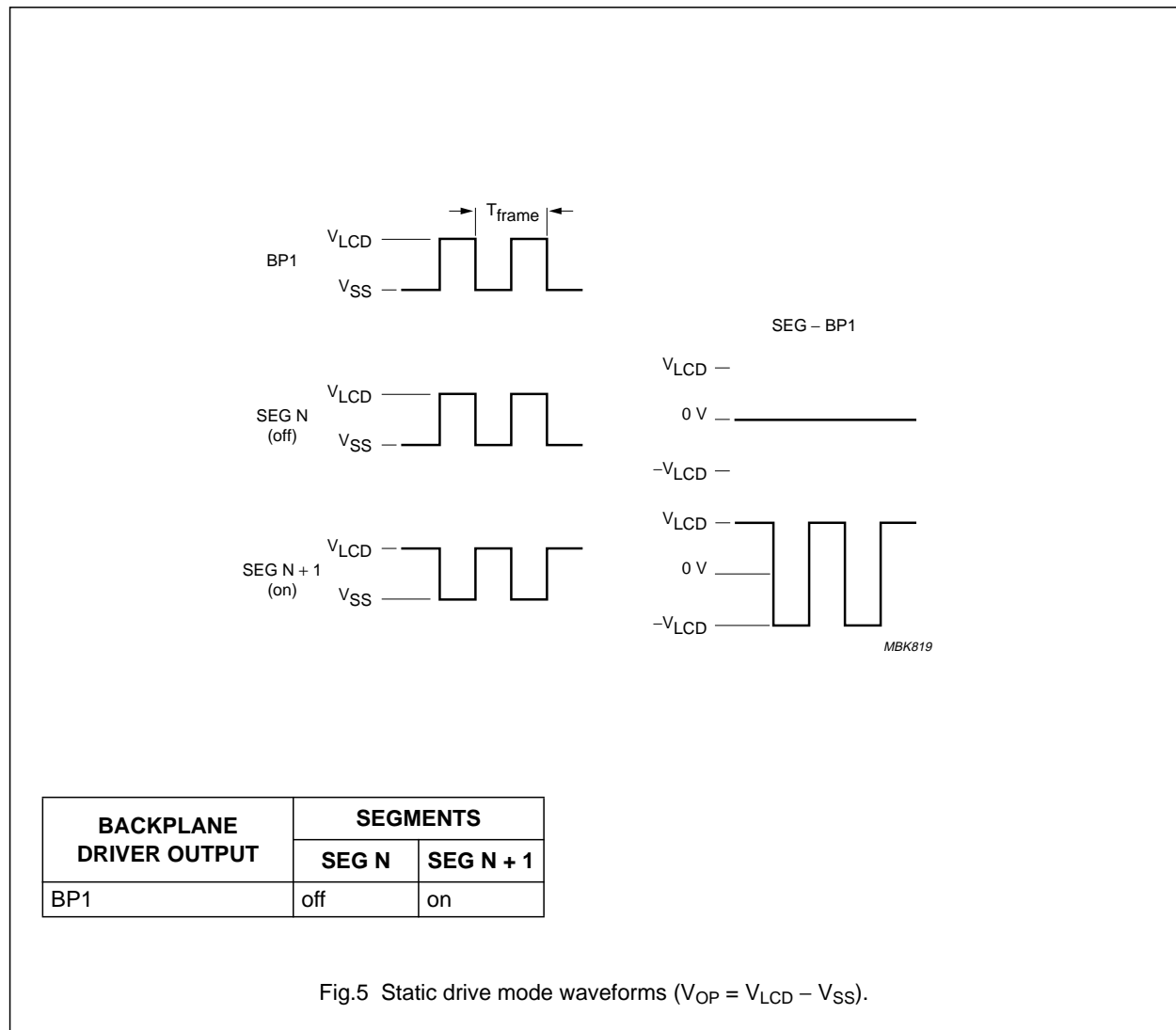

LCD driver for low multiplex rates

OM4068

1 : 2 MULTIPLEX DRIVE MODE

When two backplanes are provided in the LCD, the 1 : 2 multiplex mode applies, as shown in Fig.6.

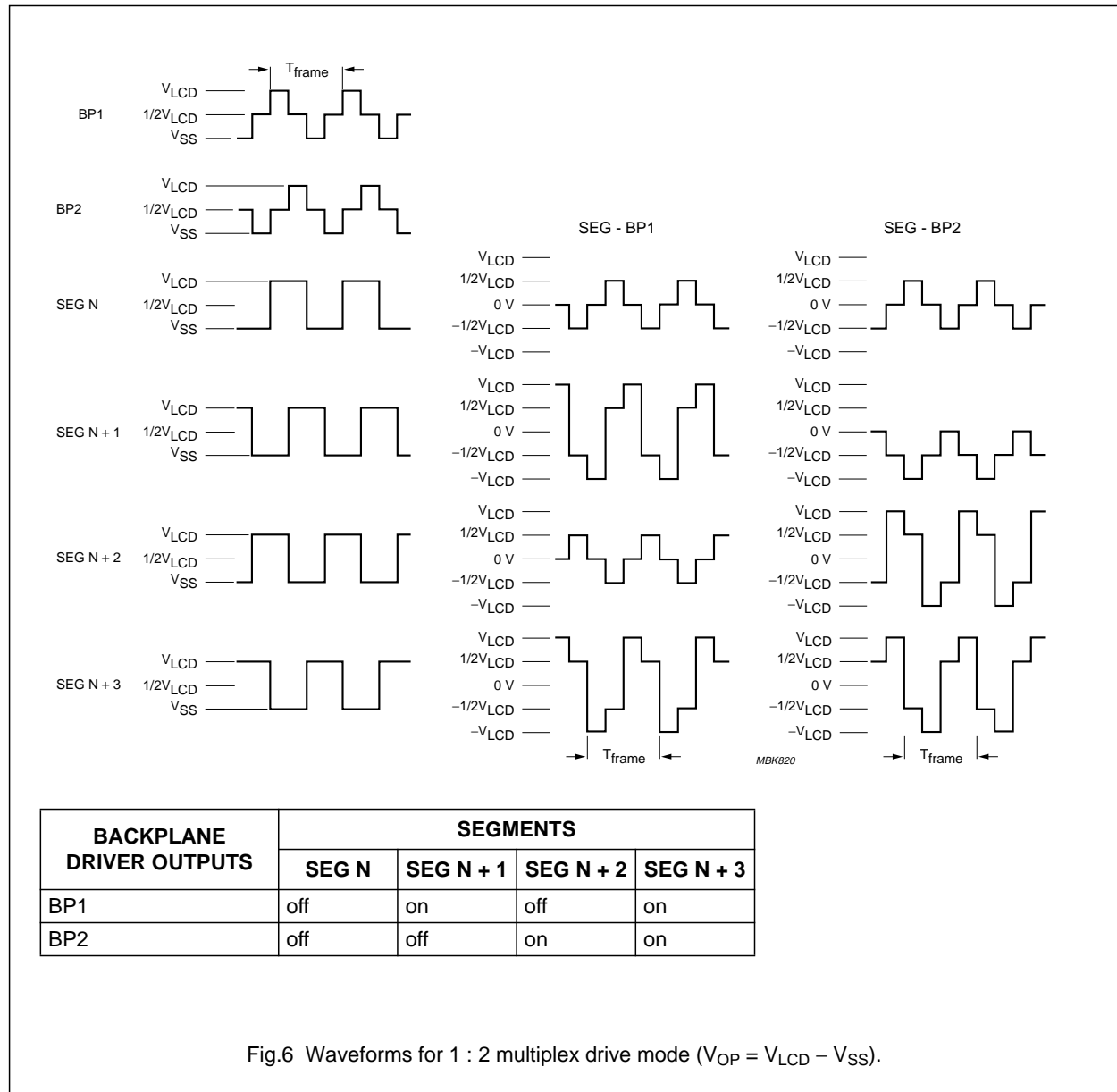

Fig.6 Waveforms for 1 : 2 multiplex drive mode ($V_{OP} = V_{LCD} - V_{SS}$).

1 : 3 MULTIPLEX DRIVE MODE

When three backplanes are provided in the LCD, the 1 : 3 multiplex mode applies, as shown in Fig.7.

LCD driver for low multiplex rates

OM4068

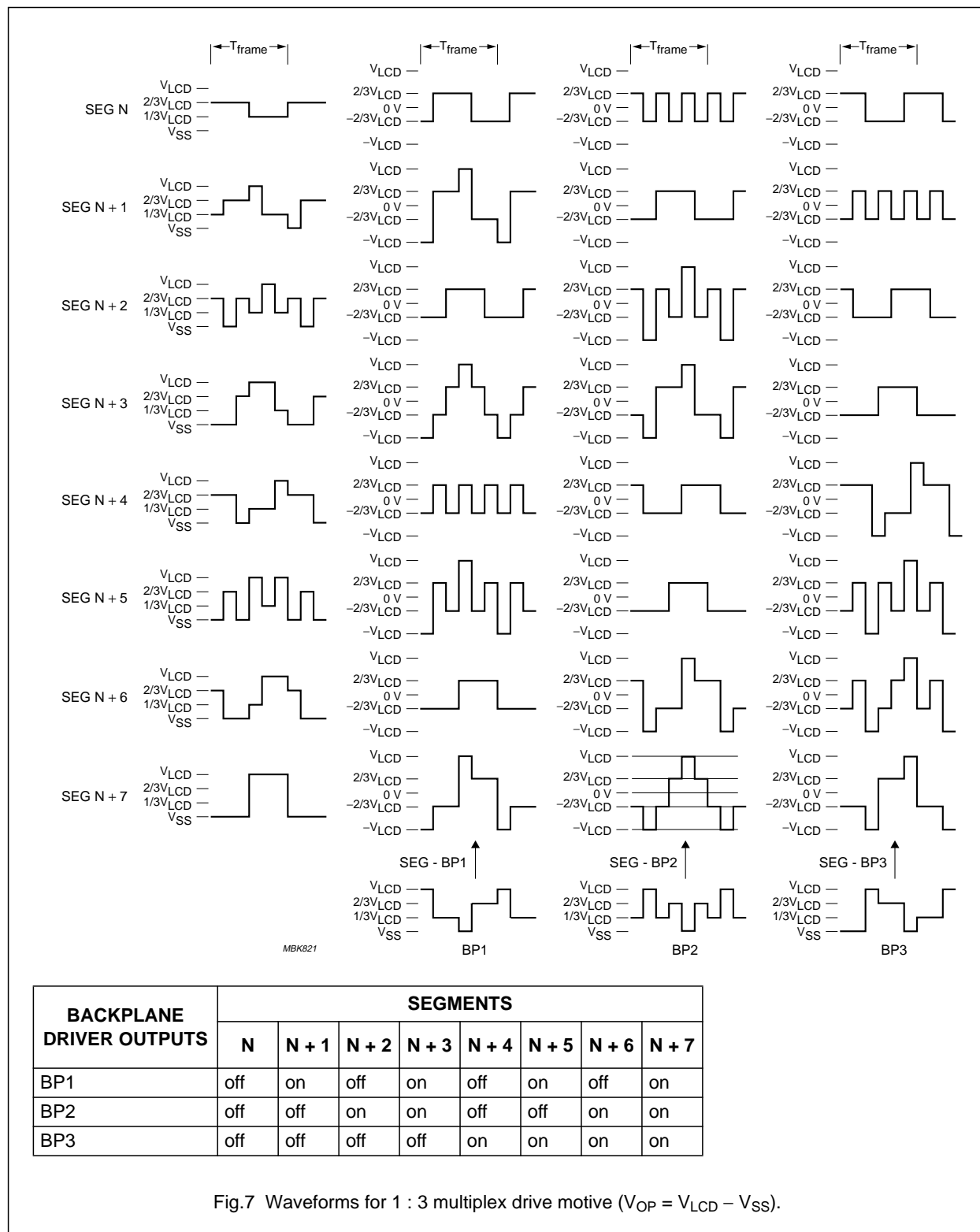

Fig.7 Waveforms for 1 : 3 multiplex drive motive ($V_{OP} = V_{LCD} - V_{SS}$).

LCD driver for low multiplex rates

OM4068

Oscillator

The internal logic and the multi-level LCD drive signals of the OM4068 are generated by the built-in RC oscillator. No external components are required.

In order to minimize radio frequency interference, the oscillator operates with symmetrical and slew-rate limited capacitor charge/discharge.

The oscillator runs continuously once the power down state after power-on has been left.

Interface to microprocessor unit: serial interface

A three-line bus structure enables serial unidirectional data transfer with microprocessors/microcontrollers. The three lines are a serial data input line (SDIN), a serial clock line (SCLK) and a data line enable (SCE). All inputs are CMOS compatible. These lines must always be in a defined state V_{SS} or V_{DD} . Floating inputs could damage the chip.

On the bus, one data bit is transferred during each clock pulse. The data on the SDIN line remains stable during the whole clock period. Data changes arrive with the falling edge of the serial clock SCLK (see Fig.8).

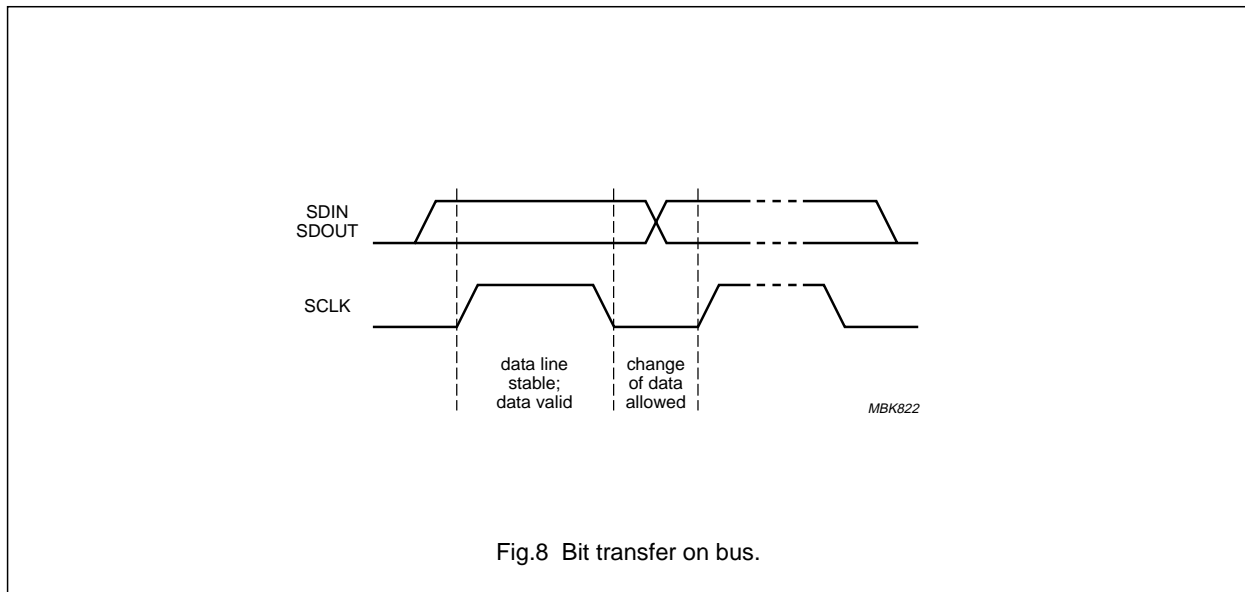
**Shift register**

Data present on the SDIN pin is shifted into a shift register with the rising edge of the serial clock SCLK in a synchronous manner. The shift register serves to transfer display information from the serial bus to the (display) latch while previous data is displayed.

The shift register is organized as three 32-bit shift registers. Depending on the display driving mode selected (see Table 3), one, two or three registers are used and cascaded resulting in a shift register length of 32, 64 or 96 bits. Figure 9 shows the shift register organization with the display data bits after a shift operation is completed. The shift sequence begins with data bit D32 and finishes with data bit D1. The correspondence between the data bit

numbers and the LCD display segments is shown in Table 4.

Data from the last stage of the register is supplied to the SDOUT pin to allow serial cascading of the OM4068 with other peripheral devices. Depending on the display driving mode selected, SDOUT corresponds to bit 32, 64 or 96 of the register (see Fig.10). Data on the SDOUT pin is shifted out with the falling edge of the SCLK clock. SDOUT is therefore delayed by $\frac{1}{2}$ SCLK cycle before it is applied to the SDIN pin of the next IC in the serial chain (see Fig.8).

The clock enable SCE signal must be HIGH in order to enable the shift operation. SDOUT output is latched with the last data after SCE returned to HIGH (shift operation terminated).

SDOUT is in 3-state mode when SCE is LOW.

LCD driver for low multiplex rates

OM4068

Display latch

The 96-bit display latch holds the display data while the corresponding multiplex signals are generated. There is a one-to-one relationship between the data in the display latch and the LCD segment outputs. An LCD segment is activated when the corresponding data bit in the display latch is HIGH.

Display latches are in HOLD mode (SCE HIGH) during the shift operation to maintain the display data constant.

Data are latched into the display latch with the internal frame clock. Thus there is a delay of up to one half frame before new data are latched after signal SCE returns to zero.

Timing

The timing of the OM4068 organizes the internal data flow of the device. This includes the transfer of display data from the shift register to the display segments outputs.

The timing also generates the LCD frame frequency which is derived from the clock frequency generated in the internal clock generator:

$$f_{fr(LCD)} = \frac{f_{osc}}{2400}$$

Shift register configuration

Fig.9 Display data bit position in shift register.

LCD driver for low multiplex rates

OM4068

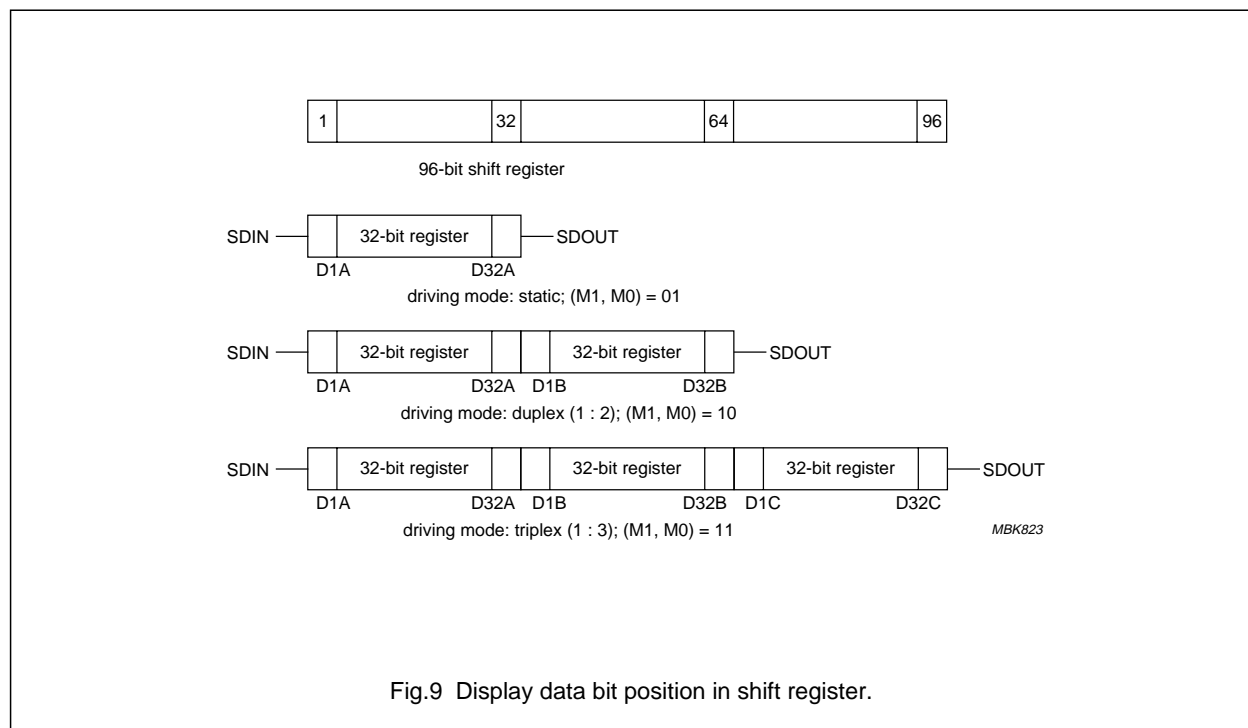
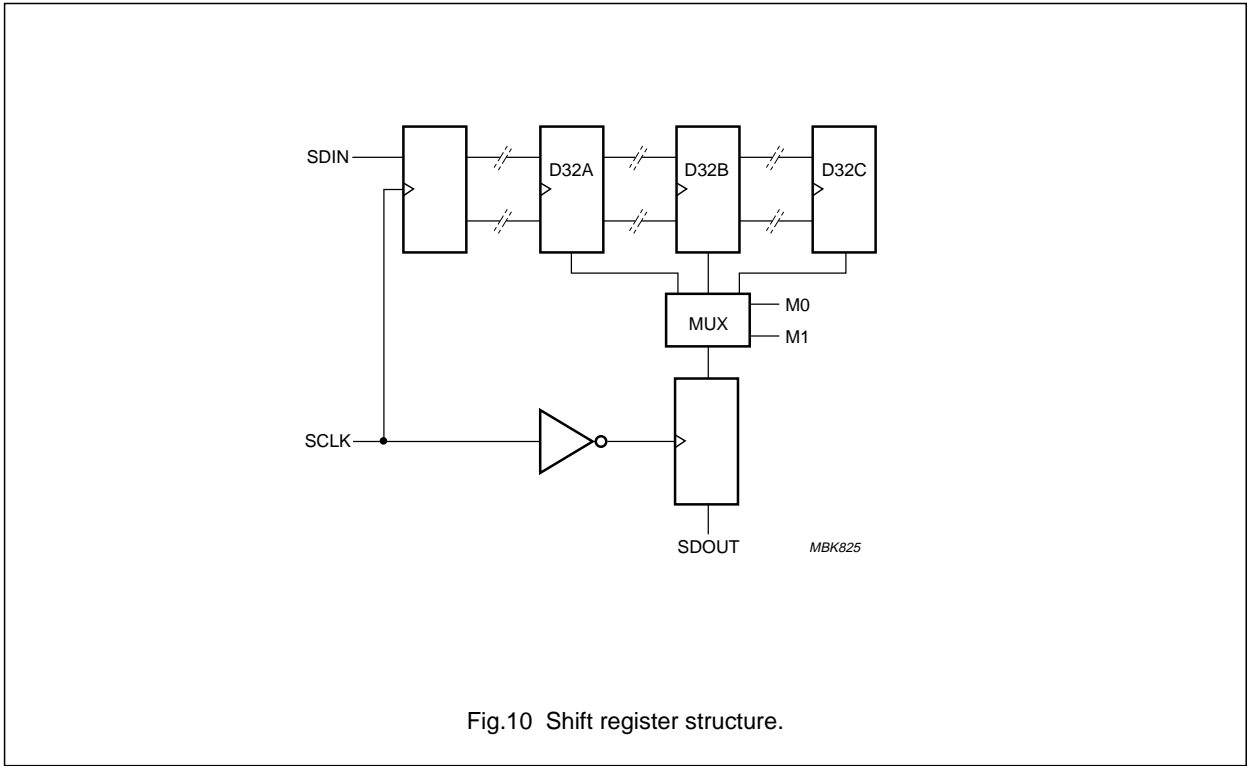

Fig.10 Shift register structure.

LCD driver for low multiplex rates

OM4068

Table 4 Relationships between data bit numbers and the LCD segment outputs

SEGMENT NUMBER	DRIVING MODE					
	STATIC	DUPLEX		TRIPLEX		
SEG1	D1A	D1A	D1B	D1A	D1B	D1C
SEG2	D2A	D2A	D2B	D2A	D2B	D2C
SEG3	D3A	D3A	D3B	D3A	D3B	D3C
SEG4	D4A	D4A	D4B	D4A	D4B	D4C
SEG5	D5A	D5A	D5B	D5A	D5B	D5C
SEG6	D6A	D6A	D6B	D6A	D6B	D6C
SEG7	D7A	D7A	D7B	D7A	D7B	D7C
SEG8	D8A	D8A	D8B	D8A	D8B	D8C
SEG9	D9A	D9A	D9B	D9A	D9B	D9C
SEG10	D10A	D10A	D10B	D10A	D10B	D10C
SEG11	D11A	D11A	D11B	D11A	D11B	D11C
SEG12	D12A	D12A	D12B	D12A	D12B	D12C
SEG13	D13A	D13A	D13B	D13A	D13B	D13C
SEG14	D14A	D14A	D14B	D14A	D14B	D14C
SEG15	D15A	D15A	D15B	D15A	D15B	D15C
SEG16	D16A	D16A	D16B	D16A	D16B	D16C
SEG17	D17A	D17A	D17B	D17A	D17B	D17C
SEG18	D18A	D18A	D18B	D18A	D18B	D18C
SEG19	D19A	D19A	D19B	D19A	D19B	D19C
SEG20	D20A	D20A	D20B	D20A	D20B	D20C
SEG21	D21A	D21A	D21B	D21A	D21B	D21C
SEG22	D22A	D22A	D22B	D22A	D22B	D22C
SEG23	D23A	D23A	D23B	D23A	D23B	D23C
SEG24	D24A	D24A	D24B	D24A	D24B	D24C
SEG25	D25A	D25A	D25B	D25A	D25B	D25C
SEG26	D26A	D26A	D26B	D26A	D26B	D26C
SEG27	D27A	D27A	D27B	D27A	D27B	D27C
SEG28	D28A	D28A	D28B	D28A	D28B	D28C
SEG29	D29A	D29A	D29B	D29A	D29B	D29C
SEG30	D30A	D30A	D30B	D30A	D30B	D30C
SEG31	D31A	D31A	D31B	D31A	D31B	D31C
SEG32	D32A	D32A	D32B	D32A	D32B	D32C

Segment outputs

The LCD drive section includes 32 segment outputs SEG1 to SEG32 which should be connected directly to the LCD. The segment output signals are generated in accordance with the multiplex backplane signals and with data in the display latch. When less than 32 segments are required the unused segment outputs should be left open-circuit.

LCD driver for low multiplex rates

OM4068

Backplane outputs

The LCD drive section includes three backplane outputs (BP1 to BP3) which should be connected directly to the LCD. The backplane output signals are generated in accordance with the selected LCD drive mode. If less than three backplane outputs are required the unused outputs should be left open-circuit. In 1 : 2 multiplex drive mode, BP3 is set to $\frac{1}{2}V_{LCD}$. In static drive mode BP3 and BP2 are set to V_{SS} .

LIMITING VALUES

In accordance with the Absolute Maximum Rating System (IEC 134).

SYMBOL	PARAMETER	CONDITIONS	MIN.	MAX.	UNIT
V_{DD}	supply voltage		-0.5	+6.5	V
V_{LCD}	LCD supply voltage		-0.5	+7.5	V
V_I	input voltage (any input)		-0.5	$V_{DD} + 0.5$	V
V_O	output voltage (BP1, BP2, BP3, S1 to S32 and V_{LCD})		-0.5	$V_{LCD} + 0.5$	V
I_I	DC input current		-10	+10	mA
I_O	DC output current		-10	+10	mA
I_{DD}, I_{SS}, I_{LCD}	V_{DD}, V_{SS} or V_{LCD} current		-50	+50	mA
$P_{tot(pack)}$	total power dissipation per package		-	500	mW
P/out	power dissipation per output		-	10	mW
T_{amb}	operating ambient temperature		-40	+105	°C
T_{stg}	storage temperature		-65	+150	°C
T_j	junction temperature		-	150	°C
V_{es}	electrostatic handling	note 1	-2000	+2000	V
		note 2	-150	+150	V

Notes

1. Equivalent to discharging a 100 pF capacitor via a 1.5 k Ω series resistor (human body model).
2. Equivalent to discharging a 200 pF capacitor via a 0.75 μ H series inductor (machine model).

HANDLING

Inputs and outputs are protected against electrostatic discharge in normal handling. However, to be totally safe, it is desirable to take normal precautions appropriate to handling MOS devices (see "Handling MOS Devices").

LCD driver for low multiplex rates

OM4068

DC CHARACTERISTICS

$V_{DD} = 2.5$ to 5.5 V; $V_{SS} = 0$ V; $V_{LCD} = 3.5$ to 6.5 V; $T_{amb} = -40$ to $+105$ °C; unless otherwise specified.

SYMBOL	PARAMETER	CONDITIONS	MIN.	TYP.	MAX.	UNIT
Supplies						
V_{DD}	supply voltage		$V_{SS} + 2.5$	–	5.5	V
V_{LCD}	LCD supply voltage		$V_{SS} + 3.5$	–	6.5	V
I_{DD}	supply current	power-down state; note 1	–	4	10	μ A
		normal mode; $f_{osc} = \text{intern}$; notes 2 and 3	–	12	25	μ A
I_{LCD}	V_{LCD} current	power-down state; note 1	–	–	1.5	μ A
		normal mode; $f_{osc} = \text{intern}$; notes 3 and 4	–	–	40	μ A
V_{POR}	power-on reset voltage level	note 5	0.8	1.25	1.6	V
Logic						
V_{IL}	LOW-level input voltage		V_{SS}	–	$0.3V_{DD}$	V
V_{IH}	HIGH-level input voltage		$0.7V_{DD}$	–	V_{DD}	V
I_{OL}	LOW-level output current (SDOUT)	$V_{OL} = 0.5$ V; $V_{DD} = 5$ V	1.0	–	–	mA
I_{OH}	HIGH-level output current (SDOUT)	$V_{OH} = V_{DD} - 0.5$ V; $V_{DD} = 5$ V	–	–	–1	mA
I_{pu}	pull-up current M1 and M0	$V_I = V_{SS}$	0.04	0.15	1	μ A
I_L	leakage current	$V_I = V_{DD}$ or V_{SS}	–1	–	+1	μ A
Segment and backplane outputs						
$R_{(o)seg}$	segment output resistance SEG1 to SEG32	note 6	–	15	40	k Ω
$R_{(o)back}$	backplane output resistance BP1 to BP3	note 6	–	15	40	k Ω
$V_{seg(bias)(tol)}$	bias tolerance SEG1 to SEG32	note 7	–100	0	+100	mV
$V_{back(bias)(tol)}$	bias tolerance BP1, BP2 and BP3	note 7	–100	0	+100	mV

Notes

1. Power-down state. After power-on the chip is in power-down state as long as the serial clock is not activated. During power-down all static currents are switched off except the power-on reset block.
2. Output SDOUT is open-circuit; inputs at V_{DD} or V_{SS} ; bus inactive.
3. Drive mode: static, duplex and triplex.
4. LCD outputs are open-circuit, $C_L = 50$ pF typical, inputs at V_{DD} or V_{SS} ; bus inactive.
5. Resets all logic when $V_{DD} < V_{POR}$.
6. Resistance of output terminal (S1 to S32 and BP1, BP2 and BP3) with a load current of 20 μ A; outputs measured one at a time.
7. LCD outputs open-circuits.

LCD driver for low multiplex rates

OM4068

AC CHARACTERISTICS

$V_{DD} = 2.5$ to 5.5 V; $V_{SS} = 0$ V; $V_{LCD} = 5.0$ V; $T_{amb} = -40$ to $+105$ °C; unless otherwise specified.

SYMBOL	PARAMETER	MIN.	TYP.	MAX.	UNIT
$f_{fr(LCD)}$	LCD frame frequency (internal clock)	50	84	175	Hz
f_{osc}	oscillator frequency (not available at any pin)	116	224	405	kHz
Bus timing characteristics: serial bus interface; note 1					
f_{SCLK}	SCLK clock frequency	0	–	2.1	MHz
t_{SCLKL}	SCLK clock LOW period	190	–	–	ns
t_{SCLKH}	SCLK clock HIGH period	190	–	–	ns
$t_{su(D)}$	data set-up time	100	–	–	ns
$t_{h(D)}$	data hold time	100	–	–	ns
t_r	SCLK, SDIN rise time	–	10	–	ns
t_f	SCLK, SDIN fall time	–	10	–	ns
$t_{su(en)}(SDEH-SCLKH)$	enable set-up time (SDE HIGH to SCLK HIGH)	250	–	–	ns
$t_{su(dis)}(SCLKL-SDEL)$	disable set-up time (SCLK LOW to SDE LOW)	250	–	–	ns
$t_{PHL}(SDOUT)$	SDOUT HIGH-to-LOW propagation delay	100	–	–	ns

Note

1. All timing values are valid within the operating supply voltage and ambient temperature range and are referenced to V_{IL} and V_{IH} with an input voltage swing of V_{SS} to V_{DD} .

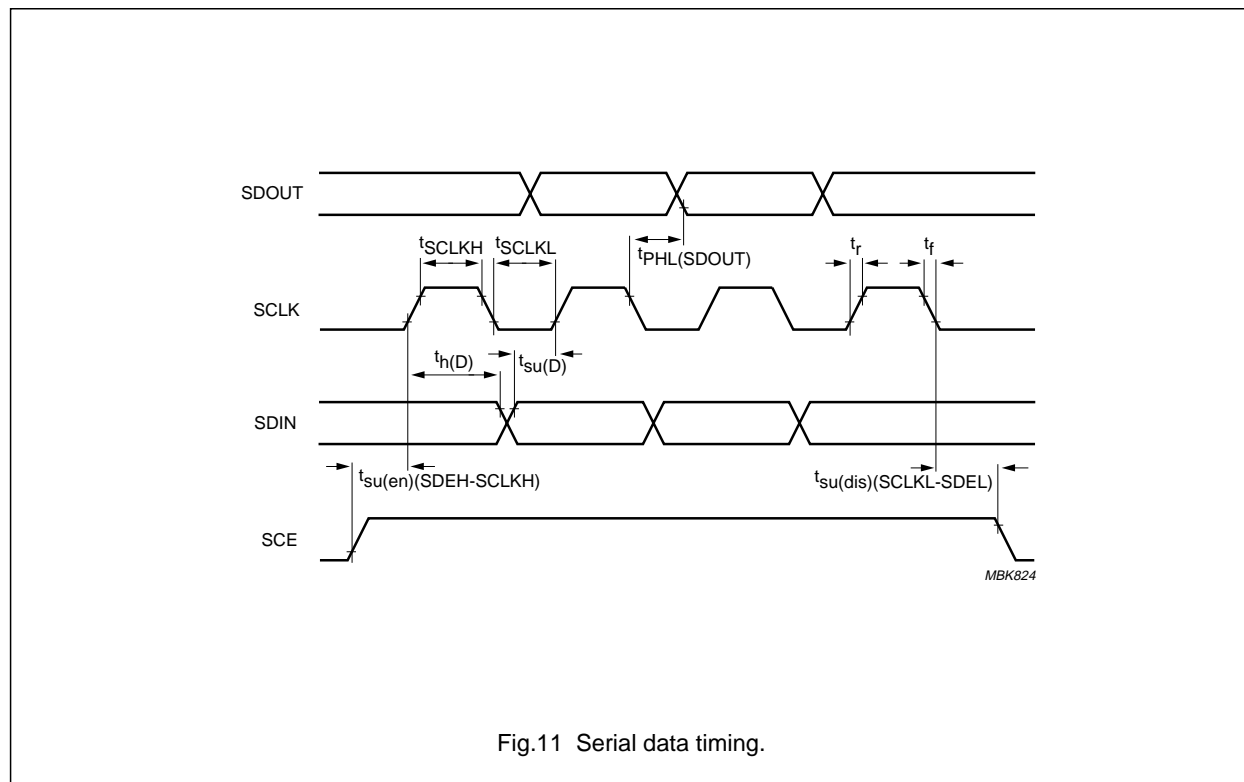

Fig.11 Serial data timing.

LCD driver for low multiplex rates

OM4068

Table 5 Bonding pad locations (dimensions in μm).
All x/y coordinates are referenced to bottom left corner of chip (see Fig.12).

SYMBOL	PAD	x	y
V _{DD}	5	43.100	970.500
V _{SS}	6	42.900	791.850
M0	7	43.100	661.750
M1	8	43.100	531.750
SDIN	9	43.100	401.750
SCLK	10	43.100	271.750
SCE	11	310.450	43.100
SDOUT	12	447.350	43.100
BP1	13	604.800	43.100
BP2	14	714.850	43.100
BP3	15	824.850	43.100
SEG1	16	924.850	43.100
SEG2	17	1024.850	43.100
SEG3	18	1124.850	43.100
SEG4	19	1224.850	43.100
SEG5	20	1327.250	43.100
SEG6	21	1432.450	43.100
SEG7	22	1532.650	43.100
SEG8	23	1783.600	293.850
SEG9	24	1783.600	458.850
SEG10	25	1783.600	603.850
SEG11	26	1783.600	703.850
SEG12	27	1783.600	803.850
SEG13	28	1783.600	903.850
SEG14	29	1783.600	1003.850
SEG15	30	1783.600	1103.850
SEG16	31	1783.600	1203.850
SEG17	32	1783.600	1323.850
SEG18	33	1783.600	1453.850
SEG19	34	1514.600	1711.100
SEG20	35	1370.550	1711.100
SEG21	36	1270.500	1711.100
SEG22	37	1170.500	1711.100
SEG23	38	1070.500	1711.100
SEG24	39	970.550	1711.100
SEG25	40	870.550	1711.100
SEG26	41	770.550	1711.100
SEG27	42	660.550	1711.100

SYMBOL	PAD	x	y
SEG28	43	550.550	1711.100
SEG29	44	430.550	1711.100
SEG30	1	300.550	1711.100
SEG31	2	43.100	1460.050
SEG32	3	43.100	1274.950
V _{LCD}	4	43.100	1158.700
Alignment marks			
C1	–	1769.6	1696.9
C2	–	1770.1	58.4
F	–	172.0	1705.2

LCD driver for low multiplex rates

OM4068

PACKAGE OUTLINES

QFP44: plastic quad flat package; 44 leads (lead length 1.3 mm); body 10 x 10 x 1.75 mm

SOT307-2

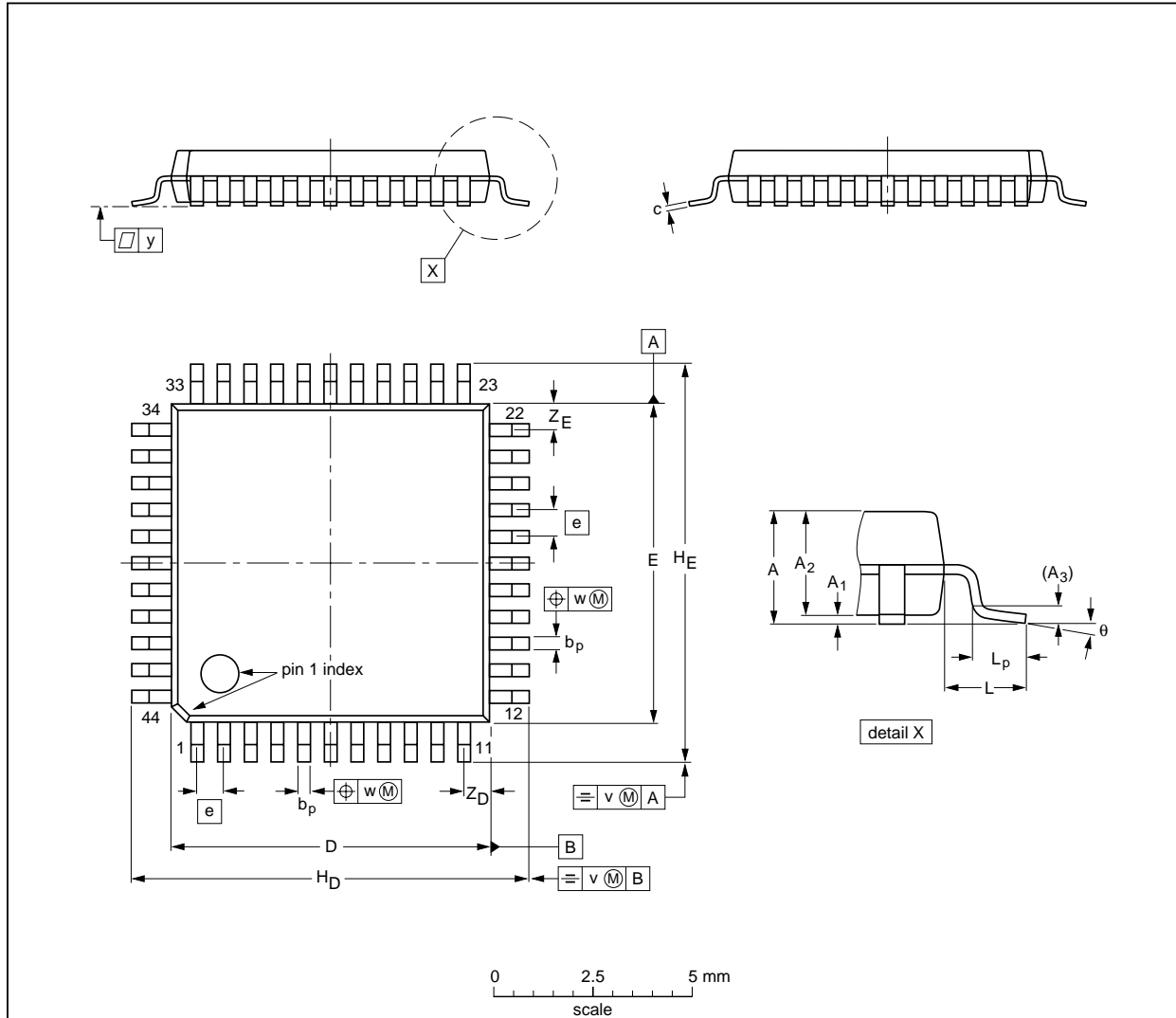

DIMENSIONS (mm are the original dimensions)

UNIT	A max.	A ₁	A ₂	A ₃	b _p	c	D ⁽¹⁾	E ⁽¹⁾	e	H _D	H _E	L	L _p	v	w	y	Z _D ⁽¹⁾	Z _E ⁽¹⁾	θ
mm	2.10	0.25 0.05	1.85 1.65	0.25	0.40 0.20	0.25 0.14	10.1 9.9	10.1 9.9	0.8	12.9 12.3	12.9 12.3	1.3	0.95 0.55	0.15	0.15	0.1	1.2 0.8	1.2 0.8	10° 0°

Note

1. Plastic or metal protrusions of 0.25 mm maximum per side are not included.

OUTLINE VERSION	REFERENCES				EUROPEAN PROJECTION	ISSUE DATE
	IEC	JEDEC	EIAJ			
SOT307-2						95-02-04 97-08-01

LCD driver for low multiplex rates

OM4068

DIP40: plastic dual in-line package; 40 leads (600 mil)

SOT129-1

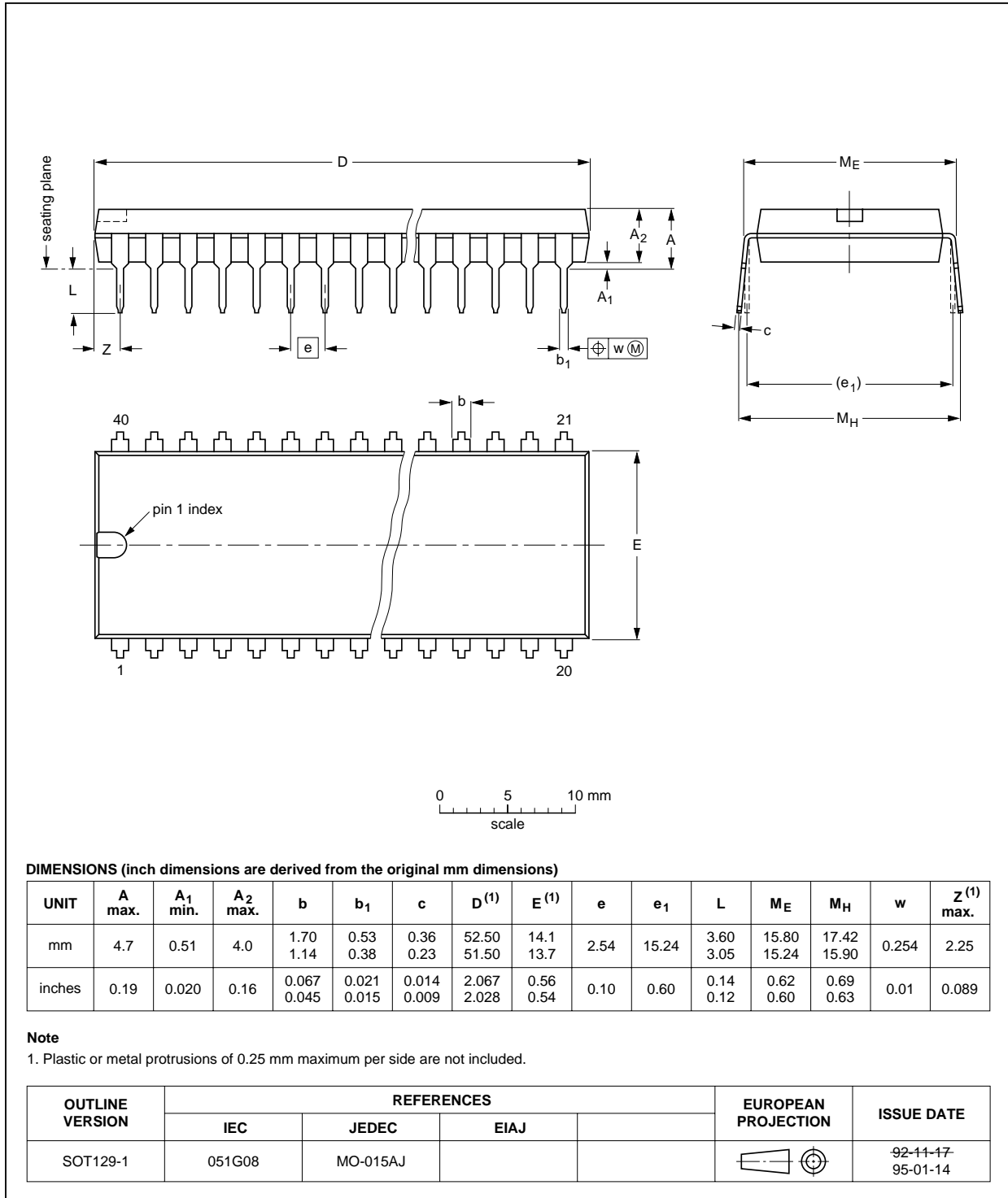

LCD driver for low multiplex rates

OM4068

SOLDERING**Introduction**

There is no soldering method that is ideal for all IC packages. Wave soldering is often preferred when through-hole and surface mounted components are mixed on one printed-circuit board. However, wave soldering is not always suitable for surface mounted ICs, or for printed-circuits with high population densities. In these situations reflow soldering is often used.

This text gives a very brief insight to a complex technology. A more in-depth account of soldering ICs can be found in our *"Data Handbook IC26; Integrated Circuit Packages"* (order code 9398 652 90011).

DIP**SOLDERING BY DIPPING OR BY WAVE**

The maximum permissible temperature of the solder is 260 °C; solder at this temperature must not be in contact with the joint for more than 5 seconds. The total contact time of successive solder waves must not exceed 5 seconds.

The device may be mounted up to the seating plane, but the temperature of the plastic body must not exceed the specified maximum storage temperature ($T_{stg\ max}$). If the printed-circuit board has been pre-heated, forced cooling may be necessary immediately after soldering to keep the temperature within the permissible limit.

REPAIRING SOLDERED JOINTS

Apply a low voltage soldering iron (less than 24 V) to the lead(s) of the package, below the seating plane or not more than 2 mm above it. If the temperature of the soldering iron bit is less than 300 °C it may remain in contact for up to 10 seconds. If the bit temperature is between 300 and 400 °C, contact may be up to 5 seconds.

QFP**REFLOW SOLDERING**

Reflow soldering techniques are suitable for all QFP packages.

The choice of heating method may be influenced by larger plastic QFP packages (44 leads, or more). If infrared or vapour phase heating is used and the large packages are not absolutely dry (less than 0.1% moisture content by weight), vaporization of the small amount of moisture in them can cause cracking of the plastic body. For details, refer to the Drypack information in the *"Data Handbook IC26; Integrated Circuit Packages; Section: Packing Methods"*.

Reflow soldering requires solder paste (a suspension of fine solder particles, flux and binding agent) to be applied to the printed-circuit board by screen printing, stencilling or pressure-syringe dispensing before package placement.

Several methods exist for reflowing; for example, infrared/convection heating in a conveyor type oven. Throughput times (preheating, soldering and cooling) vary between 50 and 300 seconds depending on heating method. Typical reflow peak temperatures range from 215 to 250 °C.

WAVE SOLDERING

Wave soldering is **not** recommended for QFP packages. This is because of the likelihood of solder bridging due to closely-spaced leads and the possibility of incomplete solder penetration in multi-lead devices.

CAUTION

Wave soldering is NOT applicable for all QFP packages with a pitch (e) equal or less than 0.5 mm.

If wave soldering cannot be avoided, for QFP packages with a pitch (e) larger than 0.5 mm, the following conditions must be observed:

- **A double-wave (a turbulent wave with high upward pressure followed by a smooth laminar wave) soldering technique should be used.**
- **The footprint must be at an angle of 45° to the board direction and must incorporate solder thieves downstream and at the side corners.**

LCD driver for low multiplex rates

OM4068

During placement and before soldering, the package must be fixed with a droplet of adhesive. The adhesive can be applied by screen printing, pin transfer or syringe dispensing. The package can be soldered after the adhesive is cured.

Maximum permissible solder temperature is 260 °C, and maximum duration of package immersion in solder is 10 seconds, if cooled to less than 150 °C within 6 seconds. Typical dwell time is 4 seconds at 250 °C.

A mildly-activated flux will eliminate the need for removal of corrosive residues in most applications.

REPAIRING SOLDERED JOINTS

Fix the component by first soldering two diagonally-opposite end leads. Use only a low voltage soldering iron (less than 24 V) applied to the flat part of the lead. Contact time must be limited to 10 seconds at up to 300 °C. When using a dedicated tool, all other leads can be soldered in one operation within 2 to 5 seconds between 270 and 320 °C.

DEFINITIONS

Data sheet status	
Objective specification	This data sheet contains target or goal specifications for product development.
Preliminary specification	This data sheet contains preliminary data; supplementary data may be published later.
Product specification	This data sheet contains final product specifications.
Limiting values	
Limiting values given are in accordance with the Absolute Maximum Rating System (IEC 134). Stress above one or more of the limiting values may cause permanent damage to the device. These are stress ratings only and operation of the device at these or at any other conditions above those given in the Characteristics sections of the specification is not implied. Exposure to limiting values for extended periods may affect device reliability.	
Application information	
Where application information is given, it is advisory and does not form part of the specification.	

LIFE SUPPORT APPLICATIONS

These products are not designed for use in life support appliances, devices, or systems where malfunction of these products can reasonably be expected to result in personal injury. Philips customers using or selling these products for use in such applications do so at their own risk and agree to fully indemnify Philips for any damages resulting from such improper use or sale.

LCD driver for low multiplex rates

OM4068

NOTES

LCD driver for low multiplex rates

OM4068

NOTES

Philips Semiconductors – a worldwide company

Argentina: see South America

Australia: 34 Waterloo Road, NORTH RYDE, NSW 2113,
Tel. +61 2 9805 4455, Fax. +61 2 9805 4466

Austria: Computerstr. 6, A-1101 WIEN, P.O. Box 213, Tel. +43 160 1010,
Fax. +43 160 101 1210

Belarus: Hotel Minsk Business Center, Bld. 3, r. 1211, Volodarski Str. 6,
220050 MINSK, Tel. +375 172 200 733, Fax. +375 172 200 773

Belgium: see The Netherlands

Brazil: see South America

Bulgaria: Philips Bulgaria Ltd., Energoproject, 15th floor,
51 James Bouchier Blvd., 1407 SOFIA,
Tel. +359 2 689 211, Fax. +359 2 689 102

Canada: PHILIPS SEMICONDUCTORS/COMPONENTS,
Tel. +1 800 234 7381

China/Hong Kong: 501 Hong Kong Industrial Technology Centre,
72 Tat Chee Avenue, Kowloon Tong, HONG KONG,
Tel. +852 2319 7888, Fax. +852 2319 7700

Colombia: see South America

Czech Republic: see Austria

Denmark: Prags Boulevard 80, PB 1919, DK-2300 COPENHAGEN S,
Tel. +45 32 88 2636, Fax. +45 31 57 0044

Finland: Sinikalliontie 3, FIN-02630 ESPOO,
Tel. +358 9 615800, Fax. +358 9 61580920

France: 51 Rue Carnot, BP317, 92156 SURESNES Cedex,
Tel. +33 1 40 99 6161, Fax. +33 1 40 99 6427

Germany: Hammerbrookstraße 69, D-20097 HAMBURG,
Tel. +49 40 23 53 60, Fax. +49 40 23 536 300

Greece: No. 15, 25th March Street, GR 17778 TAVROS/ATHENS,
Tel. +30 1 4894 339/239, Fax. +30 1 4814 240

Hungary: see Austria

India: Philips INDIA Ltd, Band Box Building, 2nd floor,
254-D, Dr. Annie Besant Road, Worli, MUMBAI 400 025,
Tel. +91 22 493 8541, Fax. +91 22 493 0966

Indonesia: PT Philips Development Corporation, Semiconductors Division,
Gedung Philips, Jl. Buncit Raya Kav.99-100, JAKARTA 12510,
Tel. +62 21 794 0040 ext. 2501, Fax. +62 21 794 0080

Ireland: Newstead, Clonskeagh, DUBLIN 14,
Tel. +353 1 7640 000, Fax. +353 1 7640 200

Israel: RAPAC Electronics, 7 Kehilat Saloniki St, PO Box 18053,
TEL AVIV 61180, Tel. +972 3 645 0444, Fax. +972 3 649 1007

Italy: PHILIPS SEMICONDUCTORS, Piazza IV Novembre 3,
20124 MILANO, Tel. +39 2 6752 2531, Fax. +39 2 6752 2557

Japan: Philips Bldg 13-37, Kohnan 2-chome, Minato-ku,
TOKYO 108-8507, Tel. +81 3 3740 5130, Fax. +81 3 3740 5077

Korea: Philips House, 260-199 Itaewon-dong, Yongsan-ku, SEOUL,
Tel. +82 2 709 1412, Fax. +82 2 709 1415

Malaysia: No. 76 Jalan Universiti, 46200 PETALING JAYA, SELANGOR,
Tel. +60 3 750 5214, Fax. +60 3 757 4880

Mexico: 5900 Gateway East, Suite 200, EL PASO, TEXAS 79905,
Tel. +9-5 800 234 7381

Middle East: see Italy

Netherlands: Postbus 90050, 5600 PB EINDHOVEN, Bldg. VB,
Tel. +31 40 27 82785, Fax. +31 40 27 88399

New Zealand: 2 Wagener Place, C.P.O. Box 1041, AUCKLAND,
Tel. +64 9 849 4160, Fax. +64 9 849 7811

Norway: Box 1, Manglerud 0612, OSLO,
Tel. +47 22 74 8000, Fax. +47 22 74 8341

Pakistan: see Singapore

Philippines: Philips Semiconductors Philippines Inc.,
106 Valero St. Salcedo Village, P.O. Box 2108 MCC, MAKATI,
Metro MANILA, Tel. +63 2 816 6380, Fax. +63 2 817 3474

Poland: Ul. Lukiska 10, PL 04-123 WARSZAWA,
Tel. +48 22 612 2831, Fax. +48 22 612 2327

Portugal: see Spain

Romania: see Italy

Russia: Philips Russia, Ul. Usatcheva 35A, 119048 MOSCOW,
Tel. +7 095 755 6918, Fax. +7 095 755 6919

Singapore: Lorong 1, Toa Payoh, SINGAPORE 319762,
Tel. +65 350 2538, Fax. +65 251 6500

Slovakia: see Austria

Slovenia: see Italy

South Africa: S.A. PHILIPS Pty Ltd., 195-215 Main Road Martindale,
2092 JOHANNESBURG, P.O. Box 7430 Johannesburg 2000,
Tel. +27 11 470 5911, Fax. +27 11 470 5494

South America: Al. Vicente Pinzon, 173, 6th floor,
04547-130 SÃO PAULO, SP, Brazil,
Tel. +55 11 821 2333, Fax. +55 11 821 2382

Spain: Balmes 22, 08007 BARCELONA,
Tel. +34 93 301 6312, Fax. +34 93 301 4107

Sweden: Kottbygatan 7, Akalla, S-16485 STOCKHOLM,
Tel. +46 8 5985 2000, Fax. +46 8 5985 2745

Switzerland: Allmendstrasse 140, CH-8027 ZÜRICH,
Tel. +41 1 488 2741 Fax. +41 1 488 3263

Taiwan: Philips Semiconductors, 6F, No. 96, Chien Kuo N. Rd., Sec. 1,
TAIPEI, Taiwan Tel. +886 2 2134 2865, Fax. +886 2 2134 2874

Thailand: PHILIPS ELECTRONICS (THAILAND) Ltd.,
209/2 Sanpavuth-Bangna Road Prakanong, BANGKOK 10260,
Tel. +66 2 745 4090, Fax. +66 2 398 0793

Turkey: Talatpasa Cad. No. 5, 80640 GÜLTEPE/ISTANBUL,
Tel. +90 212 279 2770, Fax. +90 212 282 6707

Ukraine: PHILIPS UKRAINE, 4 Patrice Lumumba str., Building B, Floor 7,
252042 KIEV, Tel. +380 44 264 2776, Fax. +380 44 268 0461

United Kingdom: Philips Semiconductors Ltd., 276 Bath Road, Hayes,
MIDDLESEX UB3 5BX, Tel. +44 181 730 5000, Fax. +44 181 754 8421

United States: 811 East Arques Avenue, SUNNYVALE, CA 94088-3409,
Tel. +1 800 234 7381

Uruguay: see South America

Vietnam: see Singapore

Yugoslavia: PHILIPS, Trg N. Pasicca 5/v, 11000 BEOGRAD,
Tel. +381 11 625 344, Fax. +381 11 635 777

For all other countries apply to: Philips Semiconductors,
International Marketing & Sales Communications, Building BE-p, P.O. Box 218,
5600 MD EINDHOVEN, The Netherlands, Fax. +31 40 27 24825

Internet: <http://www.semiconductors.philips.com>

© Philips Electronics N.V. 1998

SCA60

All rights are reserved. Reproduction in whole or in part is prohibited without the prior written consent of the copyright owner.

The information presented in this document does not form part of any quotation or contract, is believed to be accurate and reliable and may be changed without notice. No liability will be accepted by the publisher for any consequence of its use. Publication thereof does not convey nor imply any license under patent- or other industrial or intellectual property rights.

Printed in The Netherlands

415106/1200/01/pp28

Date of release: 1998 Jun 18

Document order number: 9397 750 03802

Let's make things better.

**Philips
Semiconductors**



PHILIPS