



True RMS-to-DC Converters

MX536A/MX636

General Description

The MX536A and MX636 are true RMS-to-DC converters. They feature low power and are designed to accept low-level input signals from 0 to $7V_{RMS}$ for the MX536A and 0 to $200mV_{RMS}$ for the MX636. Both devices accept complex input waveforms containing AC and DC components. They can be operated from either a single supply or dual supplies. Both devices draw less than 1mA of quiescent supply current, making them ideal for battery-powered applications.

Input and output offset, positive and negative waveform symmetry (DC reversal), and full-scale accuracy are laser trimmed, so that no external trims are required to achieve full rated accuracy.

Applications

- Digital Multimeters
- Battery-Powered Instruments
- Panel Meters
- Process Control

Pin Configurations

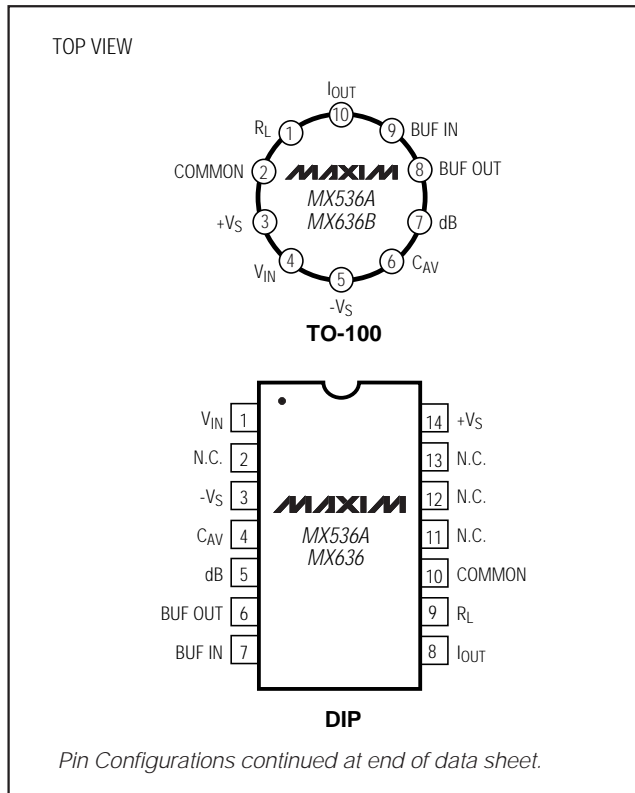

Features

- ◆ True RMS-to-DC Conversion
- ◆ Computes RMS of AC and DC Signals
- ◆ Wide Response:
 - 2MHz Bandwidth for $V_{RMS} > 1V$ (MX536A)
 - 1MHz Bandwidth for $V_{RMS} > 100mV$ (MX636)
- ◆ Auxiliary dB Output: 60dB Range (MX536A)
50dB Range (MX636)
- ◆ Single- or Dual-Supply Operation
- ◆ Low Power: 1.2mA typ (MX536A)
800 μ A typ (MX636)

Ordering Information

PART	TEMP. RANGE	PIN-PACKAGE
MX536AJC/D	0°C to +70°C	Dice**
MX536AJCWE	0°C to +70°C	16 Wide SO
MX536AJD	0°C to +70°C	14 Ceramic
MX536AJH	0°C to +70°C	10 TO-100
MX536AJN	0°C to +70°C	14 Plastic DIP
MX536AJQ*	0°C to +70°C	14 CERDIP
MX536AKCWE	0°C to +70°C	16 Wide SO
MX536AKD	0°C to +70°C	14 Ceramic
MX536AKH	0°C to +70°C	10 TO-100
MX536AKN	0°C to +70°C	14 Plastic DIP
MX536AKQ*	0°C to +70°C	14 CERDIP
MX536ASD	-55°C to +125°C	14 Ceramic

Ordering Information continued at end of data sheet.

* Maxim reserves the right to ship ceramic packages in lieu of CERDIP packages.

** Dice are specified at $T_A = +25^\circ C$.

Typical Operating Circuits

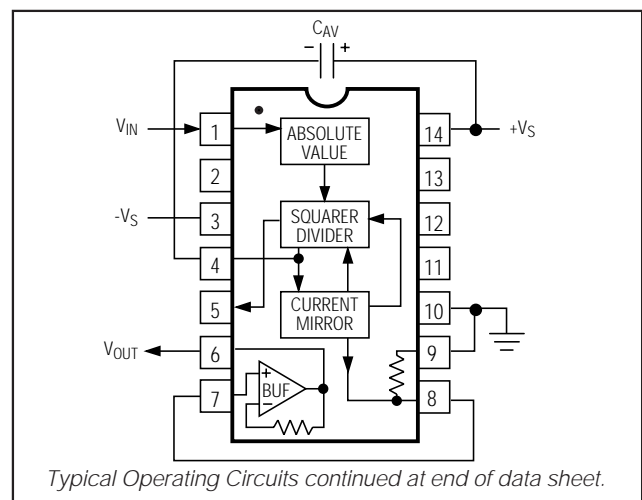

**For free samples & the latest literature: <http://www.maxim-ic.com>, or phone 1-800-998-8800.
For small orders, phone 408-737-7600 ext. 3468.**

True RMS-to-DC Converters

MX536A/MX636

ELECTRICAL CHARACTERISTICS—MX536A (continued)

($T_A = +25^\circ\text{C}$, $+V_S = +15\text{V}$, $-V_S = -15\text{V}$, unless otherwise noted.)

PARAMETER	CONDITIONS	MIN	TYP	MAX	UNITS	
INPUT CHARACTERISTICS						
Input Signal Range	$\pm 15\text{V}$ Supplies Continuous RMS Peak Transient	0 to 7			V_{RMS}	
					± 20	V_{PK}
	$\pm 5\text{V}$ Supplies Continuous RMS Peak Transient	0 to 2			V_{RMS}	
					± 7	V_{PK}
Safe Input	All Supplies				± 25	V_{PK}
Input Resistance		13.33	16.7	20.00	$\text{k}\Omega$	
Input Offset Voltage	MX536AJ, AS	0.8			± 2	mV
	MX536AK	0.5			± 1	
OUTPUT CHARACTERISTICS						
Offset Voltage	$T_A = +25^\circ\text{C}$	MX536AJ	± 1	± 2	mV	
		MX536AK	± 0.5	± 1		
		MX536AS	± 2			
	$T_A = T_{\text{MIN}}$ to T_{MAX}	MX536AJ, AK	± 0.1			mV/ $^\circ\text{C}$
		MX536AS	± 0.2			
	Supply Voltage	MX536AJ, AK	± 0.1			mV/V
MX536AS		± 0.2				
Output Voltage Swing	$\pm 15\text{V}$ Supplies	0 to 11	12.5		V	
	$\pm 5\text{V}$ Supplies	0 to 2				
Output Current	Source	5			mA	
	Sink	-130			μA	
Short Circuit Current		20			mA	
Output Resistance		0.5			Ω	
dB OUTPUT						
Error	$V_{\text{IN}} = 7\text{mV}$ to $7V_{\text{RMS}}$, $0\text{dB} = 1V_{\text{RMS}}$	MX536AJ	± 0.4	± 0.6	dB	
		MX536AK	± 0.2	± 0.3		
		MX536AS	± 0.5	± 0.6		
Scale Factor		-3			mV/dB	
Scale Factor TC (Uncompensated)		0.33			% of Reading/ $^\circ\text{C}$	
I_{REF}	$0\text{dB} = 1V_{\text{RMS}}$	5	20	80	μA	
I_{REF} Range		1	100		μA	
I_{OUT} TERMINAL						
I_{OUT} Scale Factor		40			$\mu\text{A}/V_{\text{RMS}}$	
I_{OUT} Scale Factor Tolerance		± 10 ± 20			%	
Output Resistance		20	25	30	$\text{k}\Omega$	
Voltage Compliance		- V_S to ($+V_S - 2.5$)			V	

True RMS-to-DC Converters

ELECTRICAL CHARACTERISTICS—MX536A (continued)

($T_A = +25^\circ\text{C}$, $+V_S = +15\text{V}$, $-V_S = -15\text{V}$, unless otherwise noted.)

PARAMETER	CONDITIONS	MIN	TYP	MAX	UNITS
BUFFER AMPLIFIER					
Input and Output Voltage Range		- V_S to ($+V_S - 2.5$)			V
Input Offset Voltage	$R_S = 25\text{k}\Omega$		± 0.5	± 4	mV
Input Bias Current			20	300	nA
Input Resistance			10^8		Ω
Output Current	Source	+5			mA
	Sink	-130			μA
Short-Circuit Current			20		mA
Small-Signal Bandwidth			1		MHz
Slew Rate (Note 4)			5		V/ μs

ELECTRICAL CHARACTERISTICS—MX636

($T_A = +25^\circ\text{C}$, $+V_S = +3\text{V}$, $-V_S = -5\text{V}$, unless otherwise noted.)

PARAMETER	CONDITIONS		MIN	TYP	MAX	UNITS
Transfer Equation			$V_{\text{OUT}} = [\text{avg. } (V_{\text{IN}})^2]^{1/2}$			
Averaging Time Constant	Figure 3			25		ms/ $\mu\text{F } C_{\text{AV}}$
CONVERSION ACCURACY						
Total Error, Internal Trim (Notes 5, 6)	MX636J				$\pm 0.5 \pm 1.0$	mV $\pm\%$ of Reading
	MX636K				$\pm 0.2 \pm 0.5$	
Total Error vs. Temperature (0°C to $+70^\circ\text{C}$)	MX636J				$\pm 0.1 \pm 0.01$	mV $\pm\%$ of Reading/ $^\circ\text{C}$
	MX636K				$\pm 0.1 \pm 0.005$	
Total Error vs. Supply				$\pm 0.1 \pm 0.01$		mV $\pm\%$ of Reading/V
Total Error vs. DC Reversal	$V_{\text{IN}} = 200\text{mV}$	MX636J		± 0.2		$\pm\%$ of Reading
		MX636K		± 0.1		
Total Error, External Trim (Note 5)	MX636J				$\pm 0.3 \pm 0.1$	mV $\pm\%$ of Reading
	MX636K				$\pm 0.1 \pm 0.1$	
ERROR vs. CREST FACTOR (Note 3)						
Additional Error	Crest Factor 1 to 2			Specified Accuracy		$\pm\%$ of Reading
	Crest Factor = 3			-0.2		
	Crest Factor = 6			-0.5		
FREQUENCY RESPONSE (Notes 6, 8)						
Bandwidth for 1% Additional Error (0.09dB)	$V_{\text{IN}} = 10\text{mV}$			14		kHz
	$V_{\text{IN}} = 100\text{mV}$			90		
	$V_{\text{IN}} = 200\text{mV}$			130		
$\pm 3\text{dB}$ Bandwidth	$V_{\text{IN}} = 10\text{mV}$			100		kHz
	$V_{\text{IN}} = 100\text{mV}$			900		
	$V_{\text{IN}} = 200\text{mV}$			1.5		MHz

True RMS-to-DC Converters

MX536A/MX636

ELECTRICAL CHARACTERISTICS—MX636 (continued)

($T_A = +25^\circ\text{C}$, $+V_S = +3\text{V}$, $-V_S = -5\text{V}$, unless otherwise noted.)

PARAMETER	CONDITIONS		MIN	TYP	MAX	UNITS
INPUT CHARACTERISTICS						
Input Signal Range	Continuous RMS, All Supplies		0 to 200			mV _{RMS}
	Peak Transient	+3V, -5V Supplies	±2.8			V _{PK}
		±2.5V Supplies	±2			
		±5V Supplies	±5			
Safe Input	All Supplies	±12			V _{PK}	
Input Resistance			5.33	6.7	8.00	k Ω
Input Offset Voltage	MX636J		±0.5			mV
	MX636K		±0.2			
OUTPUT CHARACTERISTICS (Note 5)						
Offset Voltage	$T_A = +25^\circ\text{C}$	MX636J	±0.5			mV
		MX636K	±0.2			
	$T_A = T_{\text{MIN}}$ to T_{MAX}		±10			$\mu\text{V}/^\circ\text{C}$
With Supply Voltage		±0.1			mV/V	
Output Voltage Swing	+3V, -5V Supplies		0 to 1			V
	±5V to ±16.5V Supplies		0 to 1	1.4		
Output Resistance			8	10	12	k Ω
dB OUTPUT						
Error	$7\text{mV} \leq V_{\text{IN}} \leq 300\text{mV}$	MX636J	±0.3		±0.5	dB
		MX636K	±0.1		±0.2	
Scale Factor			-3			mV/dB
Scale Factor Tempco			+0.33			$\%/^\circ\text{C}$
			-0.033			dB/ $^\circ\text{C}$
I _{REF}	0dB = 1V _{RMS}		2	4	8	μA
I _{REF} Range			1		50	μA
I_{OUT} TERMINAL						
I _{OUT} Scale Factor			100			$\mu\text{A}/\text{V}_{\text{RMS}}$
I _{OUT} Scale Factor Tolerance			-20	±10	+20	%
Output Resistance			8	10	12	k Ω
Voltage Compliance			-V _S to (+V _S - 2.0)			V
BUFFER AMPLIFIER						
Input and Output Voltage Range			-V _S to (+V _S - 2)			V
Input Offset Voltage	R _S = 10k Ω	MX636J	±0.8		±2	mV
		MX636K	±0.5		±1	
Input Current			100	300		nA
Input Resistance			10 ⁸			Ω
Output Current	Source			+5		mA
	Sink			-130		μA
Short-Circuit Current			20			mA
Small-Signal Bandwidth			1			MHz
Slew Rate (Note 9)			5			V/ μs

True RMS-to-DC Converters

ELECTRICAL CHARACTERISTICS—MX636 (continued)

($T_A = +25^\circ\text{C}$, $+V_S = +3\text{V}$, $-V_S = -5\text{V}$, unless otherwise noted.)

PARAMETER	CONDITIONS	MIN	TYP	MAX	UNITS
POWER SUPPLY					
Rated Performance			+3/-5		V
Dual Supplies		+2/-2.5		±16.5	V
Single Supply		+5		+24	V
Quiescent Current (Note 10)			0.8	1	mA

Note 1: Accuracy is specified for 0 to $7V_{\text{RMS}}$, DC or 1kHz sine-wave input with the MX536A connected as in Figure 2.

Note 2: Error vs. crest factor is specified as an additional error for $1V_{\text{RMS}}$ rectangular pulse stream, pulse width = 200 μs .

Note 3: Input voltages are expressed in volts RMS, and error as % of reading.

Note 4: With 2k Ω external pull-down resistor.

Note 5: Accuracy is specified for 0 to 200mV, DC or 1kHz sine-wave input. Accuracy is degraded at higher RMS signal levels.

Note 6: Measured at pin 8 of DIP and SO (I_{OUT}), with pin 9 tied to COMMON.

Note 7: Error vs. crest factor is specified as an additional error for 200mV $_{\text{RMS}}$ rectangular pulse input, pulse width = 200 μs .

Note 8: Input voltages are expressed in volts RMS.

Note 9: With 10k Ω external pull-down resistor from pin 6 (BUF OUT) to $-V_S$.

Note 10: With BUF input tied to COMMON.

Detailed Description

The MX536A/MX636 uses an implicit method of RMS computation that overcomes the dynamic range as well as other limitations inherent in a straightforward computation of the RMS. The actual computation performed by the MX536A/MX636 follows the equation:

$$V_{\text{RMS}} = \text{Avg.} [V_{\text{IN}}^2/V_{\text{RMS}}]$$

The input voltage, V_{IN} , applied to the MX536A/MX636 is processed by an absolute-value/voltage to current converter that produces a unipolar current I_1 (Figure 1). This current drives one input of a squarer/divider that produces a current I_4 that has a transfer function:

$$I_4 = \frac{I_1^2}{I_3}$$

The current I_4 drives the internal current mirror through a lowpass filter formed by R_1 and an external capacitor, C_{AV} . As long as the time constant of this filter is greater than the longest period of the input signal, I_4 is averaged. The current mirror returns a current, I_3 , to the square/divider to complete the circuit. The current I_4 is then a function of the average of (I_1^2/I_4) , which is equal to $I_{1\text{RMS}}$.

The current mirror also produces a $2 \cdot I_4$ output current, I_{OUT} , that can be used directly or converted to a voltage using resistor R_2 and the internal buffer to provide a low-impedance voltage output. The transfer function for the MX536A/MX636 is:

$$V_{\text{OUT}} = 2 \cdot R_2 \cdot I_{\text{RMS}} = V_{\text{IN}}$$

The dB output is obtained by the voltage at the emitter of Q3, which is proportional to the $-\log V_{\text{IN}}$. The emitter follower Q5 buffers and level shifts this voltage so that the dB output is zero when the externally set emitter current for Q5 approximates I_3 .

Standard Connection (Figure 2)

The standard RMS connection requires only one external component, C_{AV} . In this configuration the MX536A/MX636 measures the RMS of the AC and DC levels present at the input, but shows an error for low-frequency inputs as a function of the C_{AV} filter capacitor. Figure 3 gives practical values of C_{AV} for various values of averaging error over frequency for the standard RMS connections (no post filtering). If a 3 μF capacitor is chosen, the additional error at 100Hz will be 1%. If the DC error can be rejected, a capacitor should be connected in series with the input, as would typically be the case in single-supply operation.

The input and output signal ranges are a function of the supply voltages. Refer to the electrical characteristics for guaranteed performance. The buffer amplifier can be used either for lowering the output impedance of the circuit, or for other applications such as buffering high-impedance input signals. The MX536A/MX636 can be used in current output mode by disconnecting the internal load resistor, R_L , from ground. The current output is available at pin 8 (pin 10 on the "H" package) with a nominal scale of 40 $\mu\text{A}/V_{\text{RMS}}$ input for the MX536A and 100 $\mu\text{A}/V_{\text{RMS}}$ input for the MX636. The output is positive.

True RMS-to-DC Converters

MX536A/MX636

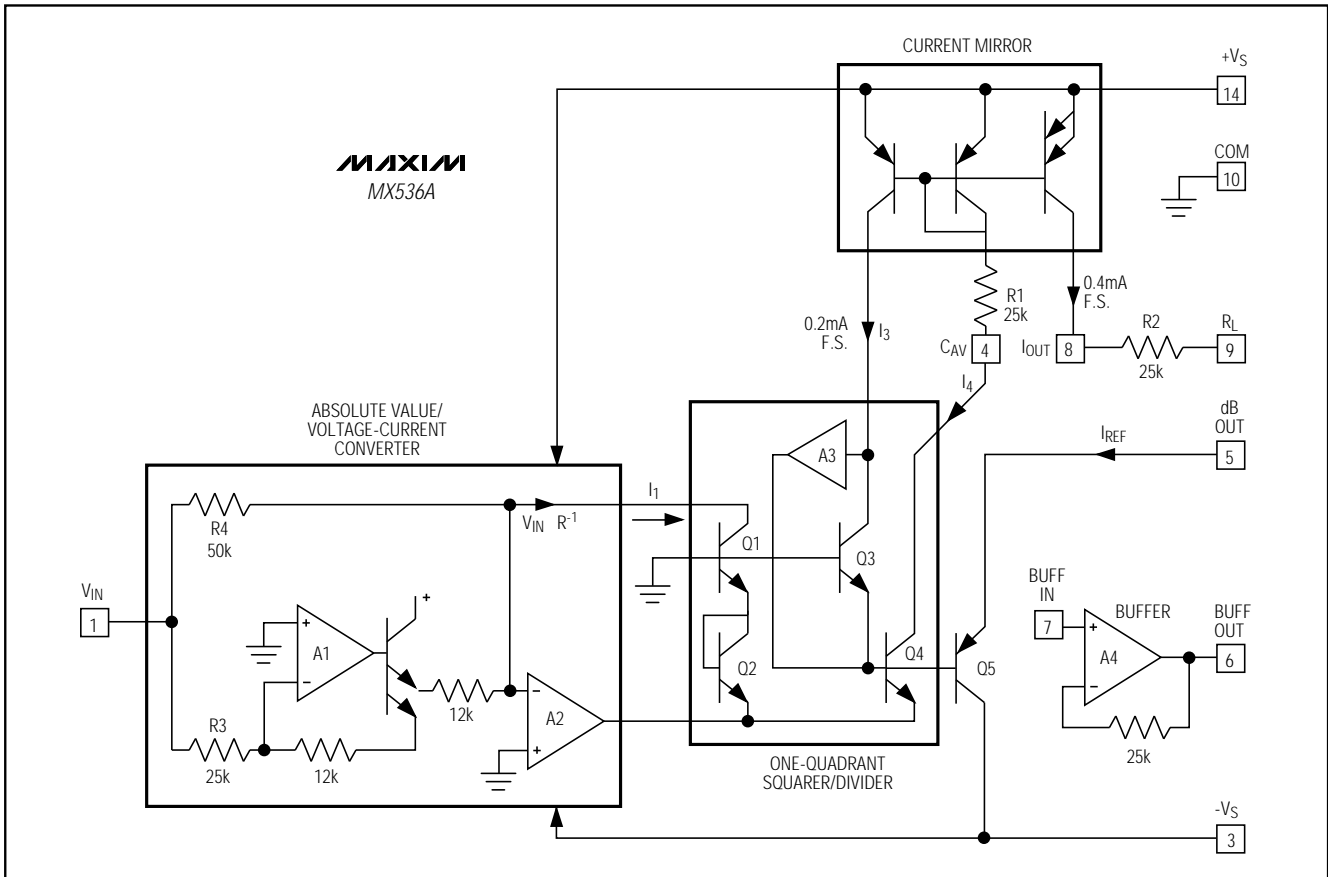

Figure 1. MX536A Simplified Schematic

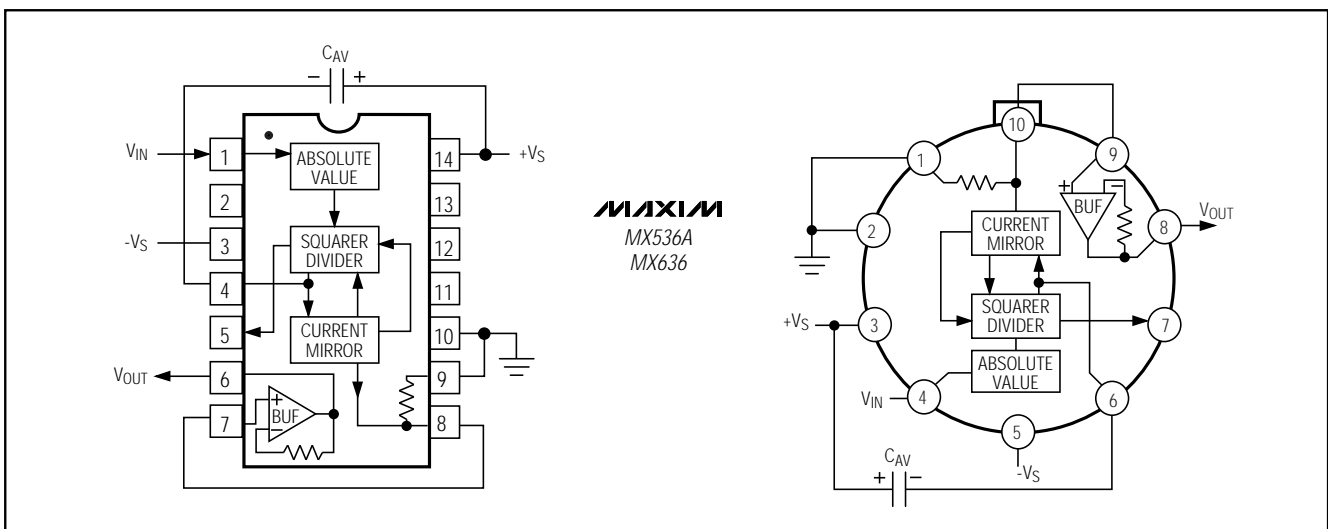

Figure 2. MX536A/MX636 Standard RMS Connection

True RMS-to-DC Converters

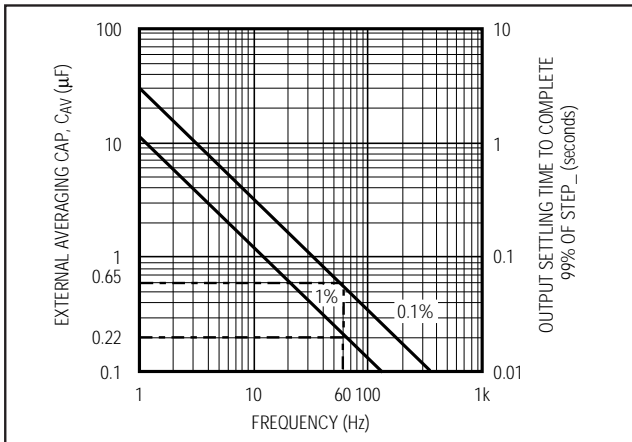

Figure 3. Lower Frequency for Stated % of Reading Error and Settling Time for Circuit shown in Figure 2

High-Accuracy Adjustments

The accuracy of the MX536A/MX636 can be improved by the addition of external trims as shown in Figure 4. R4 trims the offset. The input should be grounded and R4 adjusted to give zero volts output from pin 6. R1 is trimmed to give the correct value for either a calibrated DC input or a calibrated AC signal. For example: 200mV DC input or a calibrated AC signal. For example: 200mV DC input should give 200mV DC output; a $\pm 200\text{mV}$ peak-to-peak sine-wave should give 141mV DC output.

Single-Supply Operation

Both the MX536A and the MX636 can be used with a single supply down to +5V (Figure 5). The major limitation of this connection is that only AC signals can be measured, since the differential input stage must be biased off ground for proper operation. The load resistor is necessary to provide output sink current. The input signal is coupled through C2 and the value chosen so that the desired low-frequency break point is obtained with the input resistance of 16.7k Ω for the MX536A and 6.7k Ω for the MX636.

Figure 5 shows how to bias pin 10 within the range of the supply voltage (pin 2 on "H" packages). It is critical that no extraneous signals are coupled into this pin. A capacitor connected between pin 10 and ground is recommended. The common pin requires less than 5 μA of input current, and if the current flowing through resistors R1 and R2 is chosen to be approximately 10 times the common pin current, or 50 μA , the resistor values can easily be calculated.

Choosing the Averaging Time Constant

Both the MX536A and MX636 compute the RMS value of AC and DC signals. At low frequencies and DC, the output tracks the input exactly; at higher frequencies,

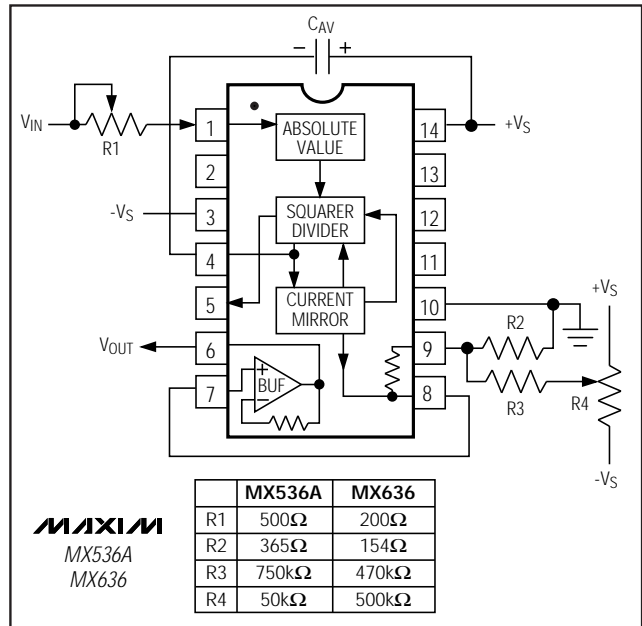

Figure 4. Optional External Gain and Output Offset Trims

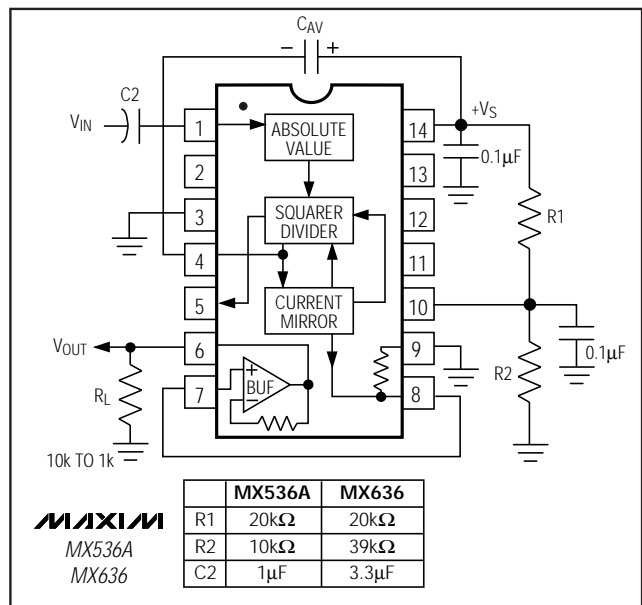

Figure 5. Single-Supply Operation

the average output approaches the RMS value of the input signal. The actual output differs from the ideal by an average (or DC) error plus some amount of ripple.

The DC error term is a function of the value of C_{AV} and the input signal frequency. The output ripple is inverse-

True RMS-to-DC Converters

MX536A/MX636

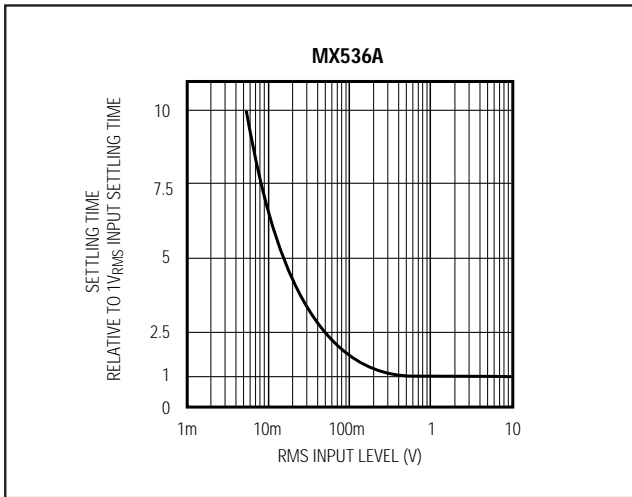

Figure 6a. MX536A Settling Time vs. Input Level

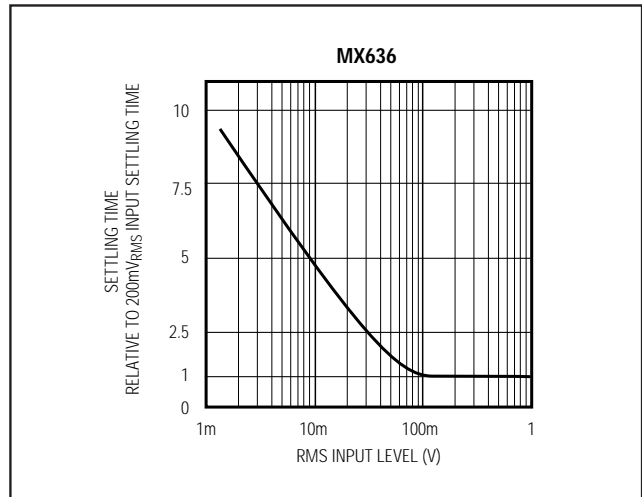

Figure 6b. MX636 Settling Time vs. Input Level

ly proportional to the value of C_{AV} . Waveforms with high crest factors, such as a pulse train with low duty cycle, should have an average time constant chosen to be at least ten times the signal period.

Using a large value of C_{AV} to remove the output ripple increases the settling time for a step change in the input signal level. Figure 3 shows the relationship between C_{AV} and settling time, where 115ms settling equals $1\mu\text{F}$ of C_{AV} . The settling time, or time for the RMS converter to settle to within a given percent of the change in RMS level, is set by the averaging time constant, which varies approximately 2:1 between increasing and decreasing input signals. For example, increasing input signals require 2.3 time constants to settle to within 1%, and 4.6 time constants for decreasing signals levels.

In addition, the settling time also varies with input signal levels, increasing as the input signal is reduced, and decreasing as the input is increased as shown in Figures 6a and 6b.

Using Post Filters

A post filter allows a smaller value of C_{AV} , and reduces ripple and improves the overall settling time. The value of C_{AV} should be just large enough to give the maximum DC error at the lowest frequency of interest. The post filter is used to remove excess output ripple. Figures 7, 8, and 9 give recommended filter connections and values for both the MX536A and MX636. Table 1 lists the number of time constants required for the RMS section to settle to within different percentages of the final value for a step change in the input signal.

Table 1. Number of RC Time Constants (τ) Required for MX536A/MX636 RMS Converters to Settle to Within Stated % of Final Value

PARAMETERS		FOR INCREASING AMPLITUDES	FOR DECREASING AMPLITUDES
Basic Formulas		$\Delta V \sqrt{1 - e^{-T/RC}}$	$\Delta V \sqrt{e^{-T/RC}}$
Settling Time to Within Stated % of New RMS Level	1%	4.6 τ /2.0 τ	4.6 τ /4.6 τ
	0.1%	6.9 τ /3.1 τ	6.9 τ /6.9 τ
	0.01%	9.2 τ /4.2 τ	9.2 τ /9.2 τ

Note: (τ) Settling Times for Linear RC Filter

Decibel Output (dB)

The dB output of the MX536A/MX636 originates in the squarer/divider section and works well over a 60dB range. The connection for dB measurements is shown in Figure 10. The dB output has a temperature drift of 0.03dB/°C, and in some applications may need to be compensated. Figure 10 shows a compensation scheme. The amplifier can be used to scale the output for a particular application. The values used in Figure 10 give an output of +100mV/dB.

True RMS-to-DC Converters

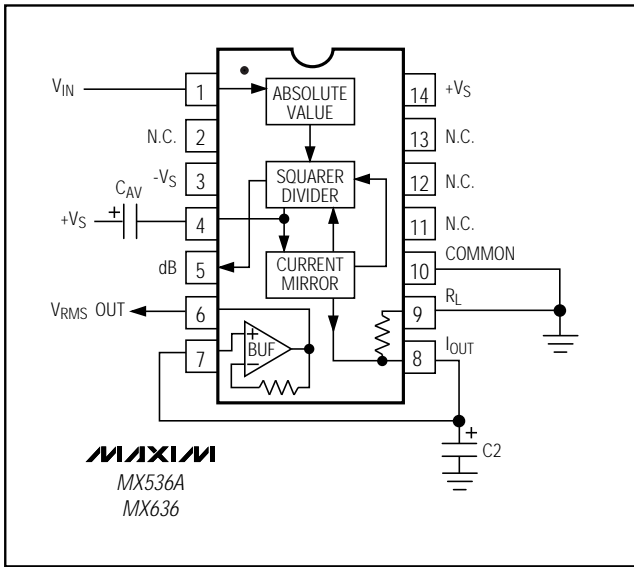

Figure 7. MX536A/MX636 with a One-Pole Output Filter

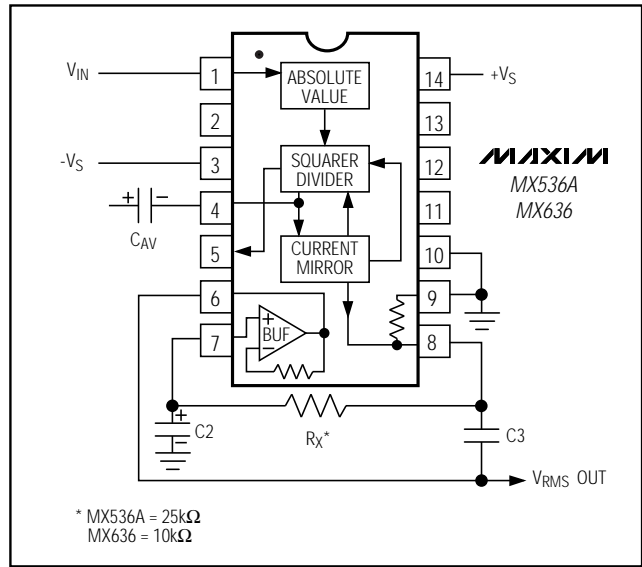

Figure 8. MX536A/MX636 with a Two-Pole Output Filter

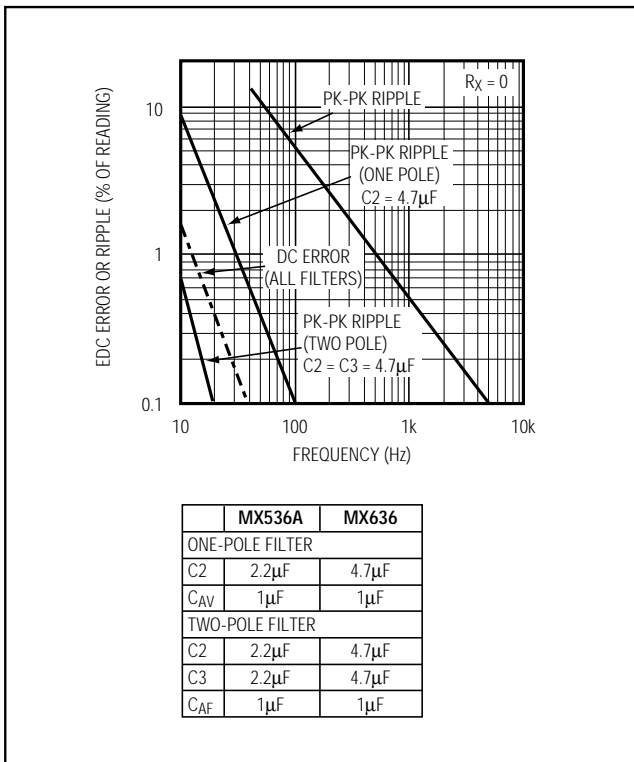

Figure 9. Performance Features of Various Filter Types for MX536A/MX636

Frequency Response

The MX536A/MX636 utilizes a logarithmic circuit in performing the RMS computation of the input signal. The bandwidth of the RMS converters is proportional to signal level. Figures 11 and 12 represent the frequency response of the converters from 10mV to 7VRMS for the MX536A and 1mV to 1V for the MX636, respectively. The dashed lines indicate the upper frequency limits for 1%, 10%, and ±3dB of reading additional error. Caution must be used when designing RMS measuring systems so that overload does not occur. The input clipping level for the MX636 is ±12V, and for the MX536A it is ±20V. A 7VRMS signal with a crest factor of 3 has a peak input of 21V.

Application in a Low-Cost DVM

A low-cost digital voltmeter (DVM) using just two integrated circuits plus supporting circuitry and LCD display is shown in Figure 13. The MAX130 is a 3 1/2 digit integrating A/D converter with precision bandgap reference. The 10MΩ input attenuator is AC coupled to pin 6 of the MX636 buffer amplifier. The output from the MX636 is connected to the MAX130 to give a direct reading to the LCD display.

True RMS-to-DC Converters

MX536A/MX636

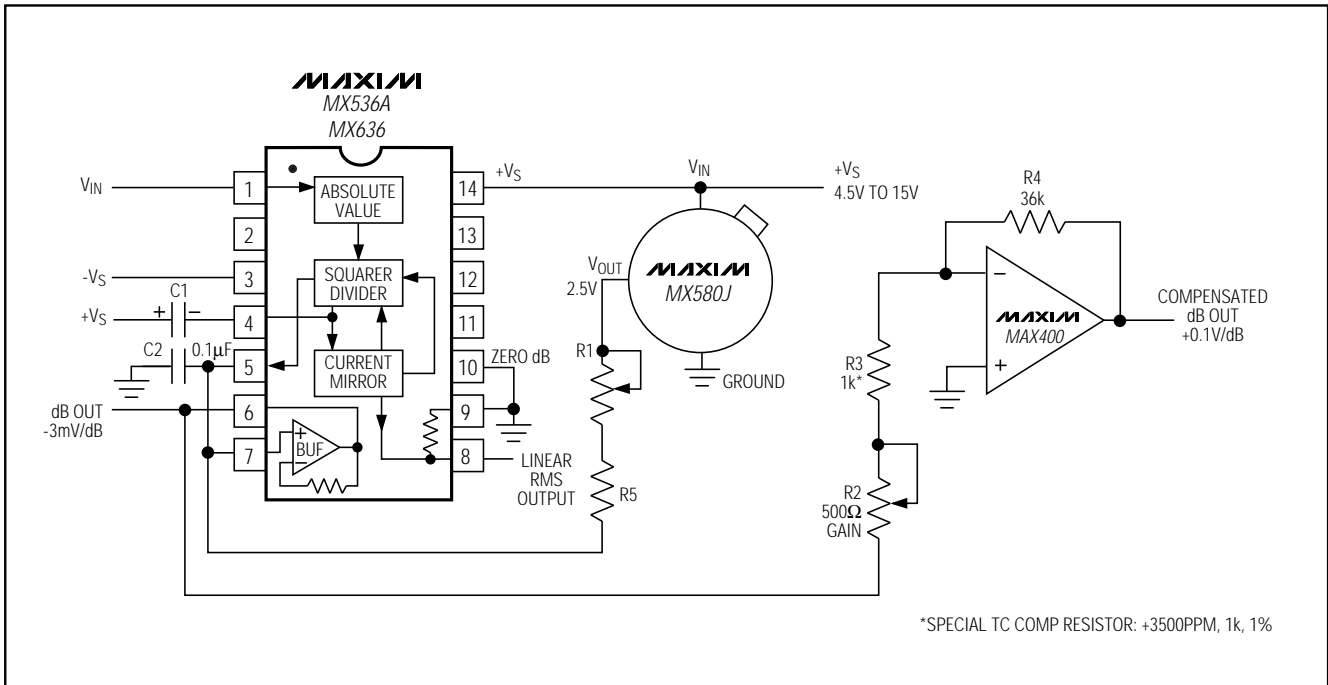

Figure 10. dB Connection

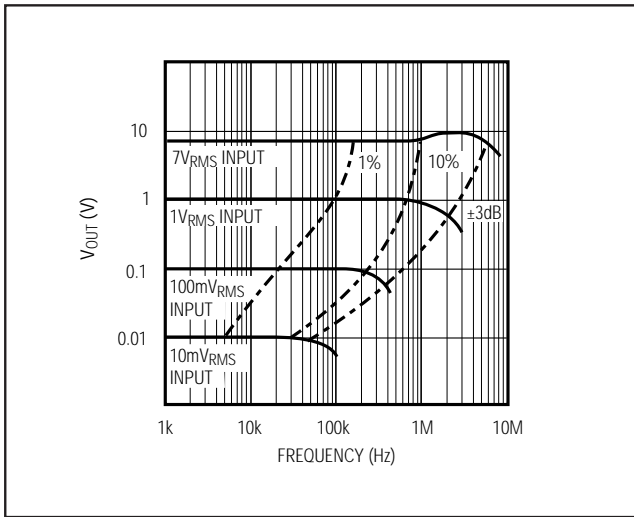

Figure 11. MX536A High-Frequency Response

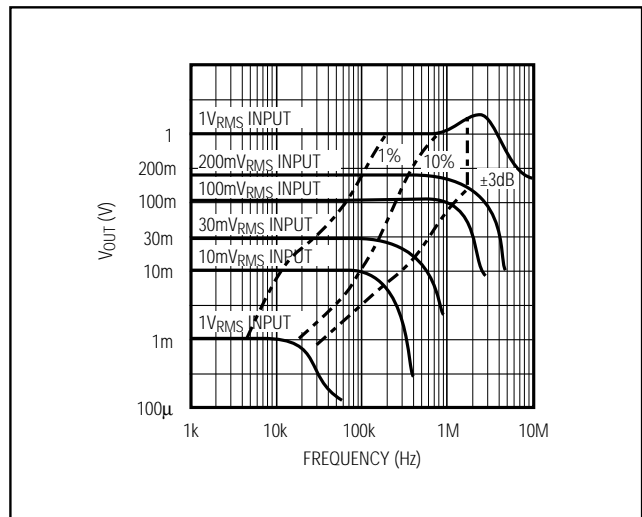

Figure 12. MX636 High-Frequency Response

True RMS-to-DC Converters

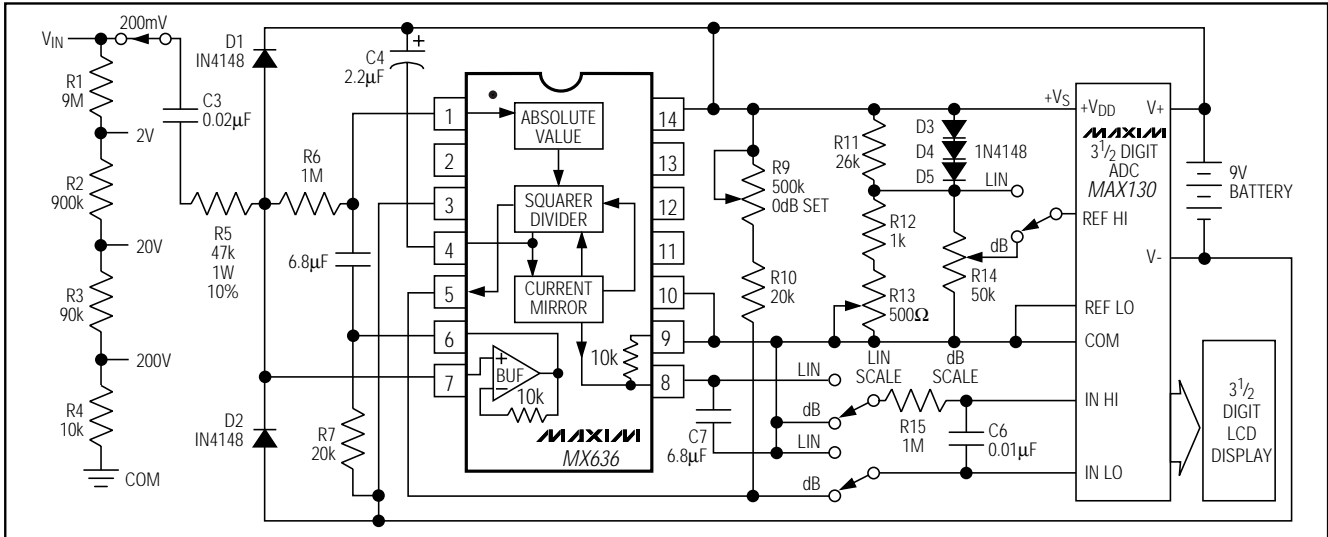
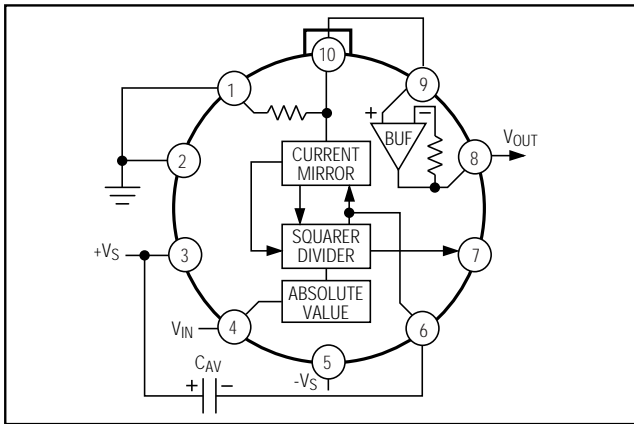
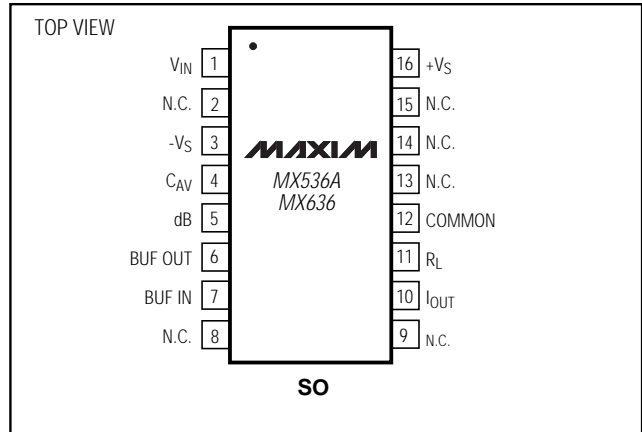

Figure 13. Portable High-Z Input RMS DPM and dB Meter

Typical Operating Circuits (continued)



Pin Configurations (continued)



Ordering Information (continued)

PART	TEMP. RANGE	PIN-PACKAGE
MX536ASH	-55°C to +125°C	10 TO-100
MX536ASQ*	-55°C to +125°C	14 CERDIP
MX636 JC/D	0°C to +70°C	Dice**
MX636JCWE	0°C to +70°C	16 Wide SO
MX636JD	0°C to +70°C	14 Ceramic
MX636JH	0°C to +70°C	10 TO-100
MX636JN	0°C to +70°C	14 Plastic DIP

PART	TEMP. RANGE	PIN-PACKAGE
MX636JQ*	0°C to +70°C	14 CERDIP
MX636KCWE	0°C to +70°C	16 Wide SO
MX636KD	0°C to +70°C	14 Ceramic
MX636KH	0°C to +70°C	10 TO-100
MX636KN	0°C to +70°C	14 Plastic DIP
MX636KQ*	0°C to +70°C	14 CERDIP

* Maxim reserves the right to ship ceramic packages in lieu of CERDIP packages.

** Dice are specified at $T_A = +25^\circ\text{C}$.

Maxim cannot assume responsibility for use of any circuitry other than circuitry entirely embodied in a Maxim product. No circuit patent licenses are implied. Maxim reserves the right to change the circuitry and specifications without notice at any time.