

### APPLICATIONS

- High Power Drives
- High Voltage Power Supplies
- DC Motor Control

### KEY PARAMETERS

|             |               |
|-------------|---------------|
| $V_{DRM}$   | 4800V         |
| $I_{T(AV)}$ | 1088A         |
| $I_{TSM}$   | 15000A        |
| $dV/dt^*$   | 300V/ $\mu$ s |
| $di/dt$     | 200A/ $\mu$ s |

\*Higher dV/dt selections available

### FEATURES

- Double Side Cooling
- High Surge Capability
- High Mean Current
- Fatigue Free

### VOLTAGE RATINGS

| Type Number | Repetitive Peak Voltages<br>$V_{DRM}$ $V_{RRM}$<br>V | Conditions  |
|-------------|--|---|
| DCR1279SD48 | 4800   | $T_{vj} = 0^\circ$ to $125^\circ$ C,<br>$I_{DRM} = I_{RRM} = 150$ mA,<br>$V_{DRM}$ , $V_{RRM}$ $t_p = 10$ ms,<br>$V_{DSM}$ & $V_{RSM} =$<br>$V_{DRM}$ & $V_{RRM} + 100$ V<br>respectively |
| DCR1279SD47 | 4700   |   |
| DCR1279SD46 | 4600   |   |
| DCR1279SD45 | 4500   |   |
| DCR1279SD44 | 4400   |   |

Lower voltage grades available.

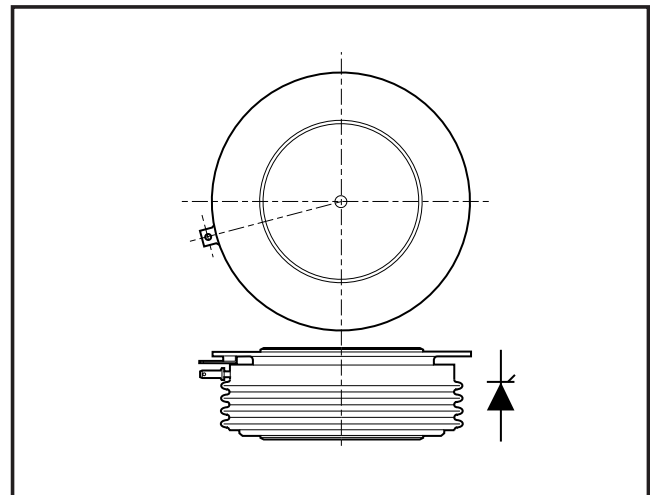

Outline type code: D.  
See package outline for further information.

### CURRENT RATINGS

$T_{case} = 60^\circ$  C unless stated otherwise.

| Symbol                                 | Parameter                            | Conditions                | Max. | Units |
|--|--------------------------------------|---------------------------|------|-------|
| <b>Double Side Cooled</b>              |                                      |                           |      |       |
| $I_{T(AV)}$                            | Mean on-state current                | Half wave resistive load, | 1088 | A     |
| $I_{T(RMS)}$                           | RMS value                            | -                         | 1709 | A     |
| $I_T$                                  | Continuous (direct) on-state current | -                         | 1574 | A     |
| <b>Single Side Cooled (Anode side)</b> |                                      |                           |      |       |
| $I_{T(AV)}$                            | Mean on-state current                | Half wave resistive load  | 762  | A     |
| $I_{T(RMS)}$                           | RMS value                            | -                         | 1197 | A     |
| $I_T$                                  | Continuous (direct) on-state current | -                         | 1034 | A     |

# DCR1279SD

## CURRENT RATINGS

$T_{case} = 80^{\circ}\text{C}$  unless stated otherwise.

| Symbol                                 | Parameter                            | Conditions                | Max. | Units |
|--|--------------------------------------|---------------------------|------|-------|
| <b>Double Side Cooled</b>              |                                      |                           |      |       |
| $I_{T(AV)}$                            | Mean on-state current                | Half wave resistive load, | 860  | A     |
| $I_{T(RMS)}$                           | RMS value                            | -                         | 1350 | A     |
| $I_T$                                  | Continuous (direct) on-state current | -                         | 1055 | A     |
| <b>Single Side Cooled (Anode side)</b> |                                      |                           |      |       |
| $I_{T(AV)}$                            | Mean on-state current                | Half wave resistive load  | 590  | A     |
| $I_{T(RMS)}$                           | RMS value                            | -                         | 930  | A     |
| $I_T$                                  | Continuous (direct) on-state current | -                         | 860  | A     |

## SURGE RATINGS

| Symbol    | Parameter                               | Conditions                                       | Max.               | Units                |
|-----------|---|--|--------------------|----------------------|
| $I_{TSM}$ | Surge (non-repetitive) on-state current | 10ms half sine; $T_{case} = 125^{\circ}\text{C}$ | 12.0               | kA                   |
| $I^2t$    | $I^2t$ for fusing                       | $V_R = 50\% V_{RRM}$ - 1/4 sine                  | $0.72 \times 10^6$ | $\text{A}^2\text{s}$ |
| $I_{TSM}$ | Surge (non-repetitive) on-state current | 10ms half sine; $T_{case} = 125^{\circ}\text{C}$ | 15.0               | kA                   |
| $I^2t$    | $I^2t$ for fusing                       | $V_R = 0$  | $1.12 \times 10^6$ | $\text{A}^2\text{s}$ |

## THERMAL AND MECHANICAL DATA

| Symbol        | Parameter                             | Conditions                                   | Min.        | Max. | Units              |                      |
|---------------|---------------------------------------|--|-------------|------|--------------------|----------------------|
| $R_{th(j-c)}$ | Thermal resistance - junction to case | Double side cooled                           | dc          | -    | 0.020              | $^{\circ}\text{C/W}$ |
|               |                                       | Single side cooled                           | Anode dc    | -    | 0.036              | $^{\circ}\text{C/W}$ |
|               |                                       |  | Cathode dc  | -    | 0.044              | $^{\circ}\text{C/W}$ |
| $R_{th(c-h)}$ | Thermal resistance - case to heatsink | Clamping force 22.0kN with mounting compound | Double side | -    | 0.004              | $^{\circ}\text{C/W}$ |
|               |                                       |  | Single side | -    | 0.008              | $^{\circ}\text{C/W}$ |
| $T_{vj}$      | Virtual junction temperature          | On-state (conducting)                        |             | -    | 135                | $^{\circ}\text{C}$   |
|               |                                       | Reverse (blocking)                           |             | -    | 125                | $^{\circ}\text{C}$   |
| $T_{stg}$     | Storage temperature range             |  | -55         | 125  | $^{\circ}\text{C}$ |                      |
| -             | Clamping force                        |  | 22.0        | 24.0 | kN                 |                      |

## DYNAMIC CHARACTERISTICS

| Symbol            | Parameter  | Conditions   | Typ.            | Max.  | Units      |            |
|-------------------|--|--|-----------------|-------|------------|------------|
| $I_{RRM}/I_{DRM}$ | Peak reverse and off-state current               | At $V_{RRM}/V_{DRM}$ , $T_{case} = 125^{\circ}C$   | -               | 150   | mA         |            |
| dV/dt             | Maximum linear rate of rise of off-state voltage | To 67% $V_{DRM}$ , $T_j = 125^{\circ}C$ . Gate open circuit.   | -               | 300   | V/ $\mu s$ |            |
| di/dt             | Rate of rise of on-state current                 | From 67% $V_{DRM}$ to 1000A<br>Gate source 10V, 5 $\Omega$<br>$t_r \leq 0.5\mu s$ , $T_j = 125^{\circ}C$ | Repetitive 50Hz | -     | 100        | A/ $\mu s$ |
|                   |  |  | Non-repetitive  | -     | 200        | A/ $\mu s$ |
| $V_{T(TO)}$       | Threshold voltage                                | At $T_{vj} = 125^{\circ}C$   | -               | 1.14  | V          |            |
| $r_T$             | On-state slope resistance                        | At $T_{vj} = 125^{\circ}C$   | -               | 0.587 | m $\Omega$ |            |
| $t_{gd}$          | Delay time                                       | $V_D = 67\% V_{DRM}$ , Gate source 30V, 15 $\Omega$<br>$t_r = 0.5\mu s$ , $T_j = 25^{\circ}C$            | -               | 2.5   | $\mu s$    |            |
| $I_L$             | Latching current                                 | $T_j = 25^{\circ}C$ , $V_D = 5V$   | 300             | 1000  | mA         |            |
| $I_H$             | Holding current                                  | $T_j = 25^{\circ}C$ , $R_{g-k} = \infty$   | -               | 500   | mA         |            |

## GATE TRIGGER CHARACTERISTICS AND RATINGS

| Symbol      | Parameter                 | Conditions                                | Max. | Units |
|-------------|---------------------------|---|------|-------|
| $V_{GT}$    | Gate trigger voltage      | $V_{DRM} = 5V$ , $T_{case} = 25^{\circ}C$ | 4.0  | V     |
| $I_{GT}$    | Gate trigger current      | $V_{DRM} = 5V$ , $T_{case} = 25^{\circ}C$ | 400  | mA    |
| $V_{GD}$    | Gate non-trigger voltage  | At $V_{DRM}$ , $T_{case} = 125^{\circ}C$  | 0.25 | V     |
| $V_{FGM}$   | Peak forward gate voltage | Anode positive with respect to cathode    | 30   | V     |
| $V_{FGN}$   | Peak forward gate voltage | Anode negative with respect to cathode    | 0.25 | V     |
| $V_{RGM}$   | Peak reverse gate voltage |   | 5    | V     |
| $I_{FGM}$   | Peak forward gate current | Anode positive with respect to cathode    | 10   | A     |
| $P_{GM}$    | Peak gate power           | See table, fig.4                          | 150  | W     |
| $P_{G(AV)}$ | Mean gate power           |   | 5    | W     |

CURVES

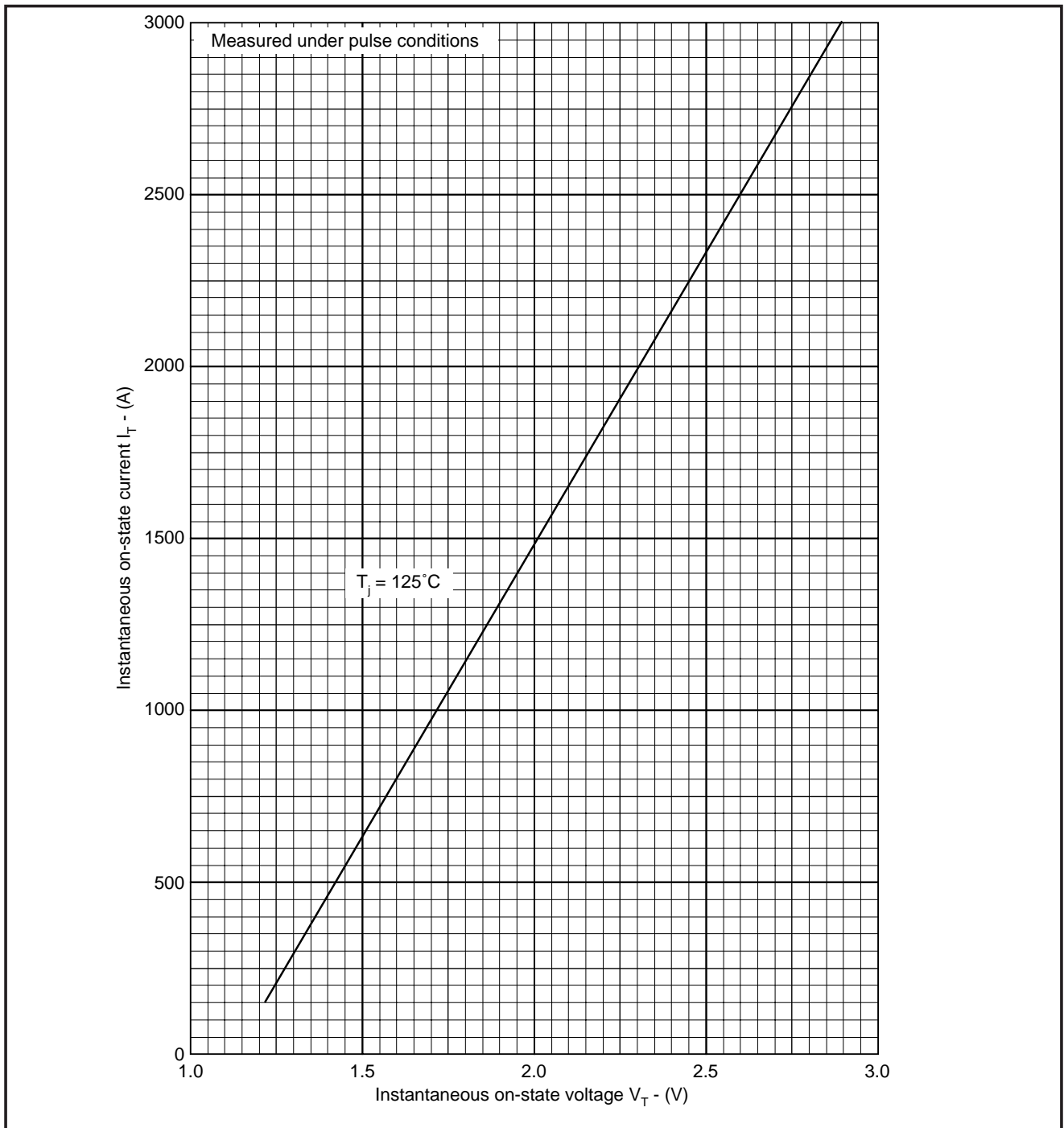

Fig.1 Maximum (limit) on-state characteristics

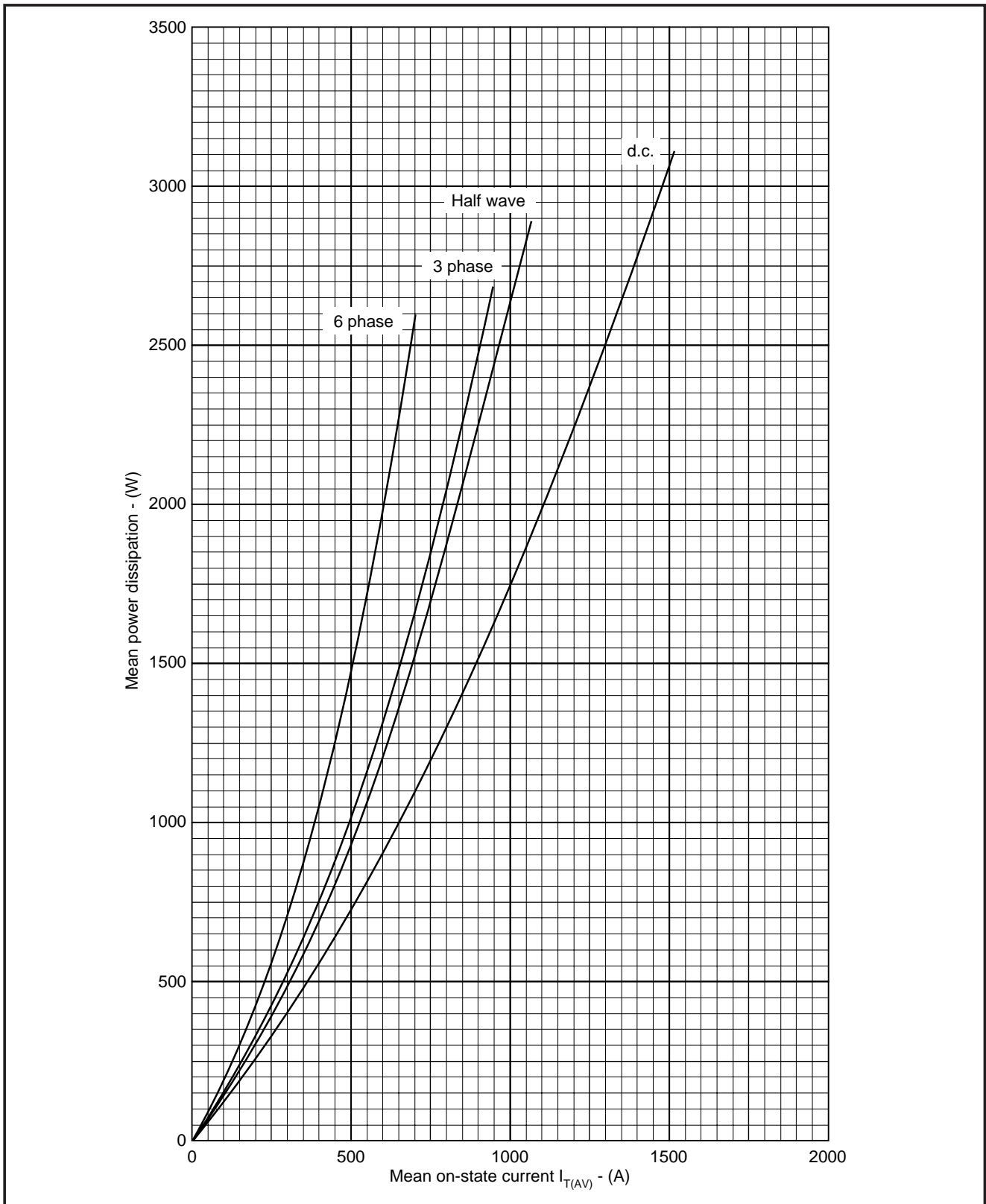

Fig.2 Dissipation curves

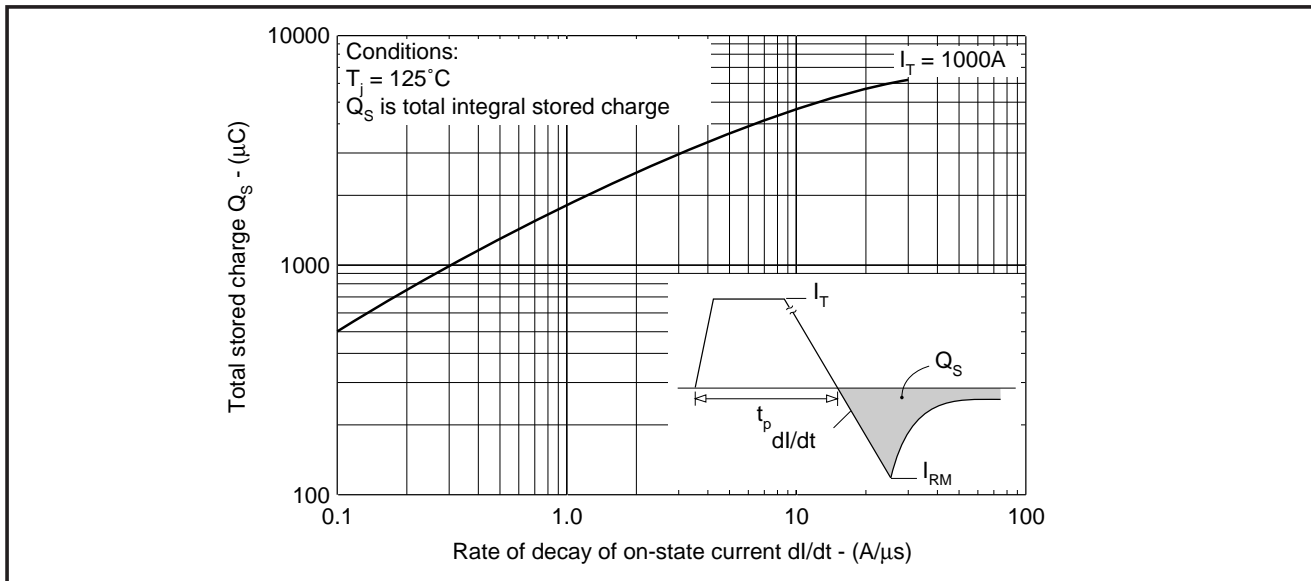

Fig.3 Stored charge

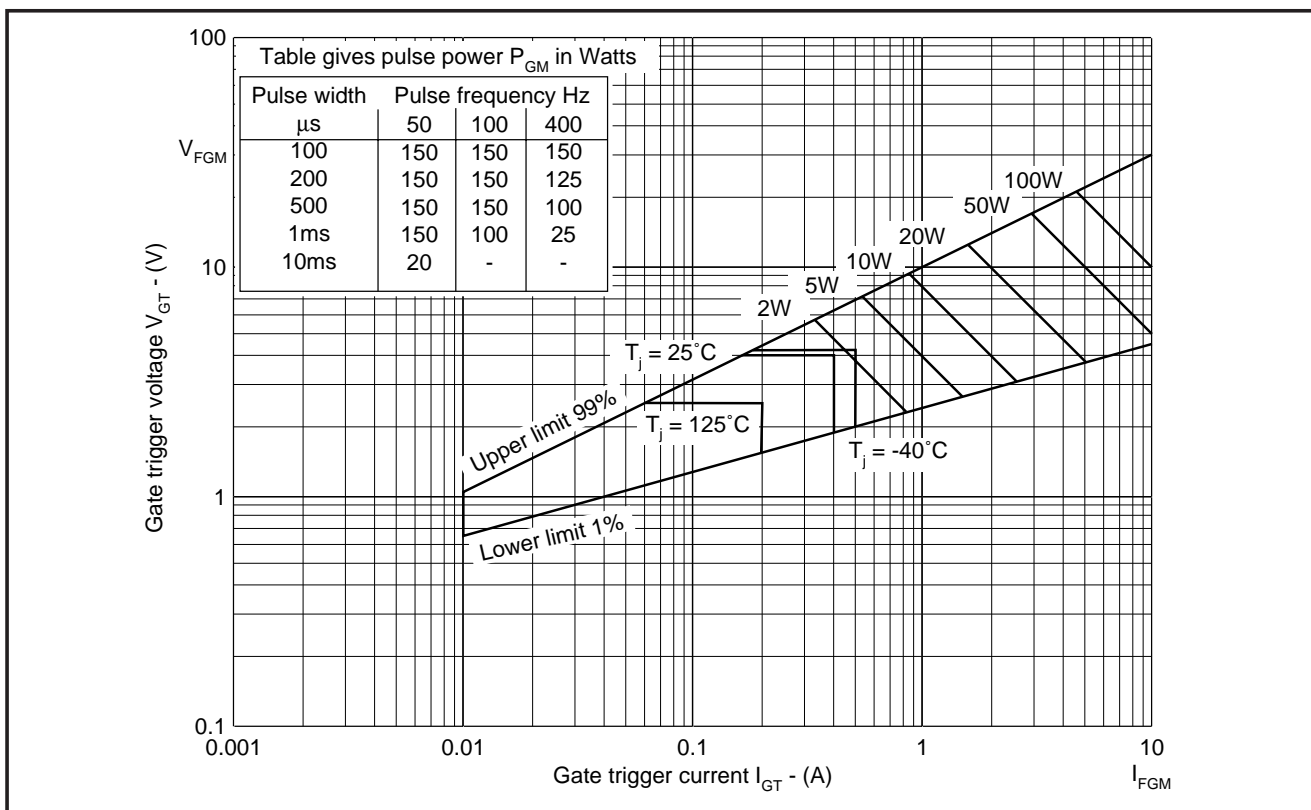

Fig.4 Gate characteristics

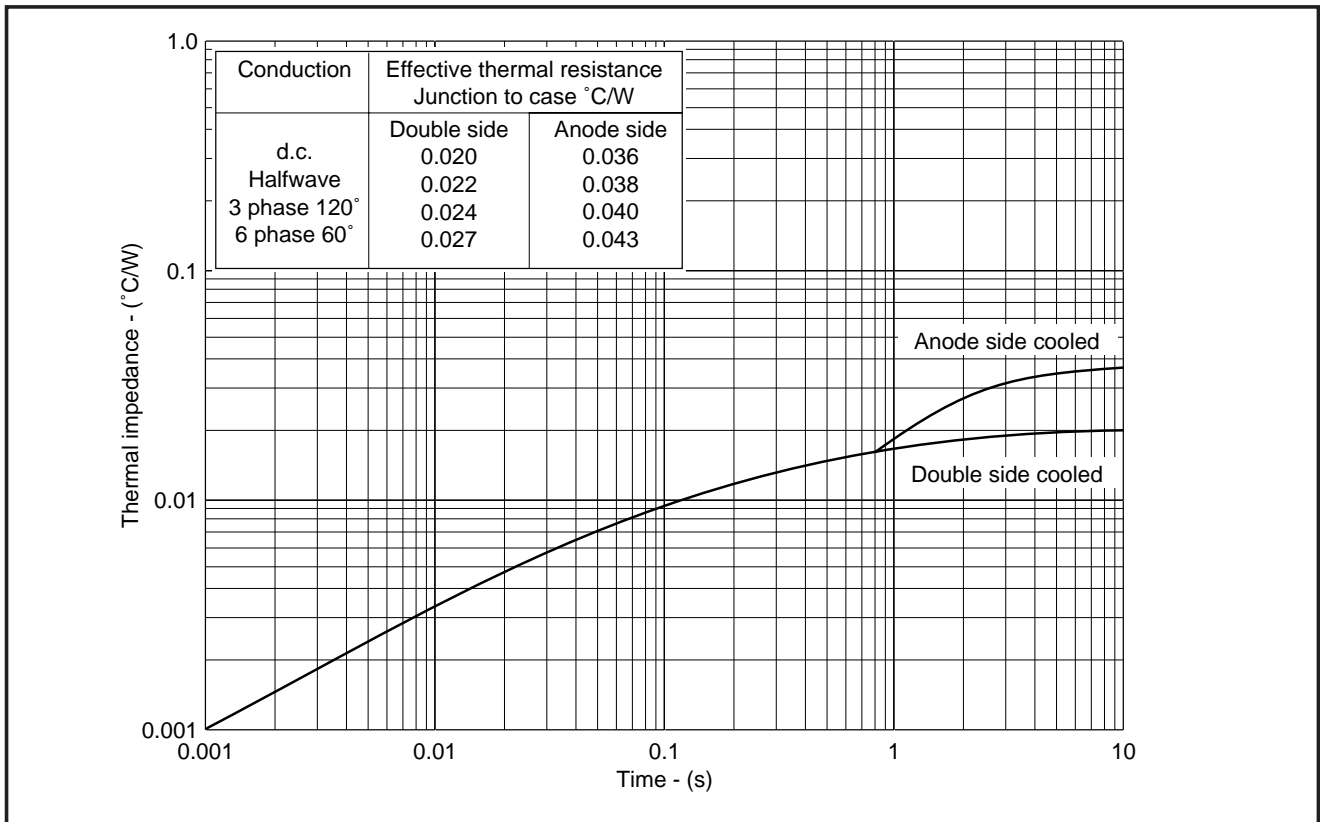

Fig.5 Maximum (limit) transient thermal impedance - junction to case

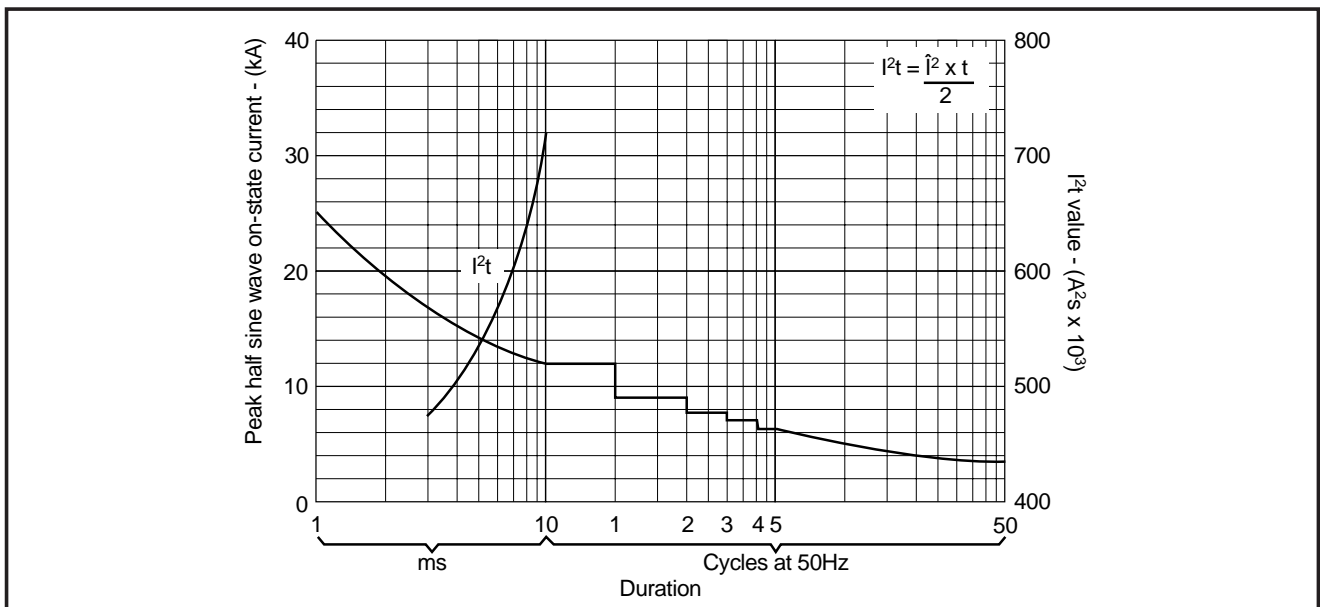
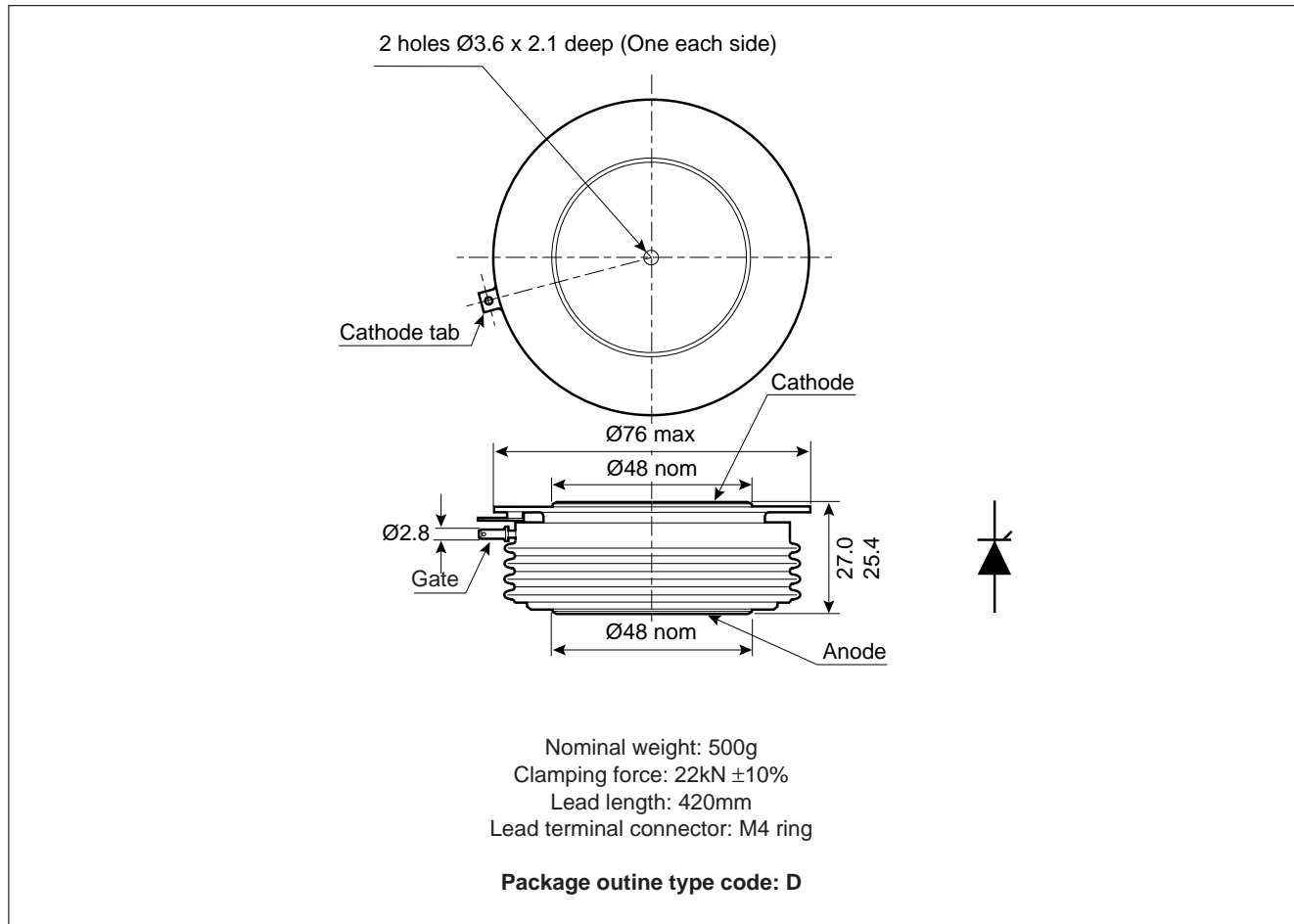

Fig.6 Surge (non-repetitive) on-state current vs time (with 50% V<sub>RRM</sub> at T<sub>case</sub> 125°C)

# DCR1279SD

## PACKAGE DETAILS

For further package information, please contact your local Customer Service Centre. All dimensions in mm, unless stated otherwise. DO NOT SCALE.



## ASSOCIATED PUBLICATIONS

| Title  | Application Note |
|--|------------------|
|  | Number           |
| Calculating the junction temperature or power semiconductors | AN4506           |
| Gate triggering and the use of gate characteristics          | AN4840           |
| Recommendations for clamping power semiconductors            | AN4839           |
| The effect of temperature on thyristor performance           | AN4870           |
| Thyristor and diode measurement with a multi-meter           | AN4853           |
| Turn-on performance of thyristors in parallel                | AN4999           |
| Use of $V_{TO}$ , $r_T$ on-state characteristic              | AN5001           |



## POWER ASSEMBLY CAPABILITY

The Power Assembly group was set up to provide a support service for those customers requiring more than the basic semiconductor, and has developed a flexible range of heatsink / clamping systems in line with advances in device types and the voltage and current capability of our semiconductors.

We offer an extensive range of air and liquid cooled assemblies covering the full range of circuit designs in general use today. The Assembly group continues to offer high quality engineering support dedicated to designing new units to satisfy the growing needs of our customers.

Using the up to date CAD methods our team of design and applications engineers aim to provide the Power Assembly Complete solution (PACs).

## DEVICE CLAMPS

Disc devices require the correct clamping force to ensure their safe operation. The PACs range offers a varied selection of pre-loaded clamps to suit all of our manufactured devices. This include cube clamps for single side cooling of 'T' 22mm

Clamps are available for single or double side cooling, with high insulation versions for high voltage assemblies.

Please refer to our application note on device clamping, AN4839

## HEATSINKS

Power Assembly has it's own proprietary range of extruded aluminium heatsinks. They have been designed to optimise the performance of our semiconductors. Data with respect to air natural, forced air and liquid cooling (with flow rates) is available on request.

For further information on device clamps, heatsinks and assemblies, please contact your nearest Sales Representative or the factory.



<http://www.dynexsemi.com>

e-mail: [power\\_solutions@dynexsemi.com](mailto:power_solutions@dynexsemi.com)

HEADQUARTERS OPERATIONS  
**DYNEX SEMICONDUCTOR LTD**  
 Doddington Road, Lincoln.  
 Lincolnshire. LN6 3LF. United Kingdom.  
 Tel: 00-44-(0)1522-500500  
 Fax: 00-44-(0)1522-500550

**DYNEX POWER INC.**  
 Unit 7 - 58 Antares Drive,  
 Nepean, Ontario, Canada K2E 7W6.  
 Tel: 613.723.7035  
 Fax: 613.723.1518  
 Toll Free: 1.888.33.DYNEX (39639)

CUSTOMER SERVICE CENTRES  
**France, Benelux, Italy and Spain** Tel: +33 (0)1 69 18 90 00. Fax: +33 (0)1 64 46 54 50  
**North America** Tel: 011-800-5554-5554. Fax: 011-800-5444-5444  
**UK, Germany, Scandinavia & Rest Of World** Tel: +44 (0)1522 500500. Fax: +44 (0)1522 500020

SALES OFFICES  
**France, Benelux, Italy and Spain** Tel: +33 (0)1 69 18 90 00. Fax: +33 (0)1 64 46 54 50  
**Germany** Tel: 07351 827723  
**North America** Tel: (613) 723-7035. Fax: (613) 723-1518. Toll Free: 1.888.33.DYNEX (39639) /  
 Tel: (831) 440-1988. Fax: (831) 440-1989 / Tel: (949) 733-3005. Fax: (949) 733-2986.  
**UK, Germany, Scandinavia & Rest Of World** Tel: +44 (0)1522 500500. Fax: +44 (0)1522 500020  
 These offices are supported by Representatives and Distributors in many countries world-wide.  
 © Dynex Semiconductor 2000 Publication No. DS4643-4 Issue No. 4.0 January 2000  
 TECHNICAL DOCUMENTATION – NOT FOR RESALE. PRINTED IN UNITED KINGDOM

### Datasheet Annotations:

Dynex Semiconductor annotate datasheets in the top right hand corner of the front page, to indicate product status. The annotations are as follows:-

**Target Information:** This is the most tentative form of information and represents a very preliminary specification. No actual design work on the product has been started.

**Preliminary Information:** The product is in design and development. The datasheet represents the product as it is understood but details may change.

**Advance Information:** The product design is complete and final characterisation for volume production is well in hand.

**No Annotation:** The product parameters are fixed and the product is available to datasheet specification.

This publication is issued to provide information only which (unless agreed by the Company in writing) may not be used, applied or reproduced for any purpose nor form part of any order or contract nor to be regarded as a representation relating to the products or services concerned. No warranty or guarantee express or implied is made regarding the capability, performance or suitability of any product or service. The Company reserves the right to alter without prior notice the specification, design or price of any product or service. Information concerning possible methods of use is provided as a guide only and does not constitute any guarantee that such methods of use will be satisfactory in a specific piece of equipment. It is the user's responsibility to fully determine the performance and suitability of any equipment using such information and to ensure that any publication or data used is up to date and has not been superseded. These products are not suitable for use in any medical products whose failure to perform may result in significant injury or death to the user. All products and materials are sold and services provided subject to the Company's conditions of sale, which are available on request.

All brand names and product names used in this publication are trademarks, registered trademarks or trade names of their respective owners.