

Features

- 400MHz Bandwidth ($R_L=50\Omega$)
- High voltage Gain 45dB ($R_L=1k\Omega$)
- 70dB Gain Control Range
- High Output Level at Low Gain
- Surface Mount Plastic Package
- Low Cost

Applications

- RF/IF Amplifier
- High Gain Mixers
- Video Amplifiers

Description

The SL6140 is an integrated broadband AGC amplifier, designed on an advanced bipolar process. The amplifier provides over 15dB of linear gain into 50Ω at 400MHz. Gain control is also provided with over 70dB of dynamic range. The SL6140 offers over 45dB of voltage gain with an R_L of $1k\Omega$.

Ordering Information

SL6140/NA/MP Industrial temperature range
miniature plastic package
SL6140/NA/MPTC Tape and Reel

The SL6140 (Figure 3) is a high gain amplifier with an AGC control capable of reducing the gain of the amplifier by over 70dB. The gain is adjustable by applying a voltage to the AGC input via an external resistor (R_{AGC}), the value of which adjusts the curve of gain reduction versus control voltage (see Figure 4). As the output stage of the amplifier is an open collector the maximum voltage gain is determined by R_L . With load resistance of $1k\Omega$ the single ended voltage gain is 45dB and with a load resistance of 50Ω the voltage gain is 15dB ($20\log_{10} V_{OUT}/V_{IN}$). Another parameter that depends on the load resistance is the bandwidth: 25MHz for $R_L = 1k\Omega$, as compared with 400MHz for $R_L = 50\Omega$. R_L is chosen to give either the required bandwidth or voltage gain for the circuit.

Figure 7 through to 10 show the typical S parameters for the device. Figures 11 and 12 show the typical variation in 3rd order intercept performance with AGC.

In any application, the substrate should be connected to the most negative point in the circuit, usually to the same point as pin 3.

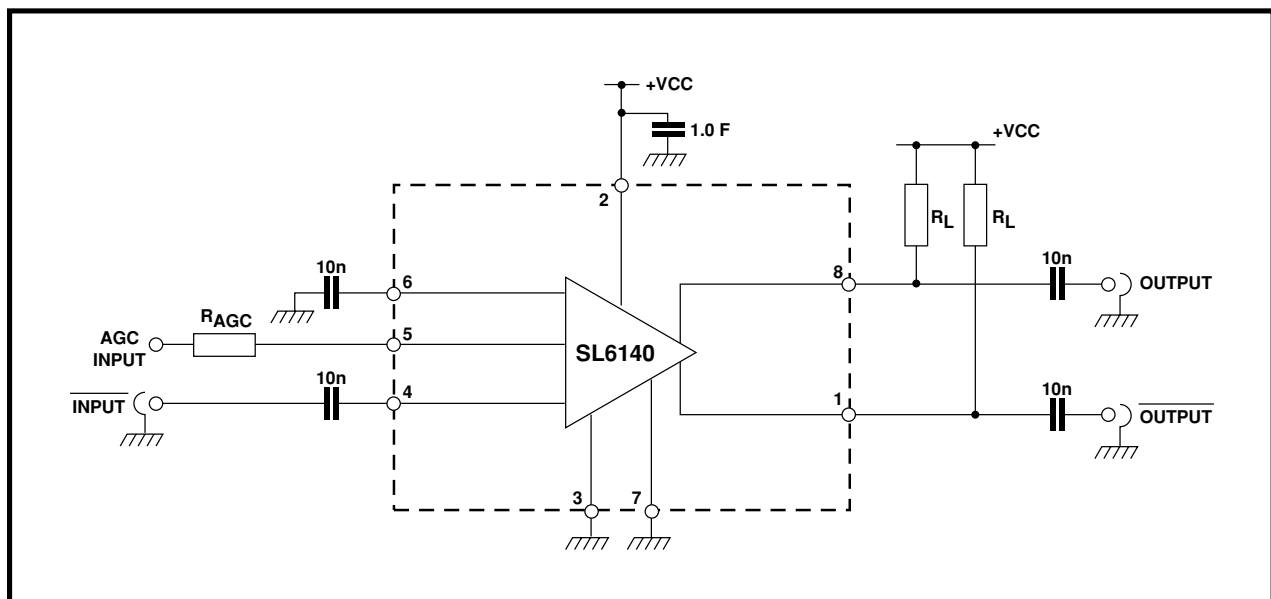

Figure 1 Typical Application

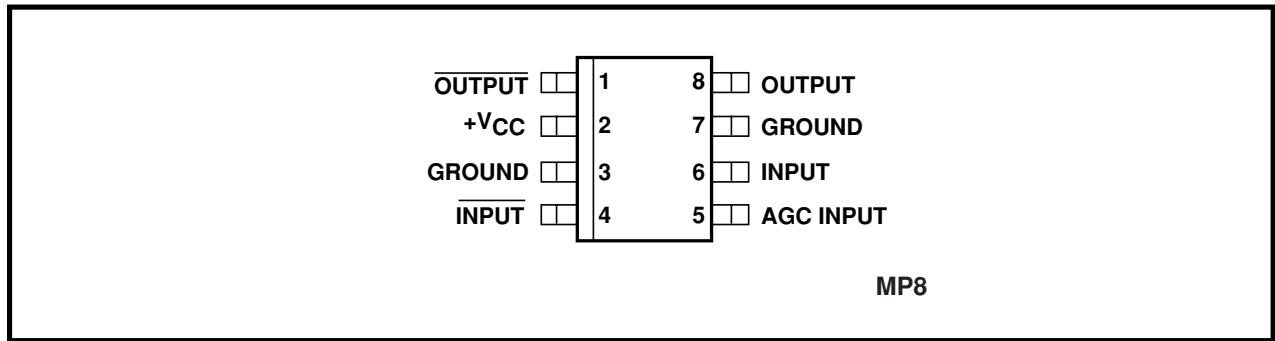

Figure 2 Pin Connections Diagram (top view)

Electrical Characteristics

$T_{amb} = 25^{\circ}\text{C}$, $V_{CC} = 12\text{V} +5\%$, $V_{IN} = 1\text{mV}_{\text{RMS}}$, Frequency = 6MHz, Load (R_L) = 10KOHms, $R_{AGC} = 22\text{KOHm}$
 These characteristics are guaranteed over the following conditions (unless otherwise stated)

Characteristic	Pin	Value			Units	Conditions
		Min	Typ	Max		
Supply current	5,6,7		19	23	mA	No input signal
Output stage current	5,6 (sum)	5	7	9	mA	No input signal
Output current matching (magnitude of difference of output currents)	5,6		1.0		mA	
AGC range	2	60	75		dB	See Figure 4 & Note 1 ($V_{AGC} = 0\text{V}$ to 10V)
Voltage gain (single ended)	5,6	40	45		dB	$R_L = 1\text{k}\Omega$ See Figure 5 & Note 1 Tuned input and output $R_L = 50\Omega$
	5,6		55		dB	
Bandwidth (-3dB)	5,6		25		MHz	$R_L = 1\text{k}\Omega$ See Figure 5 $R_L = 50\Omega$
			400			
Maximum output level (single ended)	5,6				V p-p	Note 1
Noise figure	5,6		5		dB	Test CCT Figure 13

Note. 1 Guaranteed but not tested.

Absolute Maximum Ratings

Supply voltage, V_{CC}	+18V
Input voltage (differential)	+5V
AGC supply	V_{CC}
Storage temperature	-55°C to +150°C
Operating temperature range	
SL6140 MP	-40°C to +85°C at 200mW
Chip operating temperature	
SL6140 MP	+150°C

Thermal Resistance

Chip-to-ambient			
SL6140	MP		163°C/W
Chip-to-case			
SL6140	MP		57°C/W

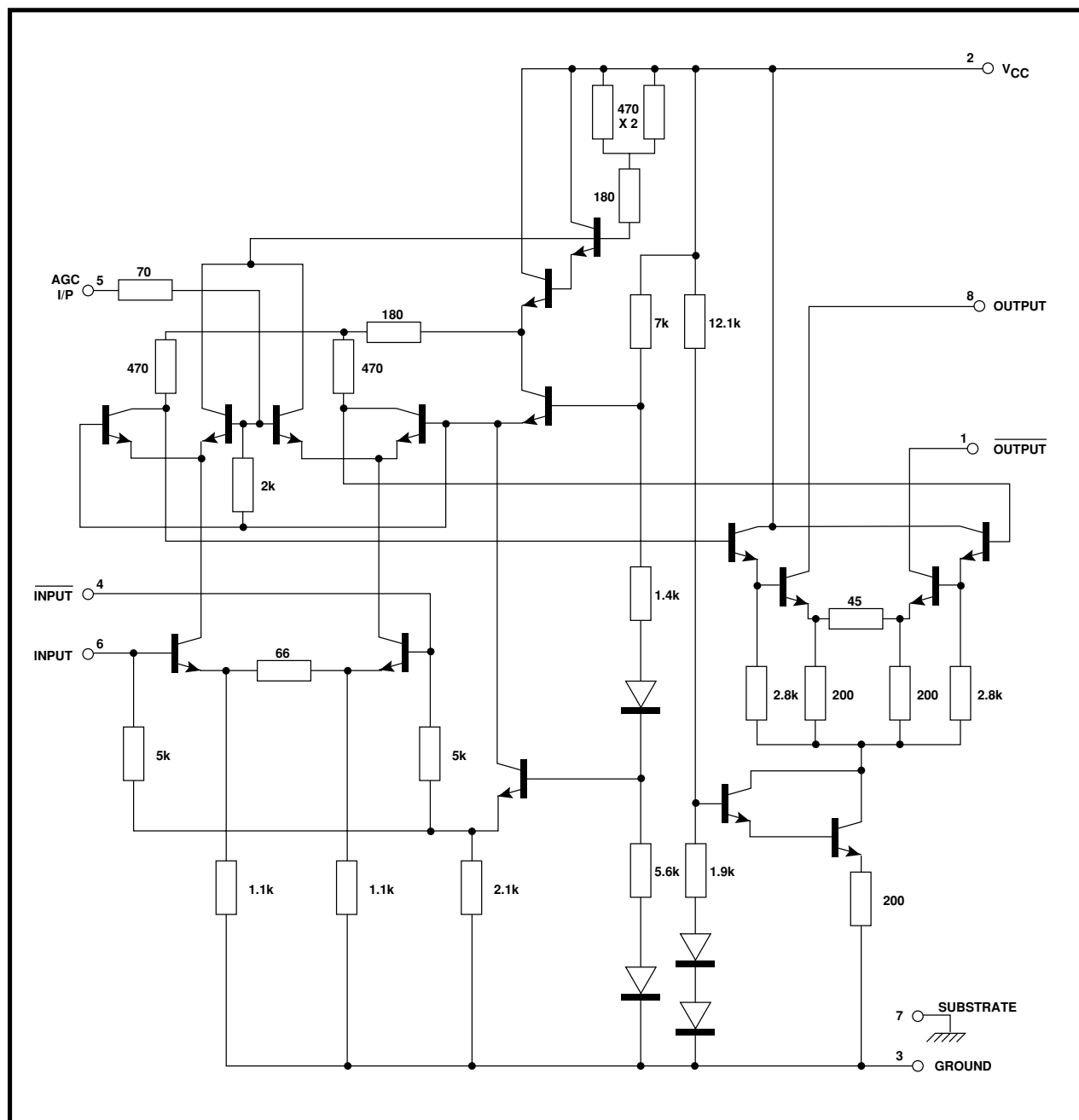

Figure 3 Full Circuit Diagram of SL6140

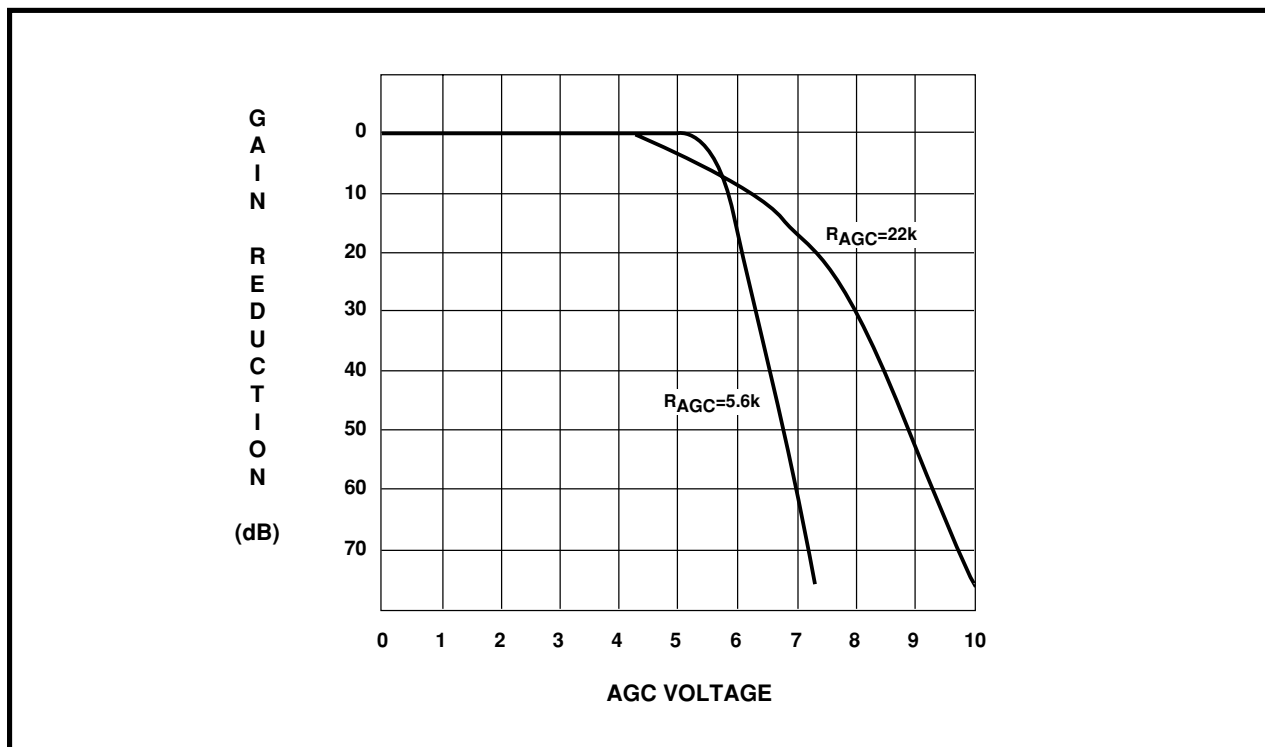

Figure 4 Gain Reduction v. AGC Voltage

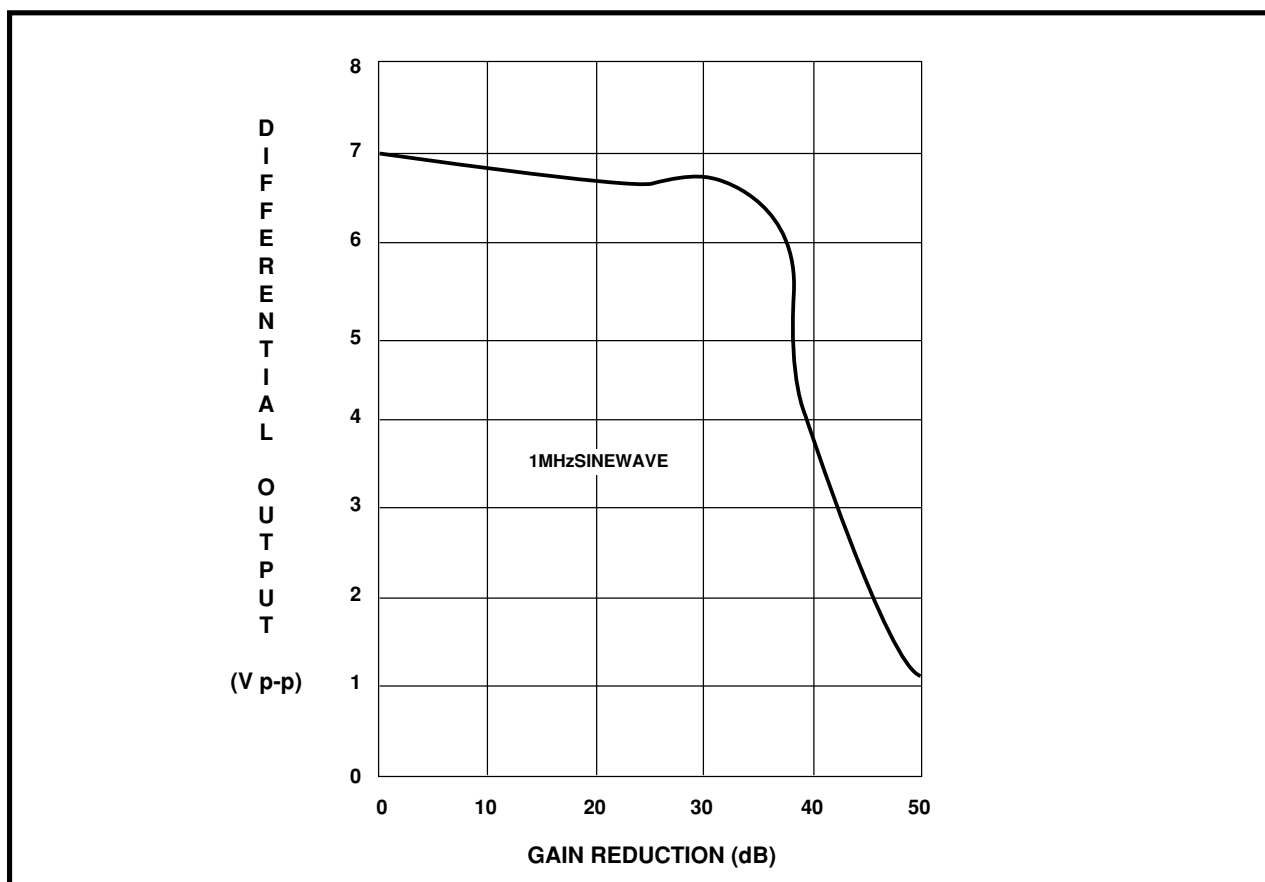

Figure 5 Max Differential O/P Voltage v. Gain Reduction

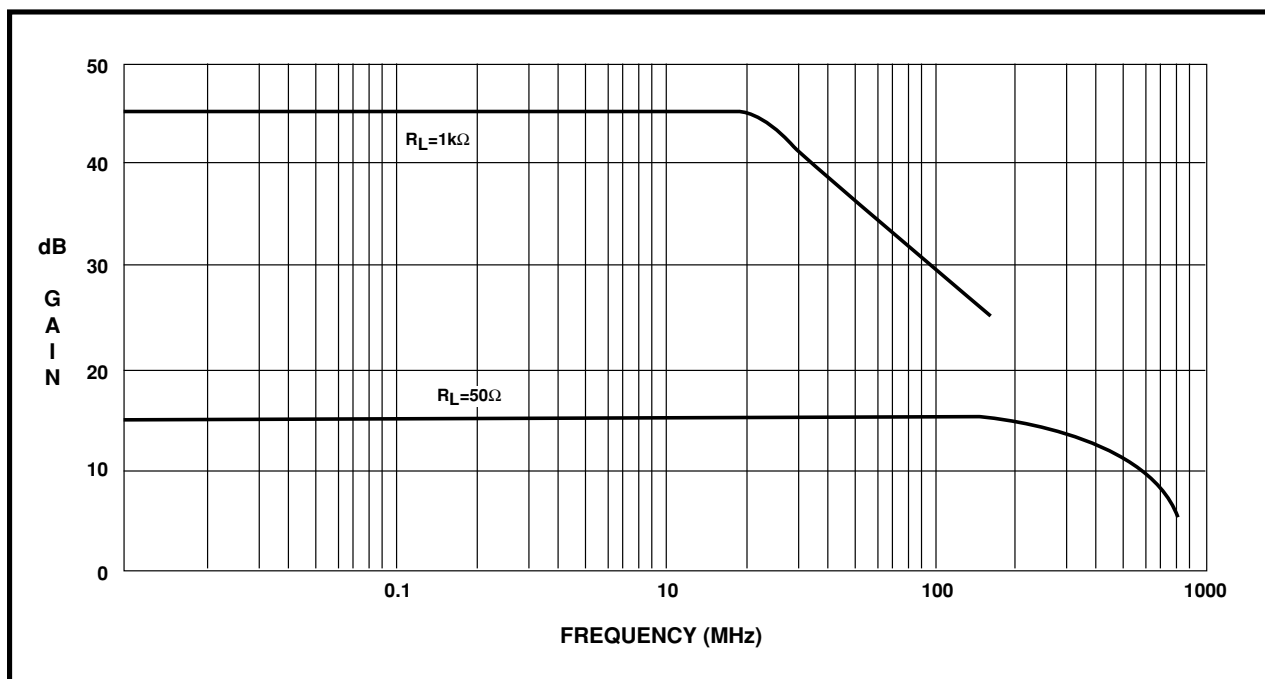

Figure 6 Voltage Gain v. Frequency

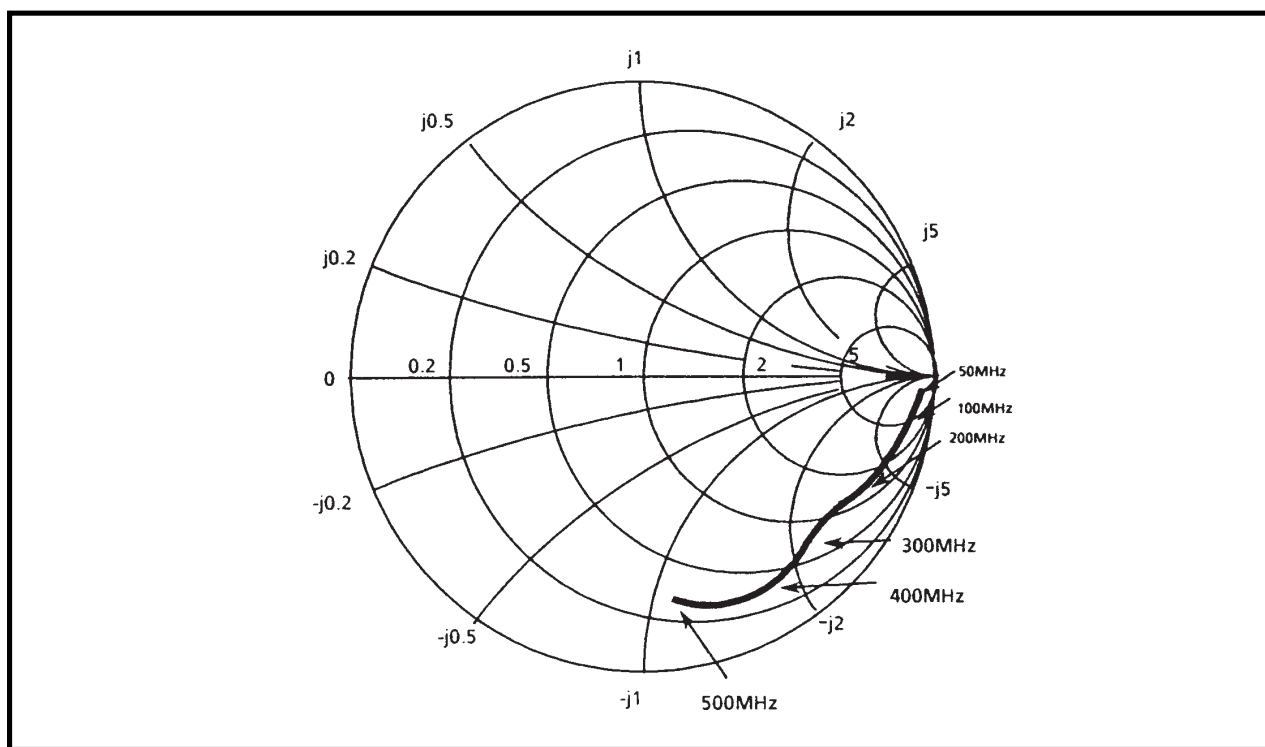

Figure 7 Input Impedance 50Ω System

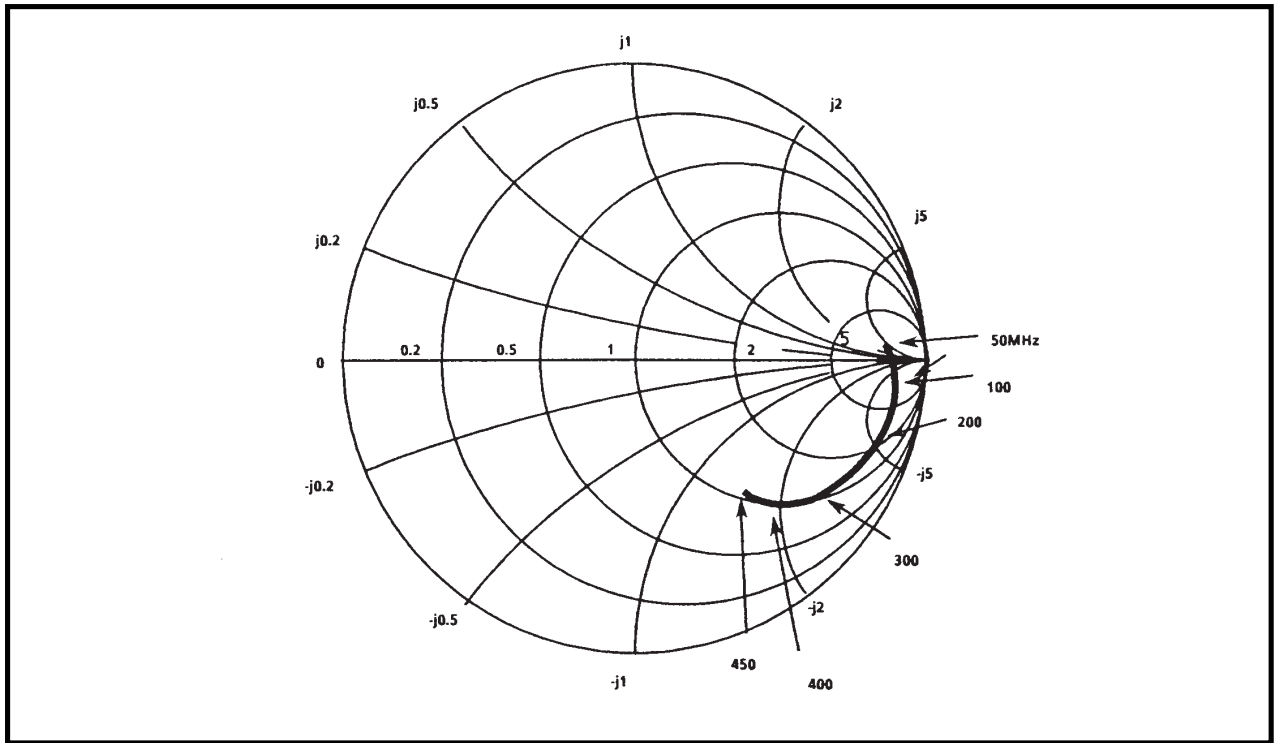

Figure 8 Output Impedance 50Ω System

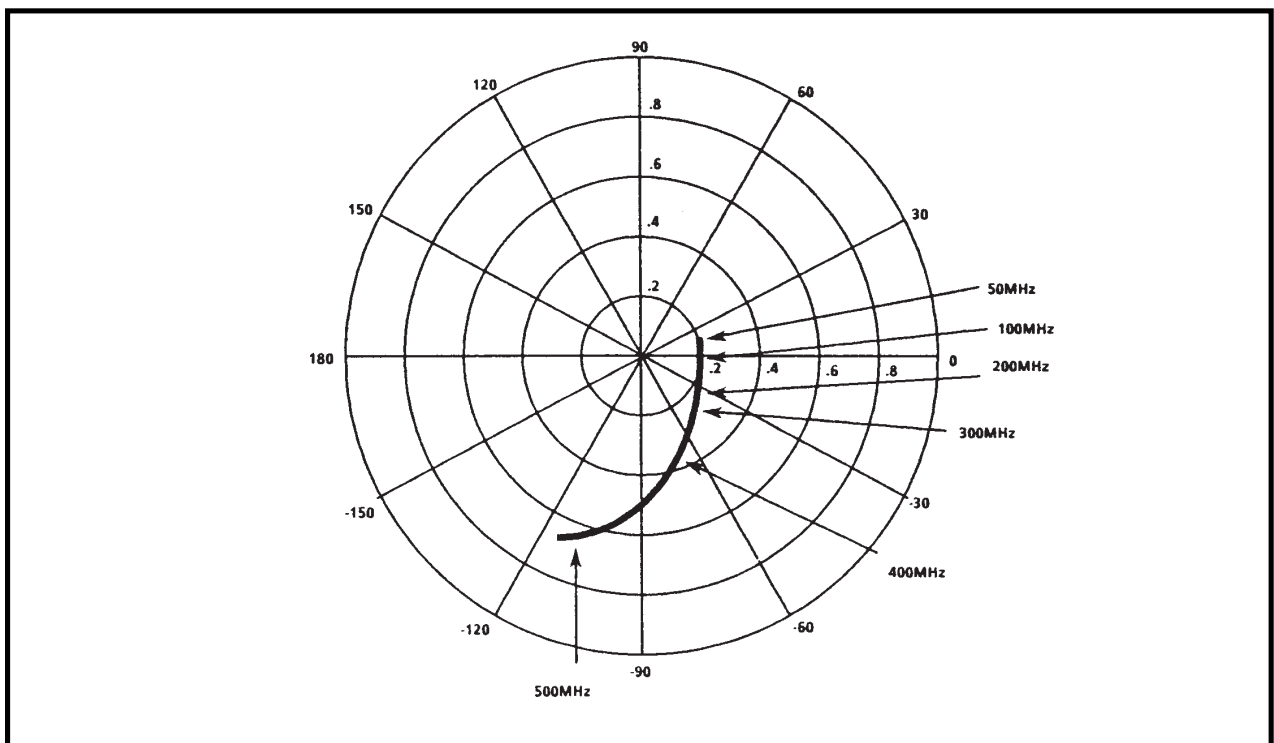

Figure 9 Reverse Transmission Coefficient S_{12} SL6140

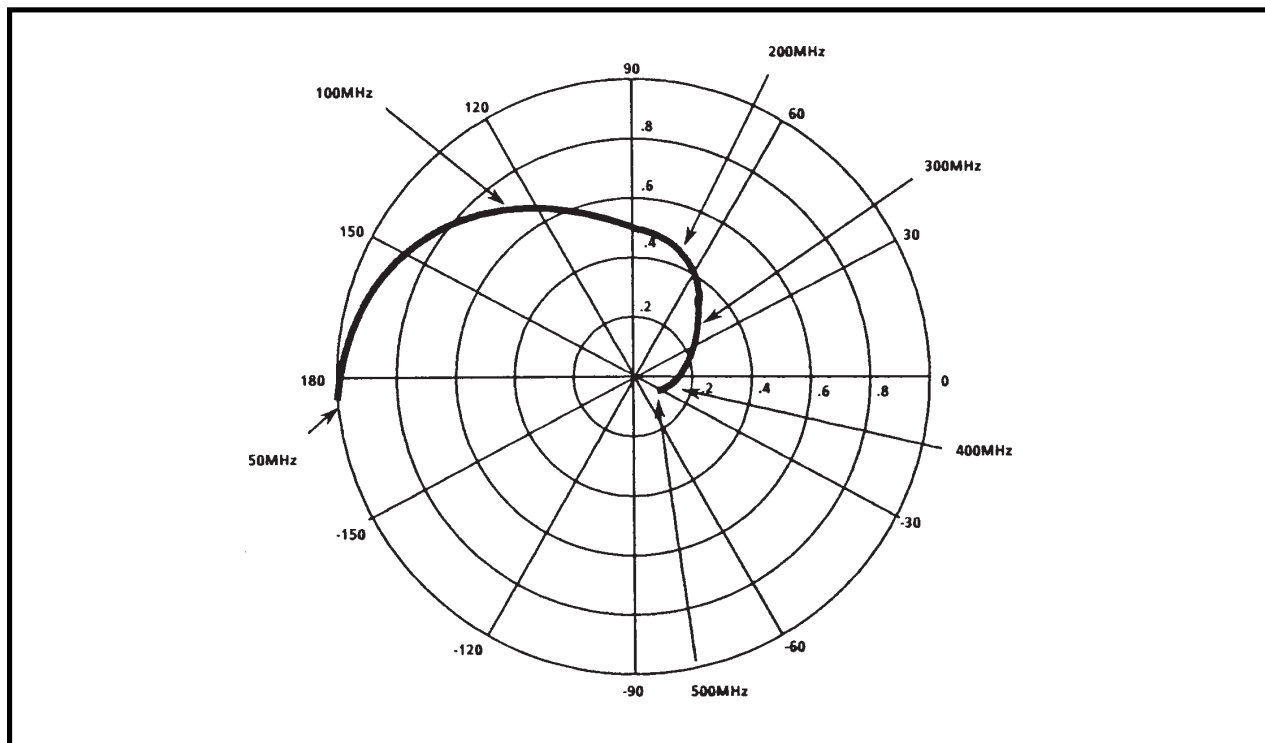

Figure 10 Forward Transmission Coefficient S_{12} SL6140

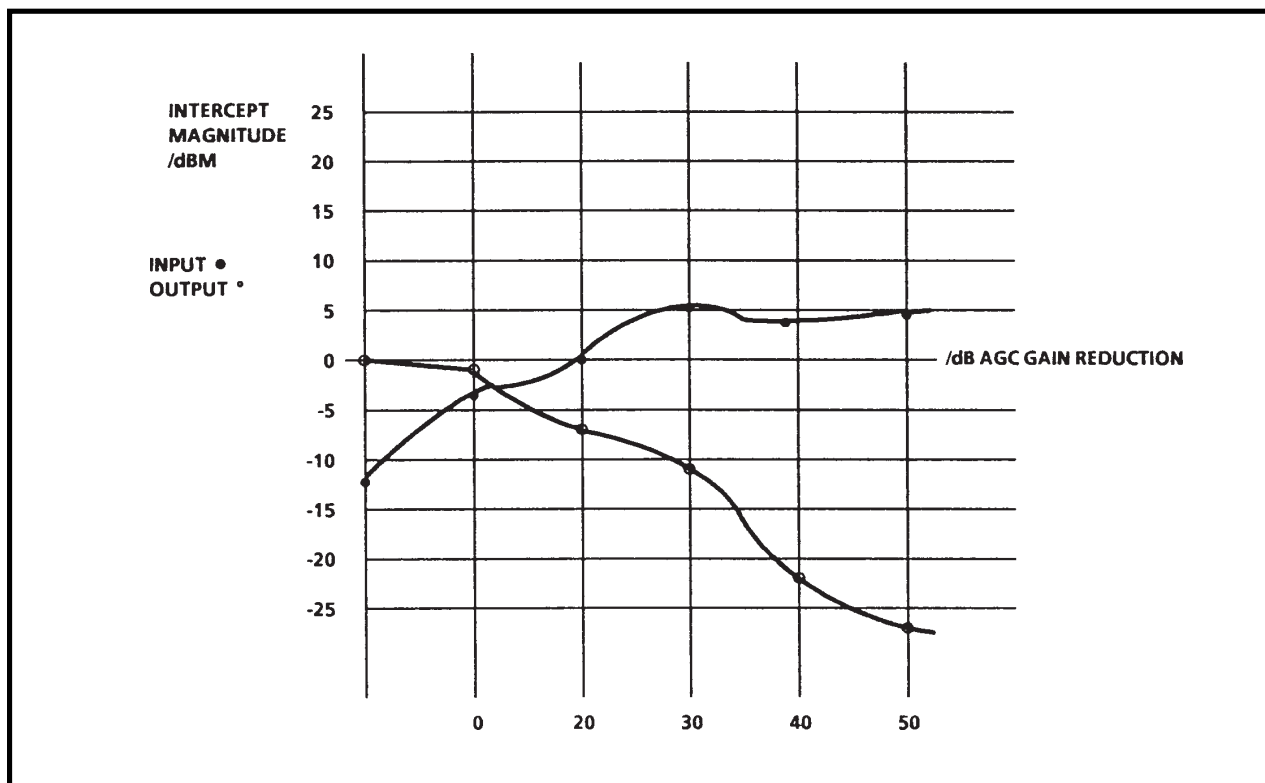

Figure 11 3rd Order Intercept Point Against Gain Reduction At 250.0MHz and 254.0MHz

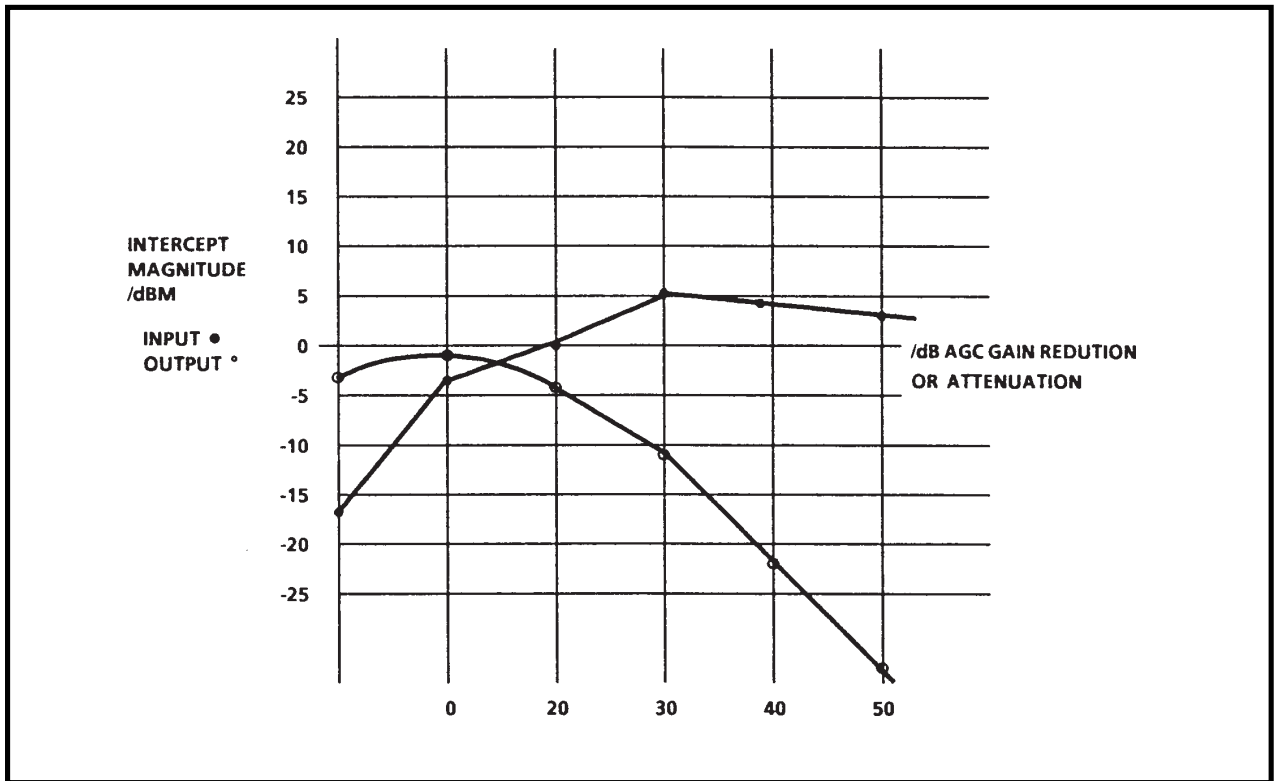

Figure 12 3rd Order Intercept Point Against Gain Reduction At 100.0MHz and 104.0MHz

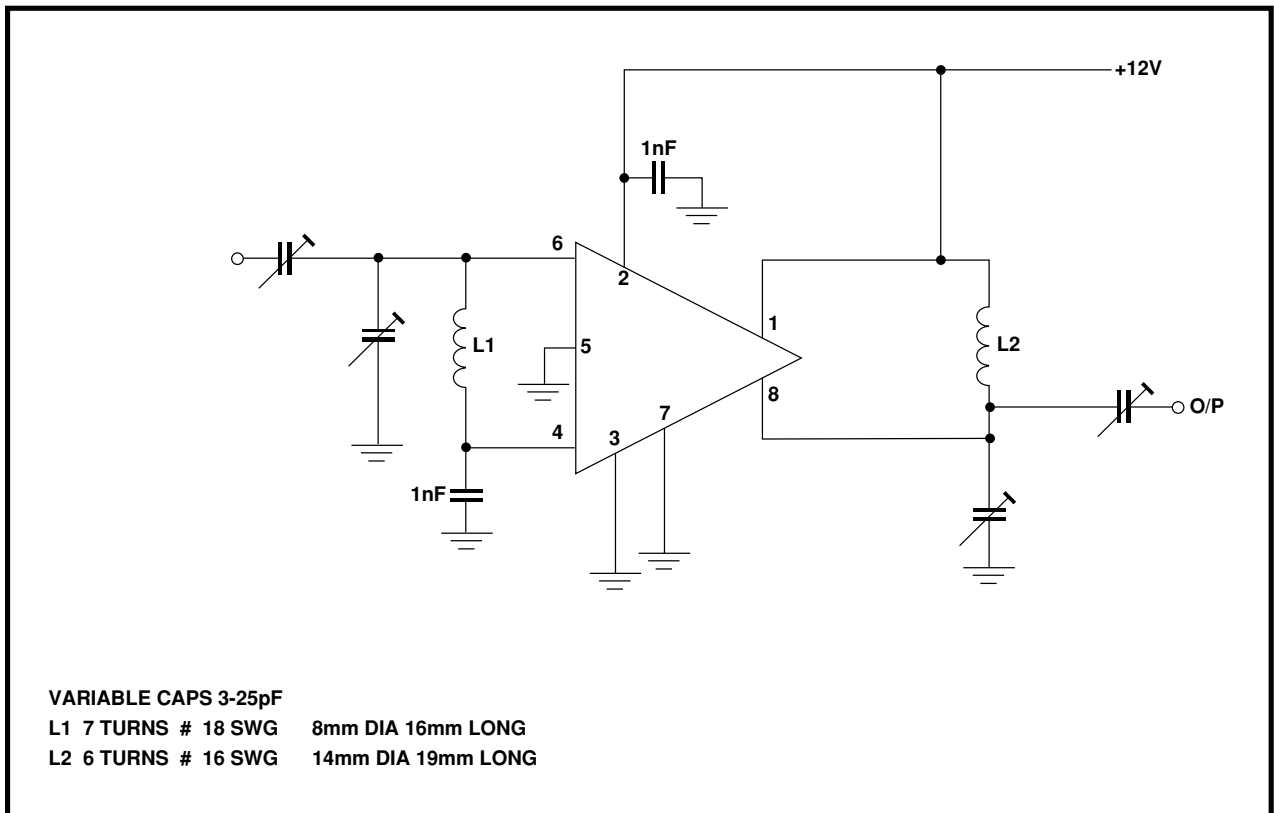
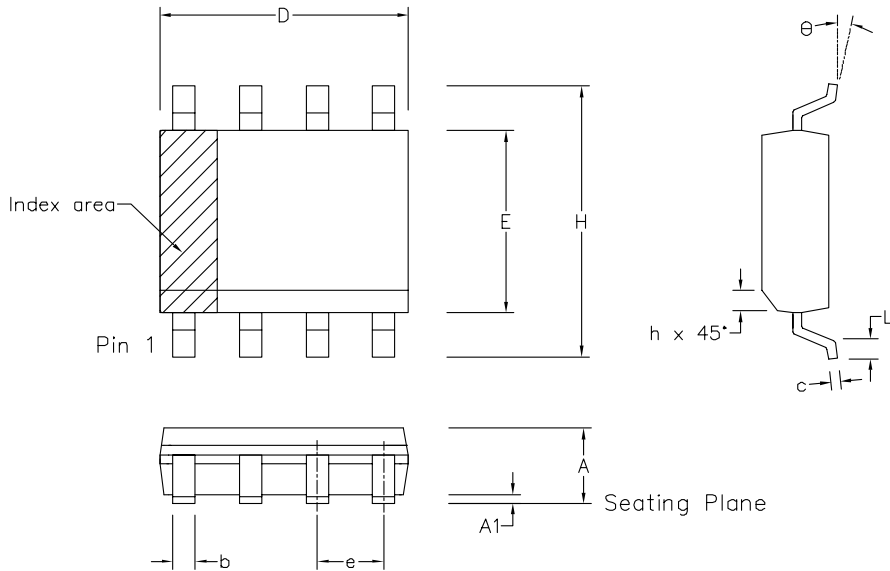

Figure 13 50MHz Noise Figure Test Circuit



	Min mm	Max mm	Min inch	Max inch
A	1.35	1.75	0.053	0.069
A1	0.10	0.25	0.004	0.010
D	4.80	5.00	0.189	0.197
H	5.80	6.20	0.228	0.244
E	3.80	4.00	0.150	0.157
L	0.40	1.27	0.016	0.050
e	1.27 BSC		0.050 BSC	
b	0.33	0.51	0.013	0.020
c	0.19	0.25	0.008	0.010
O	0°	8°	0°	8°
h	0.25	0.50	0.010	0.020
Pin Features				
N	8		8	
Conforms to JEDEC MS-012AA Iss. C				

Notes:

1. The chamfer on the body is optional. If it not present, a visual index feature, e.g. a dot, must be located within the cross-hatched area.
2. Controlling dimension are in inches.
3. Dimension D do not include mould flash, protusion or gate burrs. These shall not exceed 0.006" per side.
4. Dimension $E1$ do not include inter-lead flash or protusion. These shall not exceed 0.010" per side.
5. Dimension b does not include dambar protusion/intrusion. Allowable dambar protusion shall be 0.004" total in excess of b dimension.

© Mitel					ORIGINATING SITE: SWNDON	
ISSUE	1	2	3	4	MITEL SEMICONDUCTOR	
ACN	006745	201936	202595	203705		
DATE	5APR95	27FEB97	12JUN97	9DEC97		
APPROVED						
					Title: Package Outline Drawing for 8 lds SOIC(N)-0.150" Body Width (MP)	
					Drawing Number GPD00010	



<http://www.mitelsemi.com>

World Headquarters - Canada

Tel: +1 (613) 592 2122
Fax: +1 (613) 592 6909

North America

Tel: +1 (770) 486 0194
Fax: +1 (770) 631 8213

Asia/Pacific

Tel: +65 333 6193
Fax: +65 333 6192

**Europe, Middle East,
and Africa (EMEA)**

Tel: +44 (0) 1793 518528
Fax: +44 (0) 1793 518581

Information relating to products and services furnished herein by Mitel Corporation or its subsidiaries (collectively "Mitel") is believed to be reliable. However, Mitel assumes no liability for errors that may appear in this publication, or for liability otherwise arising from the application or use of any such information, product or service or for any infringement of patents or other intellectual property rights owned by third parties which may result from such application or use. Neither the supply of such information or purchase of product or service conveys any license, either express or implied, under patents or other intellectual property rights owned by Mitel or licensed from third parties by Mitel, whatsoever. Purchasers of products are also hereby notified that the use of product in certain ways or in combination with Mitel, or non-Mitel furnished goods or services may infringe patents or other intellectual property rights owned by Mitel.

This publication is issued to provide information only and (unless agreed by Mitel in writing) may not be used, applied or reproduced for any purpose nor form part of any order or contract nor to be regarded as a representation relating to the products or services concerned. The products, their specifications, services and other information appearing in this publication are subject to change by Mitel without notice. No warranty or guarantee express or implied is made regarding the capability, performance or suitability of any product or service. Information concerning possible methods of use is provided as a guide only and does not constitute any guarantee that such methods of use will be satisfactory in a specific piece of equipment. It is the user's responsibility to fully determine the performance and suitability of any equipment using such information and to ensure that any publication or data used is up to date and has not been superseded. Manufacturing does not necessarily include testing of all functions or parameters. These products are not suitable for use in any medical products whose failure to perform may result in significant injury or death to the user. All products and materials are sold and services provided subject to Mitel's conditions of sale which are available on request.

M Mitel (design) and ST-BUS are registered trademarks of MITEL Corporation
Mitel Semiconductor is an ISO 9001 Registered Company
Copyright 1999 MITEL Corporation
All Rights Reserved
Printed in CANADA

TECHNICAL DOCUMENTATION - NOT FOR RESALE