

TFT COLOR LCD MODULE
NL128102AC20-07**33cm (13 type), 1280 × 1024 pixels, Full color****Vertical screen expansion (Multi-scan), Incorporated backlight with inverter****DESCRIPTION**

NL128102AC20-07 is a TFT (thin film transistor) active matrix color liquid crystal display (LCD) comprising amorphous silicon TFT attached to each signal electrode, a driving circuit and a backlight. NL128102AC20-07 has a built-in backlight/inverter.

The 33 cm diagonal display area contains 1280 × 1024 pixels and can input analog signals and can display full-color (more than 16 million colors) simultaneously and can display of SXGA, XGA, SVGA, VGA, VGA-TEXT, PC-9801, NTSC, and PAL.

FEATURES

- Analog RGB interface
- Vertical screen expansion (Multi-scan) SXGA, XGA, SVGA, VGA, VGA-TEXT, PC-9801, NTSC, PAL
- High luminous / Low reflection
- Incorporated edge-light type backlight with inverter.

APPLICATIONS

- Engineering workstation (EWS), Personal computer (PC), Word processor
- Display terminals for control system
- New media
- Monitors for process controller

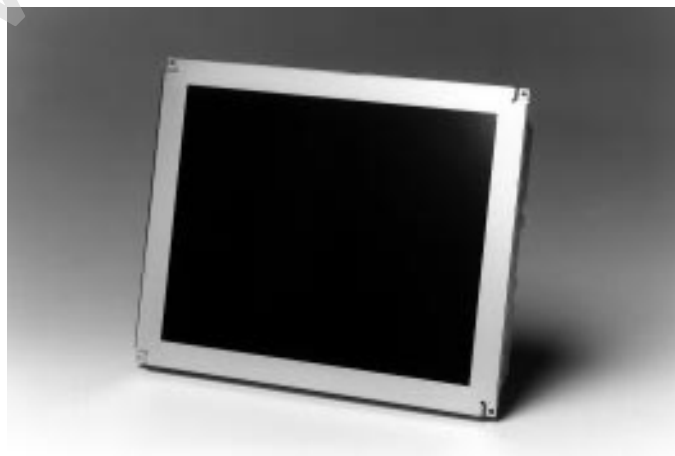

STRUCTURE AND FUNCTIONS

A TFT color LCD module comprises a TFT LCD panel, LSIs for driving liquid crystal, and a backlight. The TFT LCD panel is composed of a TFT array glass substrate superimposed on a color filter glass substrate with liquid crystal filled in the narrow gap between two substrates. The backlight apparatus is located on the backside of the LCD panel.

RGB (Red, Green, Blue) data signals are sent to LCD panel drivers after modulation into suitable forms for active matrix addressing through signal processor.

Each of the liquid crystal cells acts as an electro-optical switch that controls the light transmission from the backlight by a signal applied to a signal electrode through the TFT switch.

BLOCK DIAGRAM

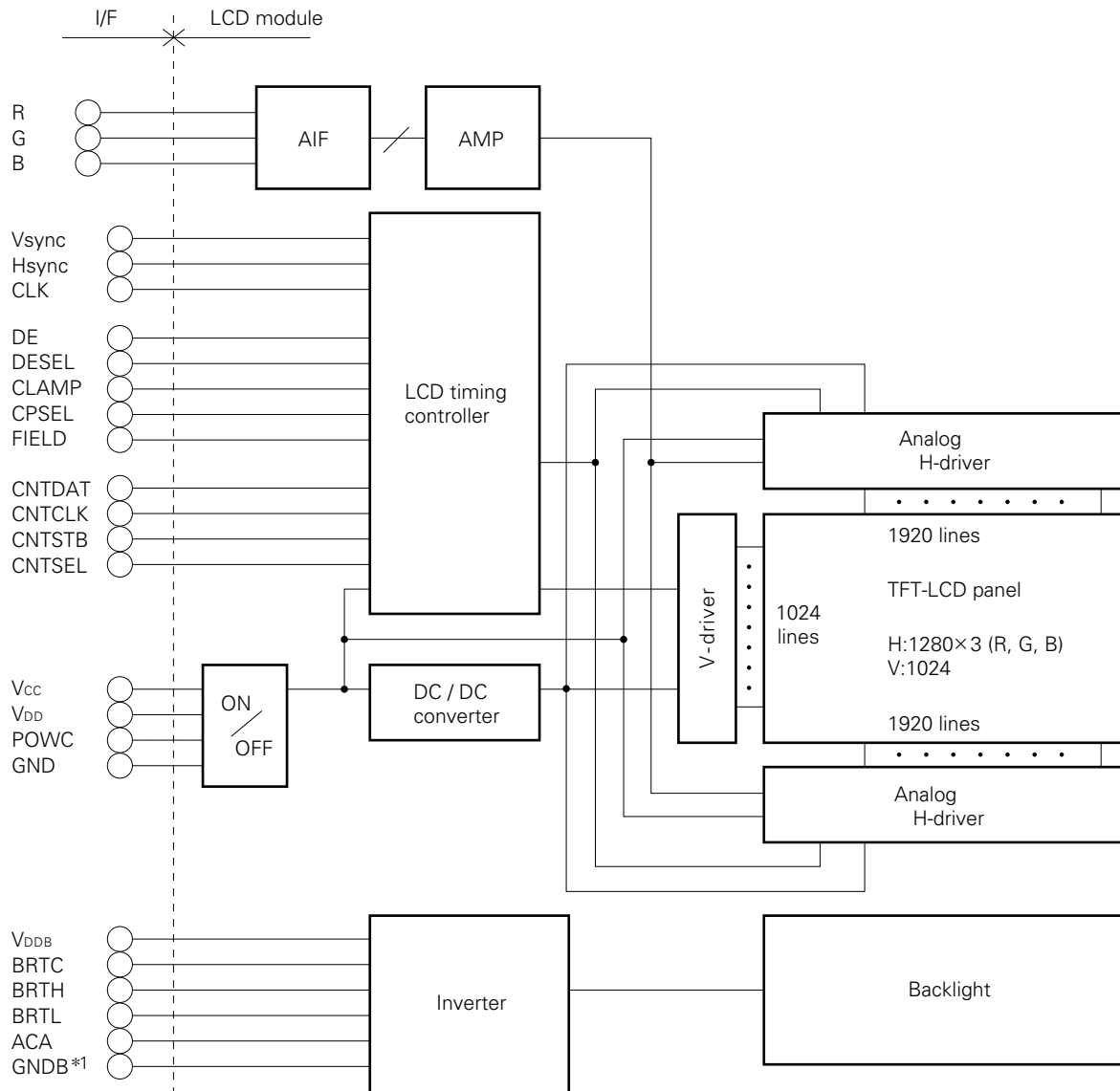

*1 GNDB is connected to the module frame ground.

OUTLINE OF CHARACTERISTICS (at room temperature)

Display area	257.3 (H)×205.8 (V)mm
Drive system	a-Si TFT active matrix
Display colors	Full-color
Number of pixels	1280×1024
Pixel arrangement	RGB vertical stripe
Pixel pitch	0.201 (H)×0.201 (V)mm
Module size	310.0 (H)× 255.0 (V)× 27.0 max. (D)mm
Weight	1150 g (typ.)
Contrast ratio	150:1 (typ.)
Viewing angle (more than the contrast ratio of 10:1)	
	• Horizontal: 45° (typ. left side, right side)
	• Vertical : 20° (typ. upper side), 25° (typ. lower side)
Designed viewing direction	
	• Wider viewing angle with contrast ratio : Down side (6 o'clock)
	• Wider viewing angle without image reversal : Up side (12 o'clock)
	• Optimum grayscale ($\gamma = 2.2$) : Perpendicular
Color gamut	40% (min., At center, To NTSC)
Response time	40 ms (max.), "white" to "black"
Luminance	200 cd/m ² (typ.)
Signal system	Analog RGB signals, Synchronous signals (Hsync, Vsync), Dot clock
Supply voltage	3.3 V, 12 V, 12 V
Backlight	Edge light type, Four cold cathode fluorescent lamps with inverter
Power consumption	21.3 W (typ.)

GENERAL SPECIFICATIONS

Item	Specifications	Unit
Module size	310.0±0.5(H) × 255.0±0.5(V) × 27.0 max. (D)	mm
Display area	257.28 (H) × 205.82 (V)	mm
Number of pixels	1280 (H) × 1024 (V)	pixel
Dot pitch	0.067 (H) × 0.201 (V)	mm
Pixel pitch	0.201 (H) × 0.201 (V)	mm
Pixel arrangement	RGB(Red, Green, Blue) vertical stripe	-
Display colors	Full-color	color
Weight	1200 (max.)	g

note : A variable resistor for the luminance control is extra.

ABSOLUTE MAXIMUM RATINGS

Parameter	Symbol	Ratings	Unit	Remarks
Supply voltage	V _{CC}	-0.3 to +4.6	V	Ta = 25°C
	V _{DD}	-0.3 to +14	V	
	V _{DBB}	-0.3 to +14	V	
Logic input voltage	V _{IN1}	-0.3 to +5.5	V	
R, G, B input voltage	V _{IN2}	-4.0 to +4.0	V	
CLK input voltage	V _{IN3}	-7.0 to +7.0	V	
Storage temp.	T _{st}	-20 to +60	°C	-
Operating temp.	T _{op}	0 to +50	°C	Module surface (note1)
Humidity	95% relative humidity		Ta ≤ 40°C	
	85% relative humidity		40°C < Ta ≤ 50°C	
	Absolute humidity shall not exceed Ta = 50°C, 85% relative humidity level.		Ta > 50°C	

note1: Measured at the display area

ELECTRICAL CHARACTERISTICS

(1) Logic/LCD driving/Backlight

Ta = 25°C

Parameter	Symbol	min.	typ.	max.	Unit	Remarks
Supply voltage	V _{CC}	3.0	3.3	3.6	V	for logic
	V _{DD}	11.4	12.0	12.6	V	for LCD driving
	V _{DDDB}	11.4	12.0	12.6	V	for backlight
Logic input "L" voltage	V _{IL}	0	-	0.8	V	TTL level
Logic input "H" voltage	V _{IH}	2.2	-	5.25	V	V _{CC} =3.3 V
Logic input "L" current 1	I _{IL1}	-1080	-	-	μA	for CNTSEL, CPSEL and POWC terminals
Logic input "H" current 1	I _{IH1}	-	-	10	μA	
Logic input "L" current 2	I _{IL2}	-600	-	-	μA	for BRTC terminal
Logic input "H" current 2	I _{IH2}	-	-	600	μA	
Logic input "L" current 3	I _{IL3}	-1000	-	-	μA	for ACA terminal
Logic input "H" current 3	I _{IH3}	-	-	1000	μA	
Logic input "L" current 4	I _{IL4}	-10	-	-	μA	except the above logic input terminals
Logic input "H" current 4	I _{IH4}	-	-	130	μA	
CLK input voltage	V _{CLK}	0.4 *1	-	1.0	V _{p-p}	for CLK
CLK DC input level	V _{dc-CLK}	-4.5	-	+4.5	V	
Supply current	I _{DDDB}	-	1050	1500	mA	V _{DDDB} = 12 V *2
	I _{DD}	-	530	900	mA	V _{DD} = 12 V *2
	I _{CC}	-	140	200	mA	V _{CC} = 3.3 V *2

*1 : Ta = 0 to 50°C : V_{CLK} = 0.6 V_{p-p} (MIN.).

Ta = 25°C : V_{CLK} = 0.4 V_{p-p} (MIN.).

*2 : dot-checked pattern

CLK input equivalent circuit

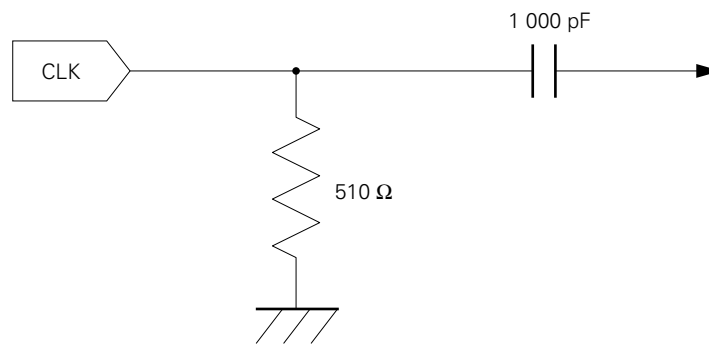

(2) Input video signals (R, G, B)

Ta = 25°C

Parameter	Symbol	min.	typ.	max.	Unit	Remarks
Video input voltages	V _{IRGB}	0 (black)	-	0.7 (white)	V _{p-p}	for RGB Zi = 75 Ω
Video input limits	V _{dc-RGB}	-2.5	-	+2.5	V	

SUPPLY VOLTAGE SEQUENCE

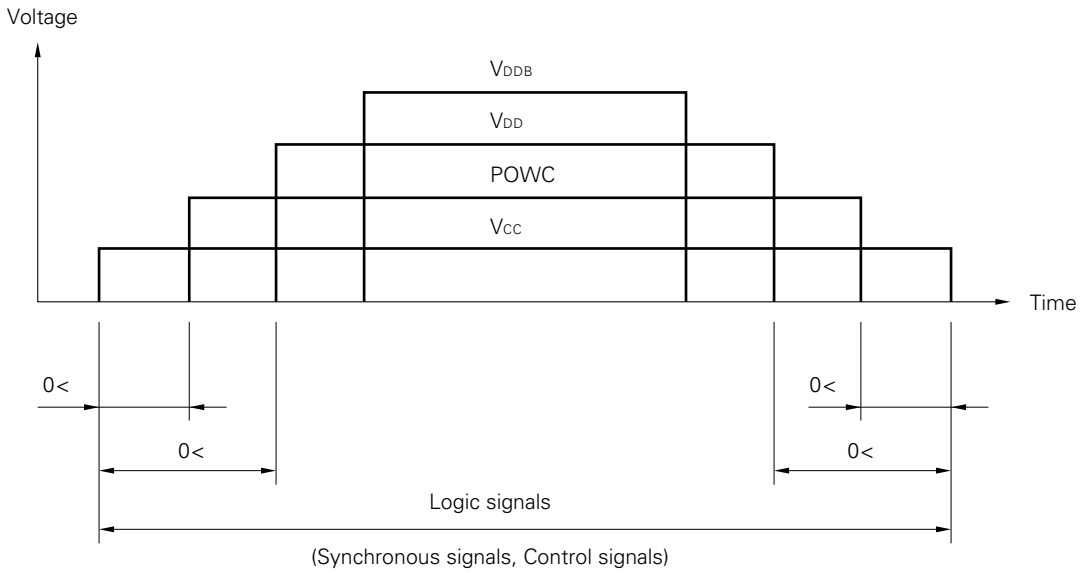

CAUTION
Wrong power sequence may damage the module.

- (1) Logic signals (synchronous signals and control signals) should be "0" voltage (V), when Vcc is not input. If higher than 0.3 V is input to signal lines, the internal circuit will be damaged.
- (2) LCD module will shut down the power supply of driving voltage to LCD panel internally, when one of CLK, Hsync, Vsync, DE (at DE mode) is not input more than 90 ms typically. During this period, the display data are unstable. But the backlight works correctly even this period, and the backlight can be controlled by BRTC signal.
- (3) The ON/OFF switching of backlight should operate while logic signals are supplied. If the backlight power supply (V_{DDb}) is turned ON / OFF without logic signals, unstable data will be displayed.
- (4) Keep POWC signal "L" more than 200 ms after the power supply (V_{cc}) is input, if POWC signal is controlled. (refer to PIN FUNCTION)
- (5) Analog RGB inputs are independent from this power supply sequence.
- (6) It is better for the timing between logic signals and V_{cc} as follows.

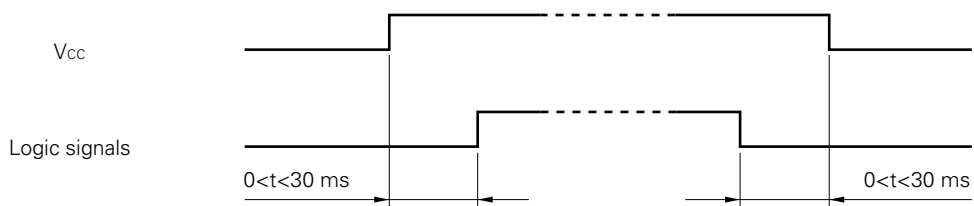

INTERFACE PIN CONNECTION

(1) Connector 1

CN1 : MRF03-6R-SMT (coaxial type)
 Adaptable socket : MRF03-2×6P-1.27 (For cable type) or
 MRF03-6PR-SMT (For board to board type)
 Supplier : HIROSE ELECTRIC CO., LTD.

Coaxial cable : UL20537PF75VLAS
 Supplier : HITACHI CO., LTD.

note : A coaxial cable shield should be connected with GND.

Pin No.	Symbol	Pin No.	Symbol
1	CLK	4	R
2	Hsync	5	G
3	Vsync	6	B

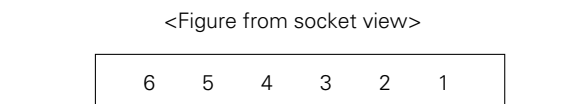

(2) Connector 2

CN2 : IL-Z-12PL1-SMTY
 Adaptable socket : IL-Z-12S-S125C3
 Supplier : Japan Aviation Electronics Industry Limited (JAE)

Pin No.	Symbol	Pin No.	Symbol
1	V _{DD}	7	V _{CC}
2	V _{DD}	8	V _{CC}
3	GND	9	DESEL
4	GND	10	GND
5	POWC	11	GND
6	GND	12	DE

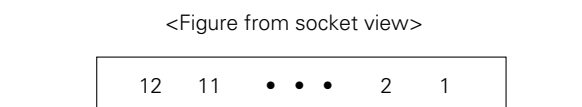

(3) Connector 3

CN3 : IL-Z-11PL1-SMTY
 Adaptable socket : IL-Z-11S-S125C3
 Supplier : Japan Aviation Electronics Industry Limited (JAE)

Pin No.	Symbol	Pin No.	Symbol
1	V _{DDB}	7	ACA
2	V _{DDB}	8	BRTC
3	V _{DDB}	9	BRTH
4	GNDB	10	BRTL
5	GNDB	11	N.C.
6	GNDB		

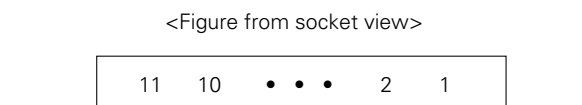

note : N.C. (No Connection) should be open.

(4) Connector 4

CN4 : IL-Z-13PL1-SMTY

Adaptable socket : IL-Z-13S-S125C3

Supplier : Japan Aviation Electronics Industry Limited (JAE)

Pin No.	Symbol	Pin No.	Symbol
1	GND	8	CLAMP
2	CNTSEL	9	GND
3	CNTDAT	10	FIELD
4	CNTSTB	11	GND
5	GND	12	N.C.
6	CNTCLK	13	GND
7	CPSEL		

<Figure from socket view>

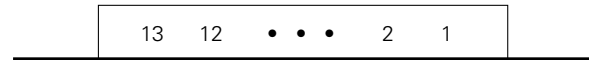

note : N.C. (No Connection) should be open.

<Connector location: Rear view>

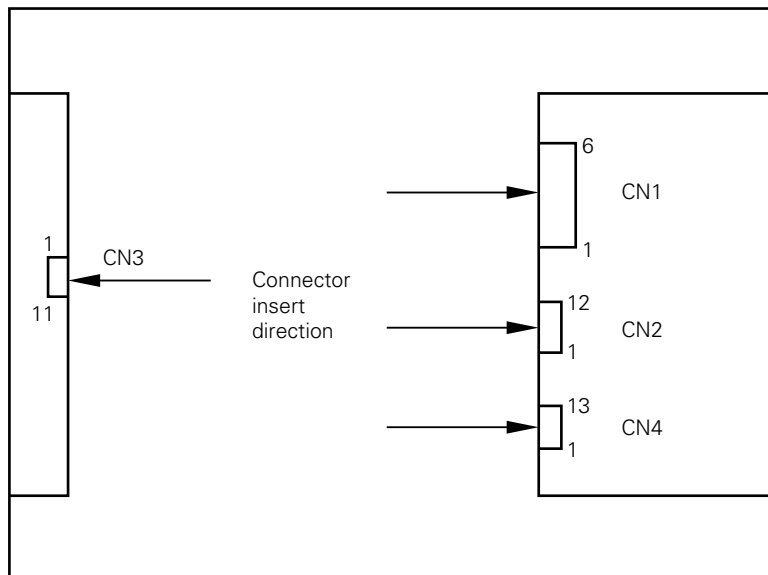

PIN FUNCTION

Symbol	Logic	Description
CLK	Positive	Dot clock input, timing signal for display data
Hsync	Negative	Horizontal synchronous signal input (TTL level)
Vsync	Negative	Vertical synchronous signal input (TTL level)
DE	Positive	Data enable signal input (TTL level) DE mode does not function at SXGA mode. Back-porch becomes free, when DESEL is "H". Back-porch becomes fix, when DESEL is "L". (DE should be fixed "H" or "L".)
R	–	Red video signal input (0.7 Vp-p, 75 Ω)
G	–	Green video signal input (0.7 Vp-p, 75 Ω)
B	–	Blue video signal input (0.7 Vp-p, 75 Ω)
CLAMP	–	Clamp timing signal of black level (TTL level) Valid for only CPSEL is "L".
CNTSEL	–	Display control signal in case of serial communication. (TTL level) H or open : Default L : External control
CNTDAT	Positive	Display control data (serial data) (TTL level)
CNTCLK	Positive	CLK for display control data (TTL level)
CNTSTB	Positive	Latch pulse for display control data (TTL level)
DESEL	Positive	DE function select signal (TTL level) H : DE mode L or open : Fixed mode
CPSEL	–	Clamp signal function select signal (TTL level) H or open : Default L : CLAMP signal is possible
POWC	Positive	Power control signal (TTL level) H or open : Logic, LCD power is on L : Logic, LCD power is off (note1)
BRTH/BRTL	–	Pins for backlight brightness control Connect 10 kΩ variable resistor (note2) or voltage control (note3).
BRTC	Positive	Backlight ON/OFF control signal H or open : Backlight on L : Backlight off
ACA	Positive	Luminance control signal H or open : Normal luminance L : Low luminance (1/2 of normal luminance)
Vcc	–	Vcc (+3.3 V) power supply for logic
VDD	–	VDD (+12 V ± 5%) power supply for LCD
VDDB	–	VDDB (+12 V ± 5%) power supply for backlight
GNDB		Ground for backlight (VDDB) GNDB is connected to the module frame ground.
GND	–	Signal ground for logic / LCD driving (Vcc, VDD) (Connect to a system ground.)

note1 :When POWC is "L" logic input signal should be all "0 V". If input signals are more than "0.3 V", inside circuits of the LCD module may be broken.

When POWC is "L", serial communication data is clear. Please set it again.

note2 :The variable resistor for brightness control should be 10 kΩ type, and zero point of the resistor corresponds to the minimum of luminance.

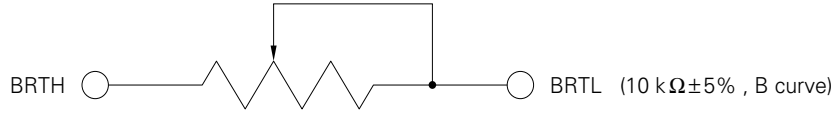

< connection of the variable resistor to pins >

note3 :In case of voltage control for brightness by BRTH/BRTL, at first, set BRTH to be "0 V". And BRTL input voltage can control the brightness. When BRTL input voltage is "1 V" the luminance become maximum. And when its voltage is "0 V", the luminance becomes minimum.

FUNCTIONS

(1) Serial data

This LCD module has following functions by serial data input (Table 1).

No.	FUNCTIONS	DETAIL
1	Expansion mode (Screen mode)	See Table 2 and EXPANSION FUNCTION
2	Display position control (HORIZONTAL)	See Table 6
3	Display position control (VERTICAL)	See Table 3
4	CLK delay control	See Table 4
5	Hsync period count number	See Table 7
6	CLK fall/rise synchronous change	See Table 5
7	Input frequency selection	See Table 8

HOW TO USE THE ABOVE FUNCTIONS

If CNTSEL is "L", the above functions are valid. (CNTSEL is "H" or open, default values are valid.) After serial data are transferred, the data is latched by CNTSTB. Once, the data is latched, the above functions are effective.

Please keep CNTSTB to be "L" during transferring data.

Input data can be changed during power on, but LCD display may be disturbed. When the serial data are changed, we recommend that the backlight power is off using BRTC function.

(2) Serial communication timing and waveform

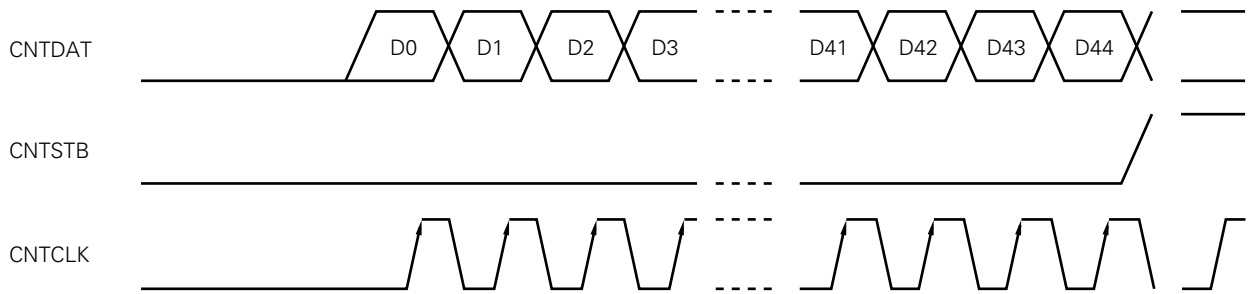

Parameter	Symbol	min.	max.	Unit	Remarks
CLK pulse width	twck	50	-	ns	CNTCLK
CLK frequency	fclk	-	5	MHz	
DATA setup-time	tdst	50	-	ns	CNTDAT
DATA hold-time	tdhl	50	-	ns	
Latch-pulse width	twlp	50	-	ns	CNTSTB
Latch setup-time	tlst	50	-	ns	
Rise / fall time	tr, tf	-	50	ns	CNT×××

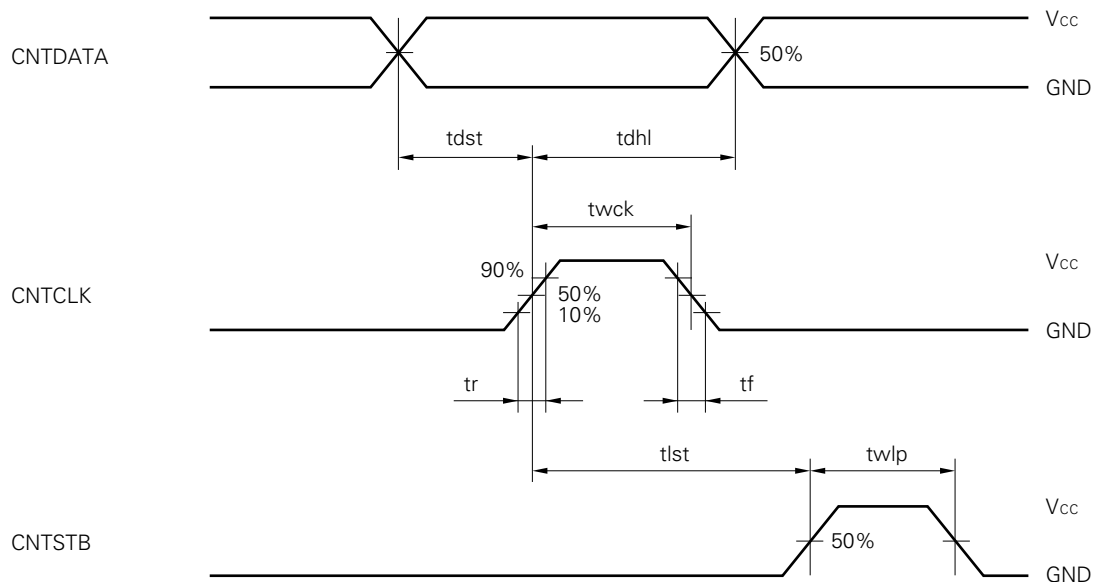

Table 1. CNTDAT COMPOSITION

Data	Data name	Function
D0	VEX3	Expansion mode See table 2
D1	VEX2	Expansion mode
D2	VEX1	Expansion mode
D3	VEX0	Expansion mode
D4	VD10	Vertical display position (MSB) See table 3
D5	VD9	Vertical display position
D6	VD8	Vertical display position
D7	VD7	Vertical display position
D8	VD6	Vertical display position
D9	VD5	Vertical display position
D10	VD4	Vertical display position
D11	VD3	Vertical display position
D12	VD2	Vertical display position
D13	VD1	Vertical display position
D14	VD0	Vertical display position (LSB)
D15	DELAY6	CLK delay (MSB) See table 4
D16	DELAY5	CLK delay
D17	DELAY4	CLK delay
D18	DELAY3	CLK delay
D19	DELAY2	CLK delay
D20	DELAY1	CLK delay
D21	DELAY0	CLK delay (LSB)
D22	CKS	CLK reverse signal See table 5
D23	HD8	Horizontal display position (MSB) See table 6
D24	HD7	Horizontal display position
D25	HD6	Horizontal display position
D26	HD5	Horizontal display position
D27	HD4	Horizontal display position
D28	HD3	Horizontal display position
D29	HD2	Horizontal display position
D30	HD1	Horizontal display position
D31	HD0	Horizontal display position (LSB)
D32	HSE10	Horizontal count number (MSB) See table 7
D33	HSE9	Horizontal count number
D34	HSE8	Horizontal count number
D35	HSE7	Horizontal count number
D36	HSE6	Horizontal count number
D37	HSE5	Horizontal count number
D38	HSE4	Horizontal count number
D39	HSE3	Horizontal count number
D40	HSE2	Horizontal count number
D41	HSE1	Horizontal count number
D42	HSE0	Horizontal count number (LSB)
D43	MOD1	CLK frequency select See table 8
D44	MOD0	CLK frequency select

MSB : Most Significant Bit

LSB : Least Significant Bit

Table 2. Display mode (VEX3 to VEX0 ; 4 bit)

VEX3	VEX2	VEX1	VEX0	Vertical magnification	Display mode	Display image
0	0	0	0	1	SXGA	Standard (note1) See DISPLAY IMAGE
0	0	0	1	1.25	XGA	
0	0	1	0	1.6	SVGA	
0	0	1	1	2.0	VGA	
0	1	0	0	2.5	PC98, VGA, TEXT	
0	1	0	1	-	Prohibit	
0	1	1	0	-	Prohibit	
0	1	1	1	4.0	NTSC	
1	0	0	X	-	Prohibit	
1	0	1	0	3.6	PAL	
1	0	1	1	-	Prohibit	
1	1	X	X	-	Prohibit	

note1 : Display mode is SXGA, when CNTSEL is "H" or "open".

Table 3. Vertical position (VD10 to VD0 ; 11 bit)

VD10	VD9	VD8	VD7	VD6	VD5	VD4	VD3	VD2	VD1	VD0	Vertical position [H] (note2)
0	0	0	0	0	0	0	0	0	0	0	Prohibit
0	0	0	0	0	0	0	0	0	0	1	Prohibit
0	0	0	0	0	0	0	0	0	1	0	Prohibit
0	0	0	0	0	0	0	0	0	1	1	Prohibit
0	0	0	0	0	0	0	0	1	0	0	4
0	0	0	0	0	0	0	0	1	0	1	5
.
.
.
1	1	1	1	1	1	1	1	1	0	1	2045
1	1	1	1	1	1	1	1	1	1	0	2046
1	1	1	1	1	1	1	1	1	1	1	2047 (note3)

note2 : This is horizontal line number for effecting VIDEO signal from Vsync-fall.

note3 : The maximum vertical position is Vsync total.

note4 : Vertical position is fixed at 47 H, when CNTSEL is "H" or "open".

Table 4. Clock (CLK) delay (DELAY6 to DELAY0 ; 7 bit)

DA (6 : 0) (note 5)	Delay value	DA (6 : 0) (note 5)	Delay value	DA (6:0) (note 5)	Delay value
00H	7.0 ns	2CH	33.3 ns	58H	59.2 ns
01H	7.6 ns	2DH	33.9 ns	59H	59.8 ns
02H	8.2 ns	2EH	34.4 ns	5AH	60.4 ns
03H	8.8 ns	2FH	35.1 ns	5BH	61.1 ns
04H	9.4 ns	30H	35.6 ns	5CH	61.6 ns
05H	10.0 ns	31H	36.2 ns	5DH	62.2 ns
06H	10.5 ns	32H	36.8 ns	5EH	62.7 ns
07H	11.2 ns	33H	37.5 ns	5FH	63.3 ns
08H	11.8 ns	34H	37.9 ns	60H	64.0 ns
09H	12.4 ns	35H	38.5 ns	61H	64.7 ns
0AH	13.0 ns	36H	39.1 ns	62H	65.3 ns
0BH	13.7 ns	37H	39.7 ns	63H	66.0 ns
0CH	14.2 ns	38H	40.4 ns	64H	66.5 ns
0DH	14.8 ns	39H	41.0 ns	65H	67.1 ns
0EH	15.3 ns	3AH	41.5 ns	66H	67.7 ns
0FH	15.9 ns	3BH	42.1 ns	67H	68.3 ns
10H	16.6 ns	3CH	42.6 ns	68H	68.9 ns
11H	17.2 ns	3DH	43.2 ns	69H	69.5 ns
12H	17.8 ns	3EH	43.8 ns	6AH	70.1 ns
13H	18.4 ns	3FH	44.4 ns	6BH	70.7 ns
14H	18.9 ns	40H	45.0 ns	6CH	71.2 ns
15H	19.5 ns	41H	45.6 ns	6DH	71.9 ns
16H	20.1 ns	42H	46.2 ns	6EH	72.4 ns
17H	20.7 ns	43H	46.8 ns	6FH	73.1 ns
18H	21.4 ns	44H	47.3 ns	70H	73.6 ns
19H	22.0 ns	45H	47.8 ns	71H	74.2 ns
1AH	22.6 ns	46H	48.4 ns	72H	74.8 ns
1BH	23.2 ns	47H	49.0 ns	73H	75.4 ns
1CH	23.8 ns	48H	49.6 ns	74H	75.9 ns
1DH	24.4 ns	49H	50.2 ns	75H	76.5 ns
1EH	24.9 ns	4AH	50.8 ns	76H	77.0 ns
1FH	25.6 ns	4BH	51.4 ns	77H	77.7 ns
20H	26.3 ns	4CH	51.9 ns	78H	78.3 ns
21H	26.9 ns	4DH	52.6 ns	79H	79.0 ns
22H	27.4 ns	4EH	53.1 ns	7AH	79.6 ns
23H	28.1 ns	4FH	53.7 ns	7BH	80.2 ns
24H	28.5 ns	50H	54.5 ns	7CH	80.8 ns
25H	29.1 ns	51H	55.0 ns	7DH	81.4 ns
26H	29.7 ns	52H	55.6 ns	7EH	81.9 ns
27H	30.3 ns	53H	56.3 ns	7FH	82.5 ns
28H	31.0 ns	54H	56.8 ns		
29H	31.6 ns	55H	57.4 ns		
2AH	32.2 ns	56H	57.9 ns		
2BH	32.8 ns	57H	58.5 ns		

note 5: DA (6:0) means Delay
6 (D15) to 0 (D21)

<EXAMPLE>

DA (6:0)=00H

↓

D15 16 17 18 19 20 21
0 0 0 0 0 0 0

DA (6 : 0) = 2AH

↓

D15 16 17 18 19 20 21
0 1 0 1 0 1 0

note 6 : Delay value is approximate.

note 7 : DA (6:0) is fixed at 00H, when CNTSEL is "H" or "open". This value is the upper limit by setting MOD as next page.

MOD1	MOD0	Upper limit of VD6 to VD0 CLK-delay setting (HEXADECIMAL)
0	0	Prohibit
0	1	59H
1	0	6BH
1	1	7FH

note 8 : This delay value is typical at $T_a = 25^\circ\text{C}$, $V_{CC} = 3.3\text{ V}$. By changing ambient temperature and power supply, the delay will be changed also.

See the following references.

- ① Variation of CLK delay by temperature drift. (as reference)

The temperature constant of CLK delay is $0.2\% / ^\circ\text{C}$.

Calculated example:

In case that delay time is 20 ns at $T_a = 25^\circ\text{C}$;

- (a) In case of T_a rising to 50°C .

Increase of delay time $\rightarrow (50^\circ\text{C}-25^\circ\text{C}) \times 0.002 \times 20\text{ ns} = +1\text{ ns}$

So, the total delay time is 21 ns at $T_a = 50^\circ\text{C}$.

- (b) In case of T_a falling to 0°C .

Decrease of delay time $\rightarrow (0^\circ\text{C}-25^\circ\text{C}) \times 0.002 \times 20\text{ ns} = -1\text{ ns}$

So, the total delay time is 19 ns at $T_a = 0^\circ\text{C}$.

- ② Variation of CLK delay time against V_{CC} voltage change. (as reference)

Increase of $35\% / \text{V}$ in case of rising from $V_{CC} = 3.3\text{ V}$.

Decrease of $48\% / \text{V}$ in case of falling from $V_{CC} = 3.3\text{ V}$.

Calculated example:

In case that delay time is 20 ns at $V_{CC} = 3.3\text{ V}$.

- (a) In case of V_{CC} rising to 3.6 V.

Decrease of delay time $\rightarrow (3.3\text{ V}-3.6\text{ V}) \times 0.35 \times 20\text{ ns} = -2.1\text{ ns}$

So, the total delay time is 17.9 ns at $V_{CC} = 3.6\text{ V}$.

- (b) In case of V_{CC} falling to 3.0 V.

Increase of delay time $\rightarrow (3.3\text{ V}-3.0\text{ V}) \times 0.48 \times 20\text{ ns} = +2.88\text{ ns}$

So, the total delay time is 22.88 ns at $V_{CC} = 3.0\text{ V}$.

Table 5. CLK reverse signal

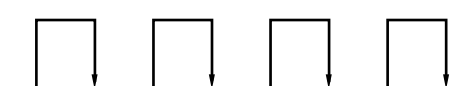
CKS	FUNCTION
0	<p>Data is sampled on rising edge of CLK.</p> 
1	<p>Data is sampled on falling edge of CLK.</p> 

note 9: CKS is "0", when CNTSEL is "H" or "open".

Table 6. Display horizontal position (HD8 to HD0; 9 bit)

HD8	HD7	HD6	HD5	HD4	HD3	HD2	HD1	HD0	Horizontal position [CLK] (note10)
0	0	0	0	0	0	0	0	0	Prohibit
0	0	0	0	0	0	0	0	1	Prohibit
•	•	•	•	•	•	•	•	•	•
•	•	•	•	•	•	•	•	•	•
0	0	1	1	0	1	1	0	1	Prohibit
0	0	1	1	0	1	1	1	0	110
0	0	1	1	0	1	1	1	1	111
•	•	•	•	•	•	•	•	•	•
•	•	•	•	•	•	•	•	•	•
1	1	1	1	1	1	1	0	1	509
1	1	1	1	1	1	1	1	0	510
1	1	1	1	1	1	1	1	1	511

note 10 : This is CLK number from Hsync-fall to effecting VIDEO signal.

note 11 : Horizontal position is set at 352 CLK, when CNTSET is "H" or "open".

Table 7. Display horizontal CLK numbers (HSE10 to HSE0; 11 bit)

HSE10	HSE9	HSE8	HSE7	HSE6	HSE5	HSE4	HSE3	HSE2	HSE1	HSE0	CLK number (note12)
0	0	0	0	0	0	0	0	0	0	0	0
0	0	0	0	0	0	0	0	0	0	1	1
0	0	0	0	0	0	0	0	0	1	0	2
0	0	0	0	0	0	0	0	0	1	1	3
0	0	0	0	0	0	0	0	1	0	0	4
•	•	•	•	•	•	•	•	•	•	•	•
•	•	•	•	•	•	•	•	•	•	•	•
•	•	•	•	•	•	•	•	•	•	•	•
1	1	1	1	1	1	1	1	1	0	1	2045
1	1	1	1	1	1	1	1	1	1	0	2046
1	1	1	1	1	1	1	1	1	1	1	2047

note 12 : This is from one falling edge of Hsync to the next Hsync.

note 13 : CLK number is set 1664 CLK, when CNTSEL is "H" or "open".

note 14 : Set HSE0 to 10 complying with CLK number of Hsync. If the setting value is different from actual input signal, it cause a malfunction.

Table 8. Setting of CLK frequency (MOD1 to MOD0; 2 bit)

MOD1	MOD0	CLK frequency [MHz]
0	0	90 to 135
0	1	65 to 90
1	0	50 to 65
1	1	20 to 50

note 15 : Set MOD0 and MOD1 complying with input CLK frequency.

note 16 : CLK frequency is set 90 to 135 MHz, when CNTSEL is "H" or "open".

EXPANSION FUNCTION

HOW TO USE EXPANSION FUNCTION AND SCREEN IMAGE

Expansion mode is a function to expand screen. For example, VGA signal has 640×480 pixels. But, if the display data can be expanded to 1.6 times vertically and horizontally, VGA screen image can be displayed fully on the screen of XGA resolution.

This LCD module has the function of expanding vertical direction as shown in Table 1. And expanding horizontal direction is possible by setting input CLK frequency which is equivalent to the magnification. It is necessary to make this CLK outside of this LCD module.

DISPLAY IMAGE of after two pages is display example, when DE function is default and HD and VD are set to most suitable frequency. And when DE function is used, HD and VD become default. Please adjust the display to the best position by DE signal.

Please adopt these modes after evaluating display quality, because of becoming bad display in some cases.

The followings show display magnifications for each mode.

Input display	Resolution	Magnification	
		Vertical	Horizontal note 1
SXGA	1280 × 1024	1	1
XGA	1024 × 768	1.25	1.25
SVGA	800 × 600	1.6	1.6
VGA	640 × 480	2.0	2.0
VGA TEXT	720 × 400	2.5	1.6
PC-9801	640 × 400	2.5	2.0
PAL	(Vertical 280 × 2) × 640	4.0	2.0
NTSC	(Vertical 240 × 2) × 640	3.6	2.0

note 1 : The horizontal magnification multiplies the input clock (CLK).

$$\text{Input CLK} = \text{system CLK} \times \text{horizontal magnification}$$

Example :

In case of SXGA, SVGA and PC-9801, CLK frequency can be decided as follows.

$$\text{SXGA} : (\text{system CLK (107.5 MHz)}) \times 1.0 = 107.5 \text{ MHz}$$

$$\text{SVGA} : (\text{system CLK (40.0 MHz)}) \times 1.6 = 64.0 \text{ MHz}$$

SETTING SERIAL DATA FOR EXPANSION

Input signal								Module serial-data setting		
Mode	CLK [MHz]	Hsync [kHz]	Vsync [Hz]	Horizontal		Vertical		HSE	HD	VD
				Count number [CLK]	DSP *	Count number [H]	DSP *			
				(A)	(B)	–	(C)	Calculation formula		
								(A) × Vertical magnitude	(B) × Horizontal magnitude	= (C)
SXGA	107.50	64.603	59.929	1664	352	1078	47	(A) × 1.0	(B) × 1.0	= (C)
	135.00	78.125	72.005	1728	384	1085	58			
XGA	65.000	48.363	60.004	1344	296	806	35	(A) × 1.25	(B) × 1.25	
	75.000	56.476	70.069	1328	280	806	35			
	79.000	58.088	72.980	1360	328	807	39			
	78.750	60.023	75.029	1312	272	800	31			
SVGA	36.000	35.156	56.25	1024	200	625	24	(A) × 1.6	(B) × 1.6	
	40.000	37.879	60.317	1056	216	628	27			
	50.000	48.077	72.188	1040	184	666	29			
	49.500	46.875	75.000	1056	240	666	24			
VGA	25.175	31.469	59.940	800	144	525	35	(A) × 2.0	(B) × 2.0	
	31.500	37.861	72.809	832	168	520	31			
	31.500	37.500	75.000	840	184	500	19			
	31.334	34.971	66.611	896	176	525	6			
VGA TEXT	28.322	31.469	70.087	900	153	449	37	(A) × 1.6	(B) × 1.6	
PC-9801	21.053	24.827	56.424	848	144	440	33	(A) × 2.0	(B) × 2.0	
	25.175	31.469	70.086	800	144	449	37			
PAL	25.000	15.625	50.00	–	256	312.5	9	1600	= (B)	
NTSC	25.197	15.734	59.94	–	256	262.5	9	1601	= (B)	

* : DSP = Display Start Period. DSP is the total of "pulse-width" and "back-porch".

note 1 : HD and VD are approximate values. Set HD and VD in case of adjusting display to the screen center.

note 2 : The pulse-width of Hsync, Vsync and back-porch are the same as XGA-mode. (Standard-mode).

note 3 : Detail of HSE is mentioned in CLK number of Table 7.

note 4 : Detail of HD is mentioned in horizontal position of Table 6.

note 5 : Detail of VD is mentioned in vertical position of Table 3.

DISPLAY IMAGE

(a) XGA MODE (1024 × 768)

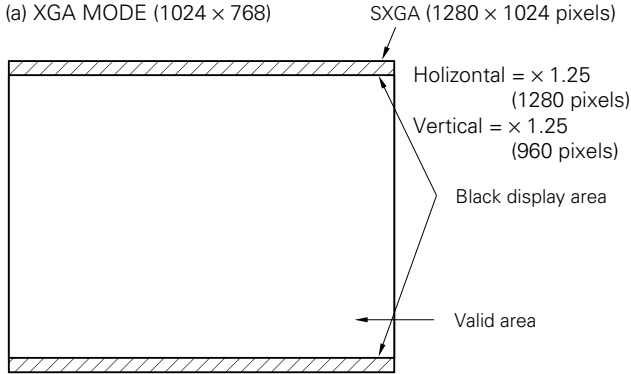

(e) VGA-TEXT MODE (720 × 400)

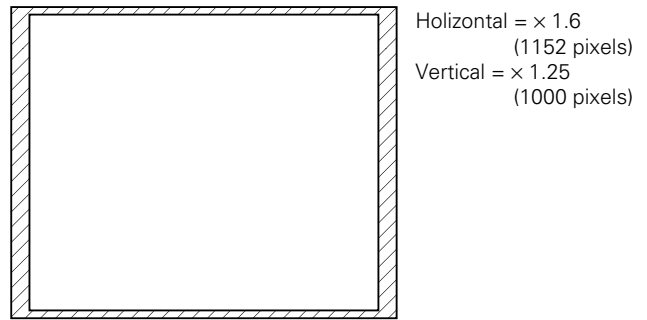

(b) SVGA MODE (800 × 600)

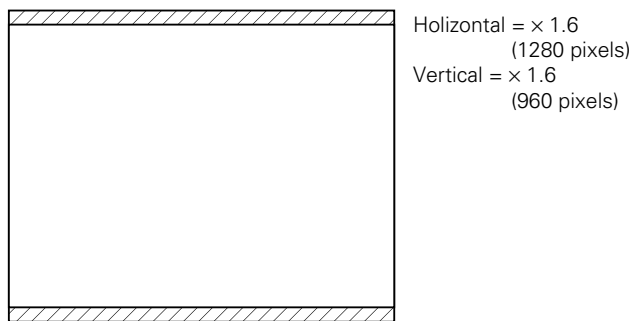

(f) PAL MODE (640 × (Ver. 280 × 2))

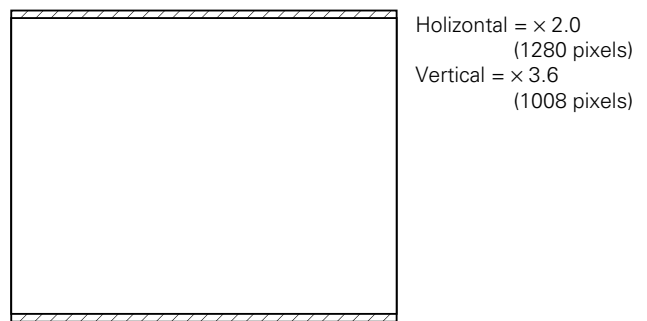

(c) VGA MODE (640 × 480)

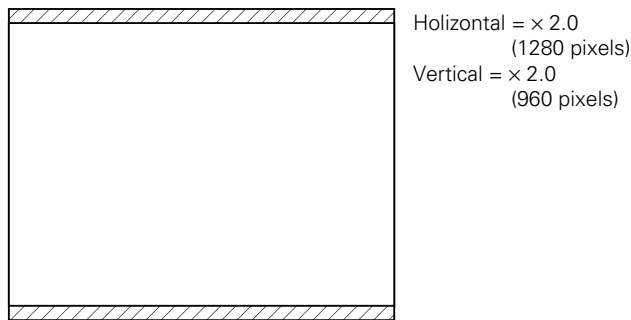

(g) NTSC MODE (640 × (Ver. 240 × 2))

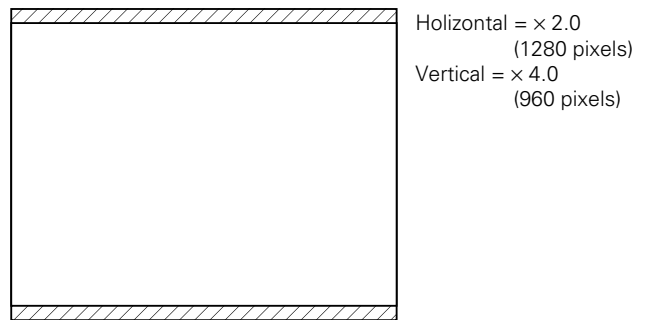

(d) 9801 MODE (640 × 400)

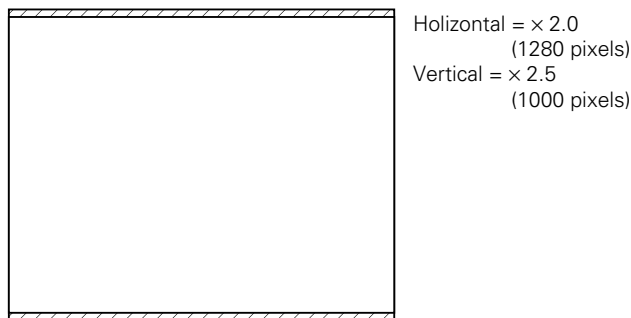

INPUT SIGNAL TIMING

(1) SXGA-MODE (Standard) – Without use serial communication (CNTSEL = "H" or OPEN)

Name		Symbol	min.	typ.	max.	Unit	Remarks
CLK	Frequency	1 / tc	95.0	107.5	135.0	MHz	SXGA standard
	Rise / fall	tcrf	-	9.3	-	ns	
	Duty	tch / tc	0.4	0.5	0.6	-	
Hsync	Period	th	12.8	15.479	17.0	μ s	64.603 kHz (typ.)
			-	1664	-	CLK	
	Display	thd	-	11.907	-	μ s	-
			-	1280	-	CLK	
	Front-porch	thf	-	0.289	-	μ s	-
			10	32	-	CLK	
	Pulse-width	thp	-	1.786	-	μ s	-
			16	192	-	CLK	
	Back-porch	thb	1.0	1.488	-	μ s	-
			94	160	-	CLK	
Pulse-width + Back-porch	thpb	1.8	-	-	μ s	-	
CLK-Hsync timing hold / setup time	thch	4.0	-	-	ns	-	
	thcs	2.0	-	-	ns	-	
V-Hsync timing hold / setup time	thvh	4.0	-	-	ns	-	
	thvs	1.0	-	-	CLK	-	
Rise / fall	thrf	-	-	10.0	ns	-	
Vsync	Period	tv	13.3	16.686	18.5	ms	59.929 Hz (typ.)
			-	1078	-	H	
	Display	tvd	-	15.850	-	ms	-
			-	1024	-	H	
	Front-porch	tvf	-	0.108	-	μ s	-
			1	7	-	H	
	Pulse-width	tvp	-	0.062	-	μ s	-
		2	4	-	H		
Back-porch	tvb	-	0.666	-	μ s	-	
		5	43	-	H		
Rise / fall	tvrf	-	-	10.0	ns	-	
Field timing	tfi	\pm 1	-	-	H	-	
DE	Setup time	tds	2.0	-	-	ns	-
	Hold time	tdh	4.0	-	-	ns	-
	Rise/fall	tdrf	-	-	10.0	ns	-
Analog RGB	tda	5.0	-	-	ns	-	

- Without use serial communication (CNTSEL = "H" or OPEN)

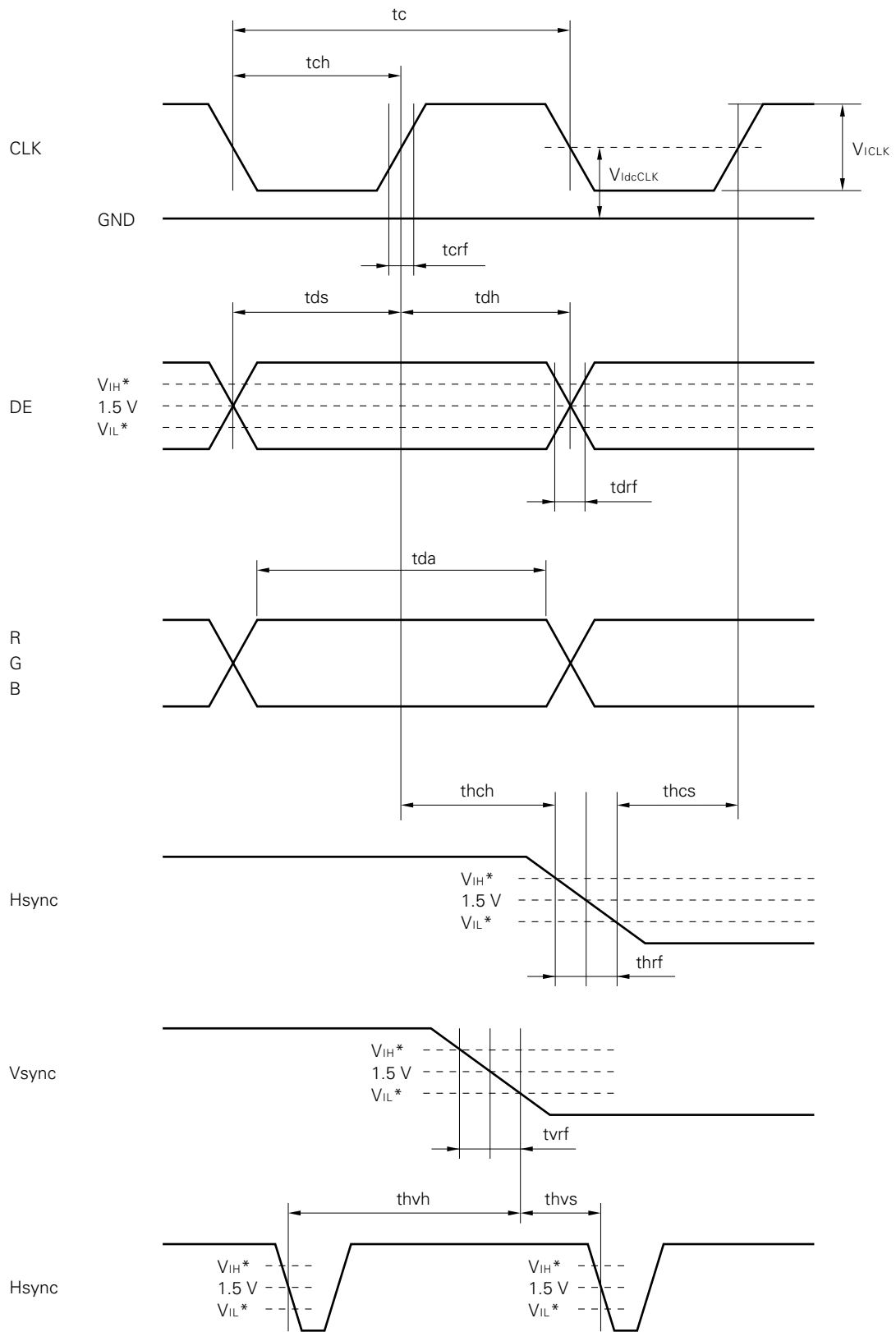

* V_{IH} = 2.2 V (min.) to 5.25 V (max.)
 V_{IL} = 0 V (min.) to 0.8 V (max.)

<Horizontal>

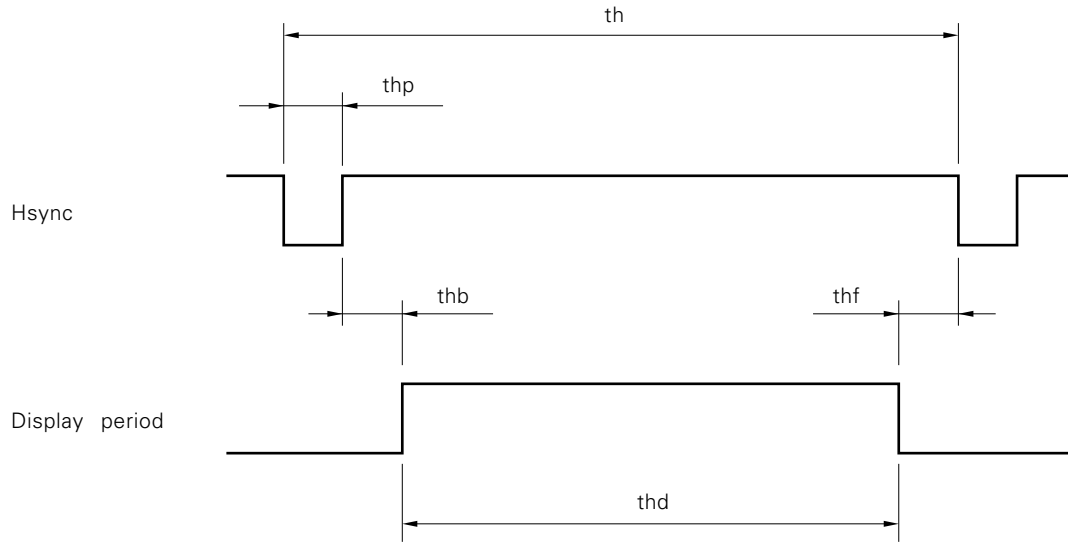

<Vertical>

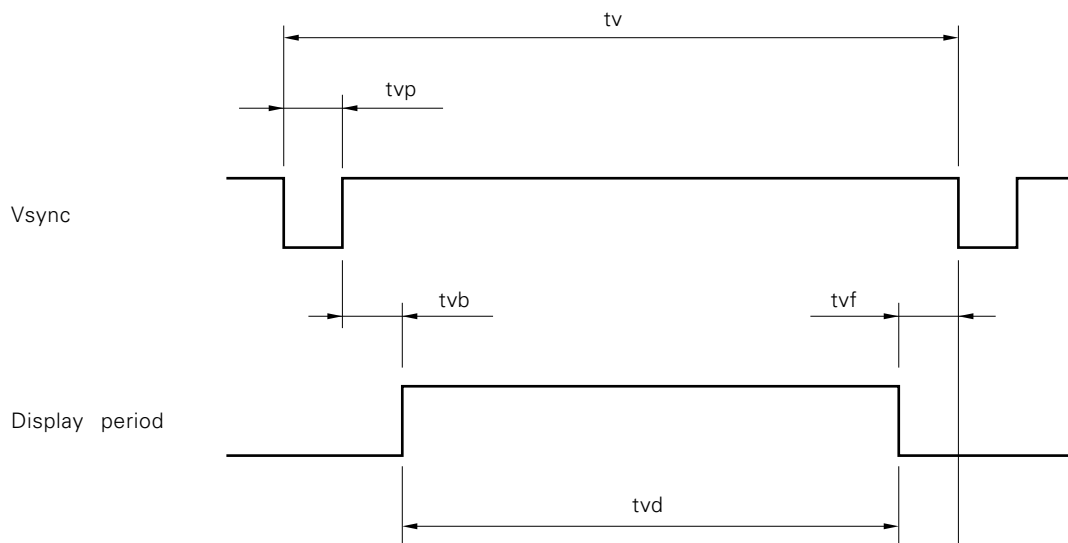

(NTSC/PAL)

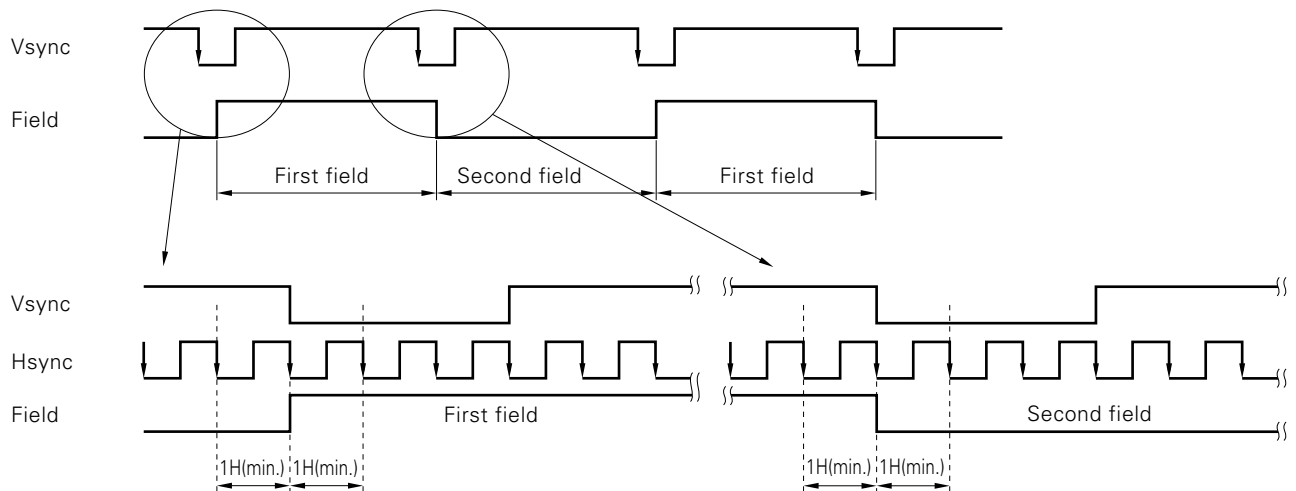

(2) Timing for generating CLAMP signal internally

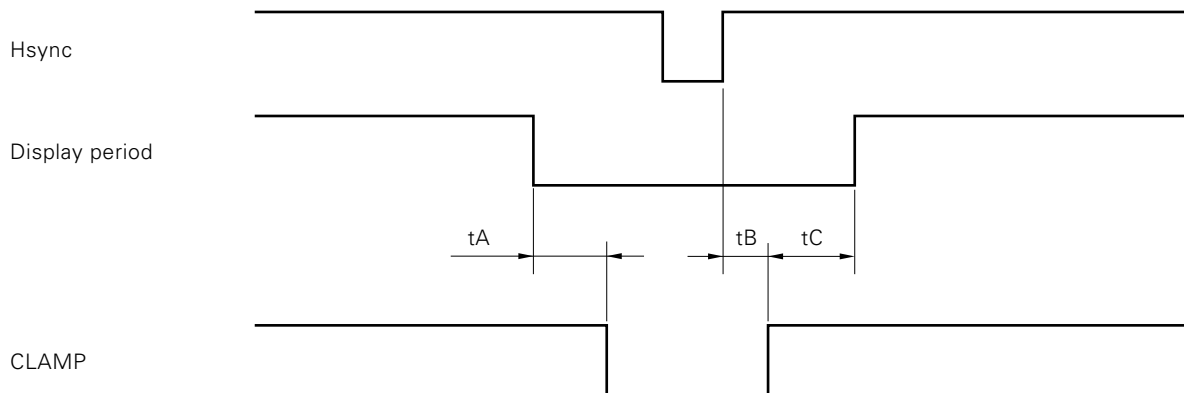

MOD1	MOD0	tA [CLK]	tB [CLK]	tC [ns]
0	0	62	46	200 min.
0	1	44	32	
1	0	34	22	
1	1	28	18	
NTSC/PAL		16	6	

note 1 : Exclude noises on analog RGB signal. Because during CLAMP = "L", the pedestal level of analog RGB signals is sampled. If noises are on the analog signals, luminance level of display is changed and the display becomes bad.

(3) Timing for inputting CLAMP signal from outside

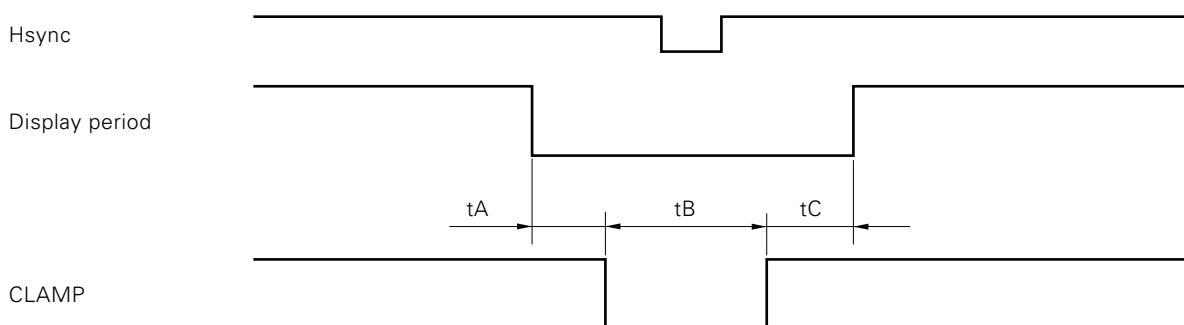

ITEMS	min.	typ.	max.	Unit	Remarks
tA	0.1	-	-	μs	-
tB	0.3	-	-	μs	-
tC	0.2	-	-	μs	-

note 2 : Exclude noises on analog RGB signal. Because during CLAMP = "L", the pedestal level of analog RGB signals is sampled. If noises are on the analog signals, luminance level of display is changed and the display becomes bad.

INPUT SIGNAL AND DISPLAY POSITION (SXGA STANDARD TIMING)

(1) DELSEL="L"

Pixels

D (0, 0)	D (0, 1)	D (0, 2)	• • •	• • •	D (0, 1280)
D (1, 0)	D (1, 1)				
D (2, 0)					
•					•
•					•
•					•
D (1023, 0)	D (1023, 1)	D (1023, 2)	• • •	• • •	D (1023, 1280)

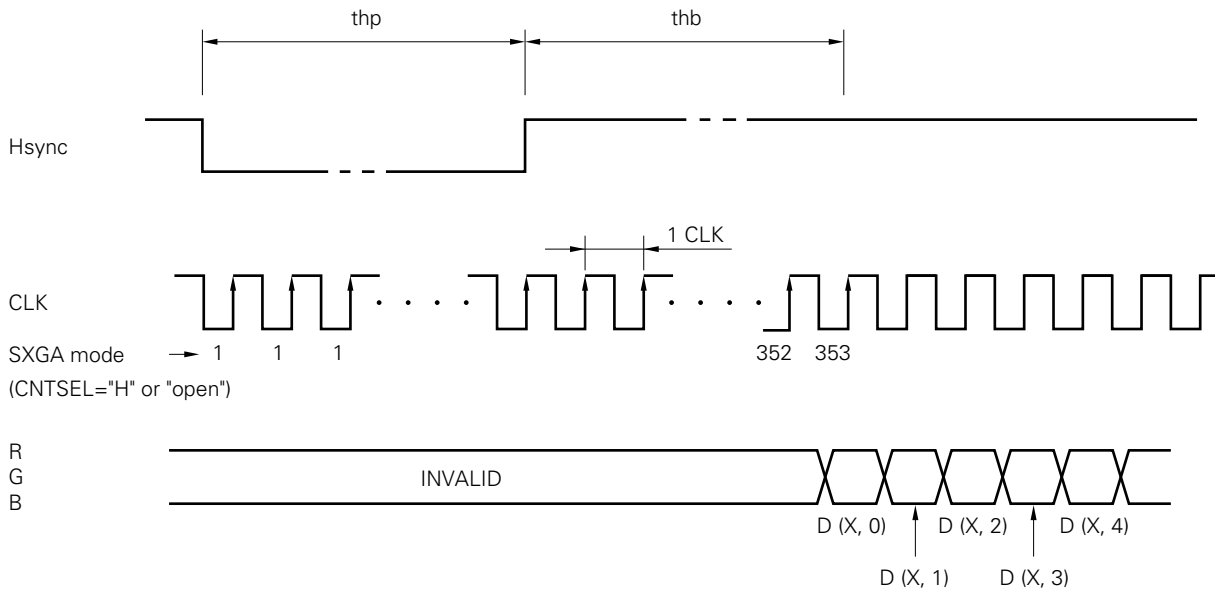
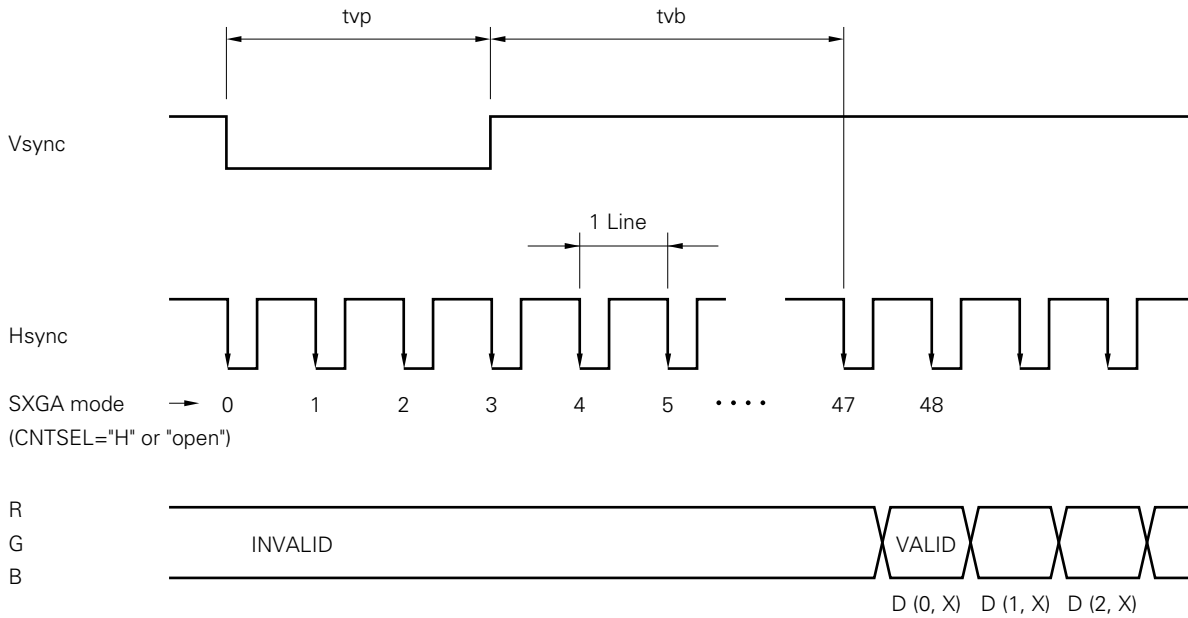

note 1 : The flat area of video signal should be more than 5 msec.

(2) DELSEL="H"

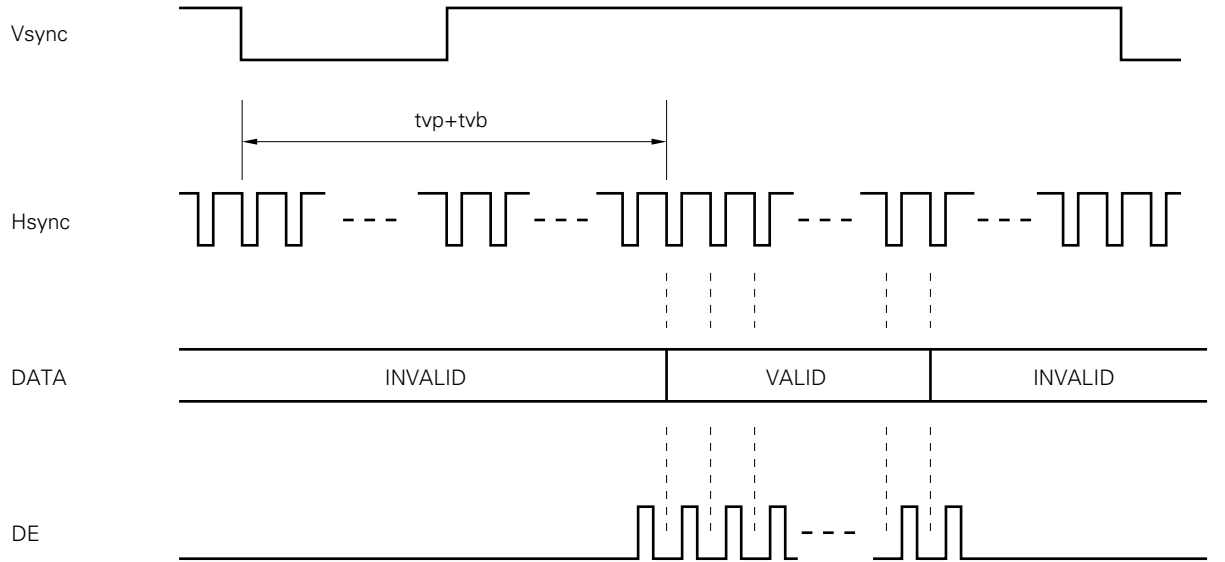
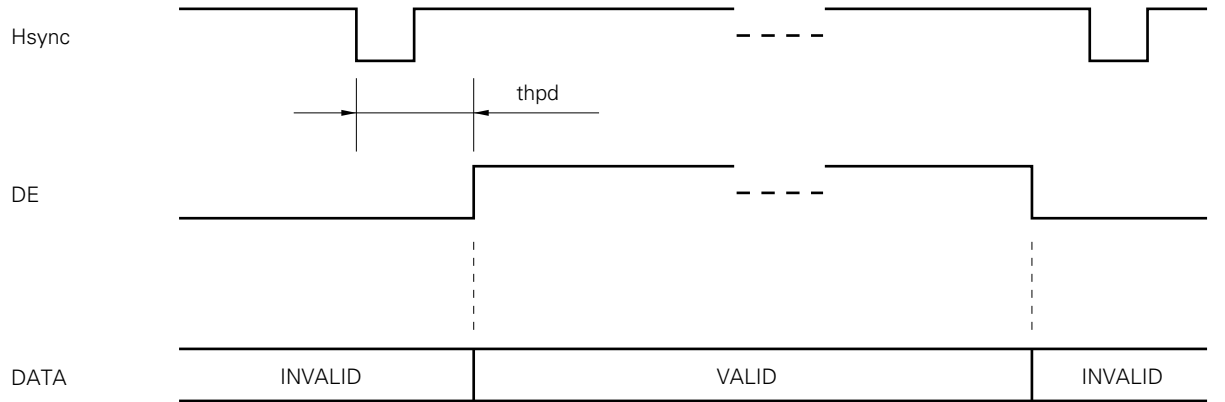
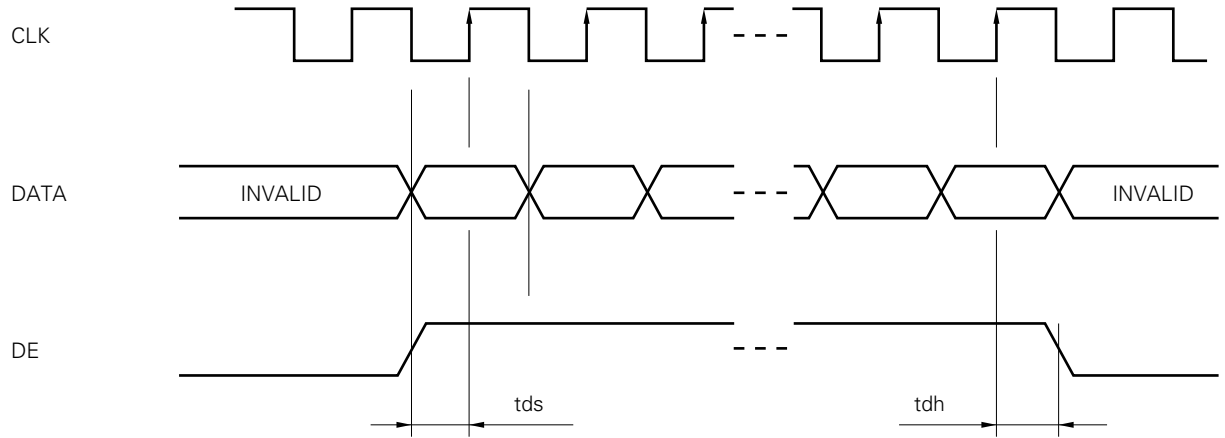

GENERAL CAUTION

WARNING

Do not touch an inverter --on which is stuck a caution label-- while the LCD module is under the operation, because of dangerous high voltage.

(1) Caution when taking out the module

- ① Pick the pouch only, when taking out module from a shipping package.

(2) Cautions for handling the module

- ① As the electrostatic discharges may break the LCD module, handle the LCD module with care. Peel a protection sheet off from the LCD panel surface as slowly as possible.
- ② As the LCD panel and back-light element are made from fragile glass material, impulse and pressure to the LCD module should be avoided.
- ③ As the surface of polarizer is very soft and easily scratched, use a soft dry cloth without chemicals for cleaning.
- ④ Do not pull the interface connectors in or out while the LCD module is operating.
- ⑤ Put the module display side down on a flat horizontal plane.
- ⑥ Handle connectors and cables with care.
- ⑦ The torque of mounting screw should be 0.392 N•m (4 kgf•cm) less.

(3) Cautions for the operation

- ① When the module is operating, do not lose CLK, Hsync, or Vsync signals. If any one of these signals is lost, the LCD panel would be damaged.
- ② Obey the supply voltage sequence. If wrong sequence is applied, the module would be damaged.
- ③ Connect the variable resistor or fixed resistor (10 k Ω or less) to the pin of BRTH and BRTL. If the resistors are not connected, the life of fluorescent lamp would be short.

(4) Cautions for the atmosphere

- ① Dew drop atmosphere should be avoided.
- ② Do not store and / or operate the LCD module in a high temperature and/or humidity atmosphere. Storage in an electro-conductive polymer packing pouch and under relatively low temperature atmosphere is recommended.

(5) Cautions for the module characteristics

- ① Do not apply fixed pattern data signal to the LCD module at product aging. Applying fixed pattern for a long time may cause image sticking.

(6) Other cautions

- ① Do not disassemble and / or reassemble LCD module.
- ② Do not re-adjust variable resistor or switch etc.
- ③ When returning the module for repair or etc., Please pack the module not to be broken. We recommend to use the original shipping packages.

Liquid Crystal Display has following specific characteristics. These are not defects or malfunction.
The display condition of LCD module may be affected by the ambient temperature.
The LCD module uses cold cathode tube for backlight. The optical characteristics, like luminance or uniformity, will change during life time.
Uneven brightness and/or small spots may be noticed depending on different display patterns.

OUTLINE DRAWING : Front View (Unit in mm)

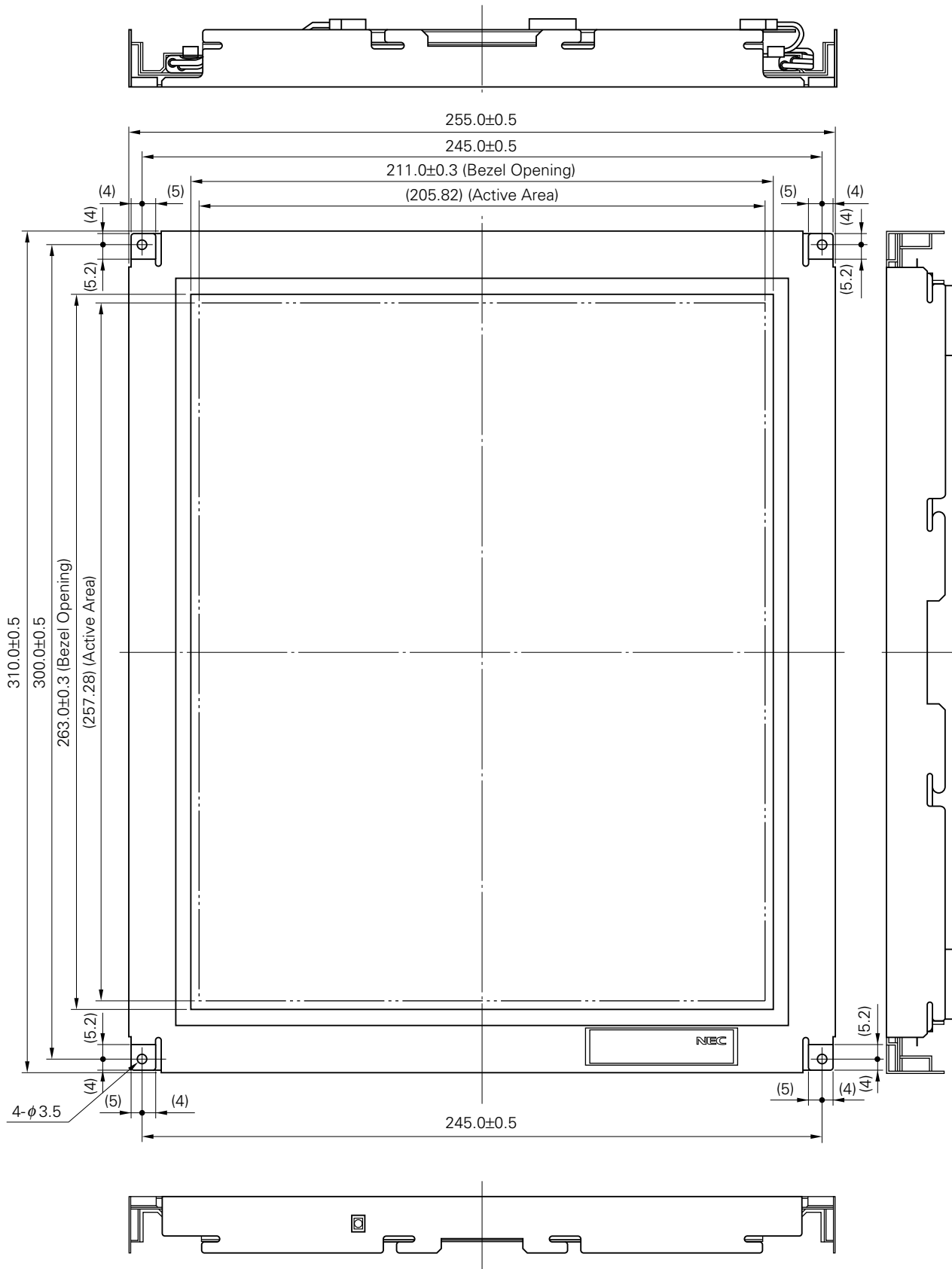

note 1 : The values in parentheses are for reference.

note 2 : The torque of mounting screw should be $0.392 \text{ N}\cdot\text{m}$ ($4 \text{ kgf}\cdot\text{cm}$) less.

OUTLINE DRAWING : Rear View (Unit in mm)

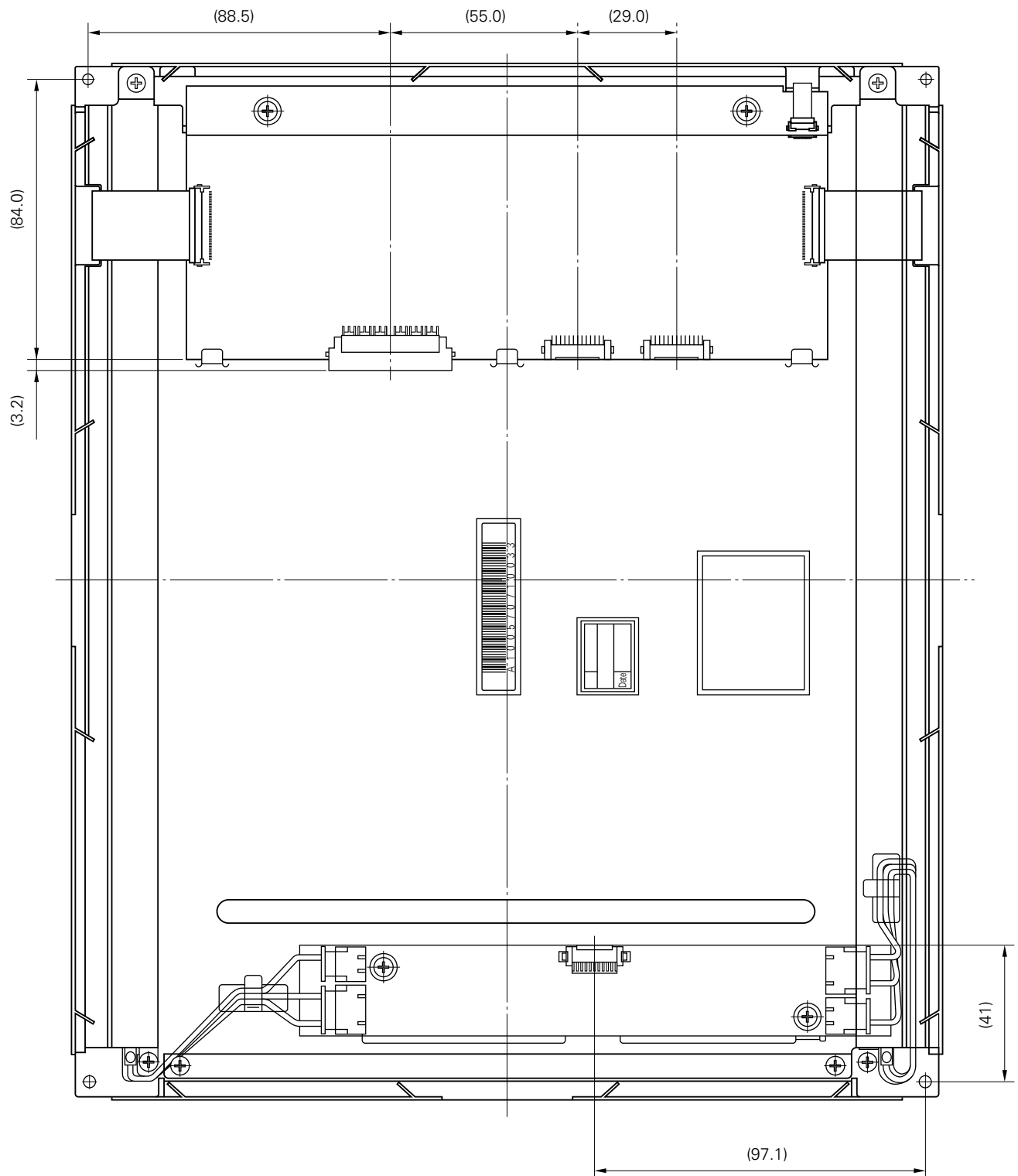

note 1 : The values in parentheses are for reference.

note 2 : The torque of mounting screw should be 0.392 N·m (4 kgf·cm) less.

No part of this document may be copied in any form or by any means without the prior written consent of NEC Corporation.

NEC Corporation does not assume any liability for infringement of patents, copyrights or other intellectual property rights of third parties by or arising from use of a device described herein or any other liability arising from use of such device. No license, either express, implied or otherwise, is granted under any patents, copyrights or other intellectual property rights of NEC Corporation or others.
