

NEC

TFT COLOR LCD MODULE

Type: NL10276AC30-04W
38cm (15.0 Type), XGA
LVDS interface (1 port)

Data sheet

(1st Edition)

All information is subject to change without notice.

Published by

1st Engineering Department
Color LCD Division
Display Device Operations Unit
NEC Electron Devices

INTRODUCTION

No part of this SPECIFICATIONS shall be copied in any form or by any means without the prior written consent of NEC Corporation.

NEC Corporation does not assume any liability for infringement of patents, copyrights or other intellectual property rights of third parties by or arising from use of a product described herein or any other liability arising from use of such application. No license, express, implied or otherwise, is granted under any patents, copyrights or other intellectual property rights of NEC Corporation or of others.

While NEC Corporation has been making continuous effort to enhance the reliability of its products, the possibility of failures cannot be eliminated entirely. To minimize risks of damage to property or injury to person arising from a failure in an NEC product, customers must incorporate sufficient safety measures in their design, such as redundancy, fire-containment and anti-failure features.

NEC products are classified into the following three quality grades:

"Standard", "Special", "Specific"

The *"Specific"* quality grade applies only to applications developed based on a customer designated "quality assurance program" for a specific application. The recommended applications of a product depend on its quality grade, as indicated below. Customers must check the quality grade of each application before using it in a particular application.

Standard: Computers, office equipment, communications equipment, test and measurement equipment, audio and visual equipment, home electronic appliances, machine tools, personal electronic equipment and industrial robots

Special: Transportation equipment (automobiles, trains, ships, etc.), traffic control systems, anti-disaster systems, anti-crime systems, safety equipment and medical equipment (not specifically designed for life support)

Specific: Military systems, aircraft, aerospace equipment, submersible repeaters, nuclear reactor control systems, life support systems (medical equipment, etc.) and any other equipment

The quality grade of this product is *"Standard"* unless otherwise specified in this SPECIFICATIONS. If customers intend to use this product for applications other than those specified for *"Standard"* quality grade, they should contact an NEC Corporation sales representative in advance.

Anti-radioactive design is not implemented in this product.

CONTENTS

INTRODUCTION	2
1. OUTLINE	4
1.1 STRUCTURE AND PRINCIPLE.....	4
1.2 APPLICATION.....	4
1.3 FEATURES.....	4
2. GENERAL SPECIFICATIONS	5
3. BLOCK DIAGRAM	6
4. DETAILED SPECIFICATIONS	7
4.1 MECHANICAL SPECIFICATIONS.....	7
4.2 ABSOLUTE MAXIMUM RATINGS.....	7
4.3 ELECTRICAL CHARACTERISTICS.....	8
4.3.1 Driving for LCD panel signal processing board.....	8
4.3.2 Driving for backlight inverter.....	8
4.3.3 Inverter current wave.....	9
4.3.4 Fuses.....	9
4.4 SUPPLY VOLTAGE SEQUENCE.....	10
4.4.1 Sequence for LCD panel signal processing board.....	10
4.4.2 Sequence for backlight inverter.....	10
4.5 CONNECTIONS AND FUNCTIONS FOR INTERFACE PINS.....	11
4.5.1 Positions of sockets.....	11
4.5.2 LCD panel signal processing board.....	11
4.5.3 Backlight inverter.....	12
4.6 LUMINANCE CONTROLS.....	13
4.6.1 Luminance control method.....	13
4.6.2 Detail of PWM timing.....	14
4.7 HOW TO CONNECT with LVDS TRANSMITTER.....	15
4.8 DISPLAY COLORS TO INPUT DATA SIGNALS.....	16
4.9 DISPLAY POSITIONS.....	17
4.10 INPUT SIGNAL TIMINGS.....	18
4.11 OPTICAL CHARACTERISTICS.....	21
4.11.2 Definition of contrast ratio.....	22
4.11.3 Definition of luminance uniformity.....	22
4.11.4 Definition of response times.....	22
4.11.5 Definition of viewing angles.....	22
5. RELIABILITY TESTS	23
6. PRECAUTIONS	24
6.1 MEANING OF CAUTION SIGNS.....	24
6.2 CAUTIONS.....	24
6.3 ATTENTIONS.....	24
7. OUTLINE DRAWINGS	27
7.1 Front view.....	27
7.2 Rear view.....	28
REVISION HISTORY	31

1. OUTLINE

1.1 STRUCTURE AND PRINCIPLE

NL10276AC30-04W module is composed of the driver LSIs for driving the TFT (Thin Film Transistor) array with an amorphous silicon thin film transistor liquid crystal display (a-Si TFT LCD) panel structure and a backlight.

The a-Si TFT LCD panel structure is injected liquid crystal material into the narrow gap between a TFT array glass substrate and a color filter glass substrate.

RGB (Red, Green, Blue) data signals from a source system are modulated into a form suitable for active matrix addressing by the onboard signal processor and sent to the driver LSIs which in turn address the individual TFT cells.

Working as an electro-optical switch, each TFT cell regulates transmitted light from the backlight assembly when worked by the data source. Color images are created by regulating the amount of transmitted light through the array of red, green and blue dots.

1.2 APPLICATION

- PC monitor

1.3 FEATURES

- LVDS interface
- Luminance
- High luminance
- Wide viewing angle (with Retardation Film)
- Low reflection
- High contrast ratio
- Wide color gamut
- Incorporated edge type backlight
- Replaceable lamp holder
- Approved by UL1950 Third Edition (File No. E170632) and CSA-C22.2 No. 950-95 (File No. E170632)

2. GENERAL SPECIFICATIONS

Display area	304.128 (H) × 228.096 (V) mm
Diagonal size of display	38 cm (15.0 inches)
Drive system	a-Si TFT active matrix
Display colors	262,144 colors
Number of pixels	1024 (H) × 768 (V) pixel
Pixel arrangement	RGB (Red, Green, Blue) vertical stripe
Dot pitch	0.099 (H) × 0.297 (V) mm
Pixel pitch	0.297 (H) × 0.297 (V) mm
Module size	350.0 (H) × 256.0 (V) × 23.1 Typ.(D) mm
Weight	1630 g (Typ.)
Contrast ratio	200:1 (Typ.)
Viewing angle (To be out of 10:1 for the contrast ratio)	<ul style="list-style-type: none"> • Horizontal: 65° (Typ. , left side, right side) • Vertical: 45° (Typ., up side), 50° (Typ., down side)
Designed viewing direction	<ul style="list-style-type: none"> • Optimum grayscale ($\gamma=2.2$): normal axis (perpendicular) • Viewing direction with contrast peak: down side 5° (6 o'clock)
Polarizer pencil-hardness	3H (Min., by JIS K5400)
Color gamut	<i>At LCD panel center</i> 56 % (Typ.) [against NTSC color space]
Response time	Ton =15 ms (Typ., 100% → 10%)
Luminance	330 cd/m ² (Typ.)
Signal system	LVDS interface (Receiver: THC63LVDF64A, THine Electronics, Inc. or equivalent) RGB 6-bit signals, Data enable signal (DE) and dot clock (CLK) encoded with THC63LVDF63A (THine Electronics, Inc.) are preferable.
Supply voltages	LCD panel signal processing board: 5V Backlight inverter: 12V
Backlight	Edge light type: 4 cold cathode fluorescent lamps in two holders and an inverter [Replaceable parts] <ul style="list-style-type: none"> • Backlight unit: 150LHS13 • Inverter: 150PW071
Power consumption	<i>At maximum luminance and checkered flag pattern</i> 16.5 W (Typ.)

3. BLOCK DIAGRAM

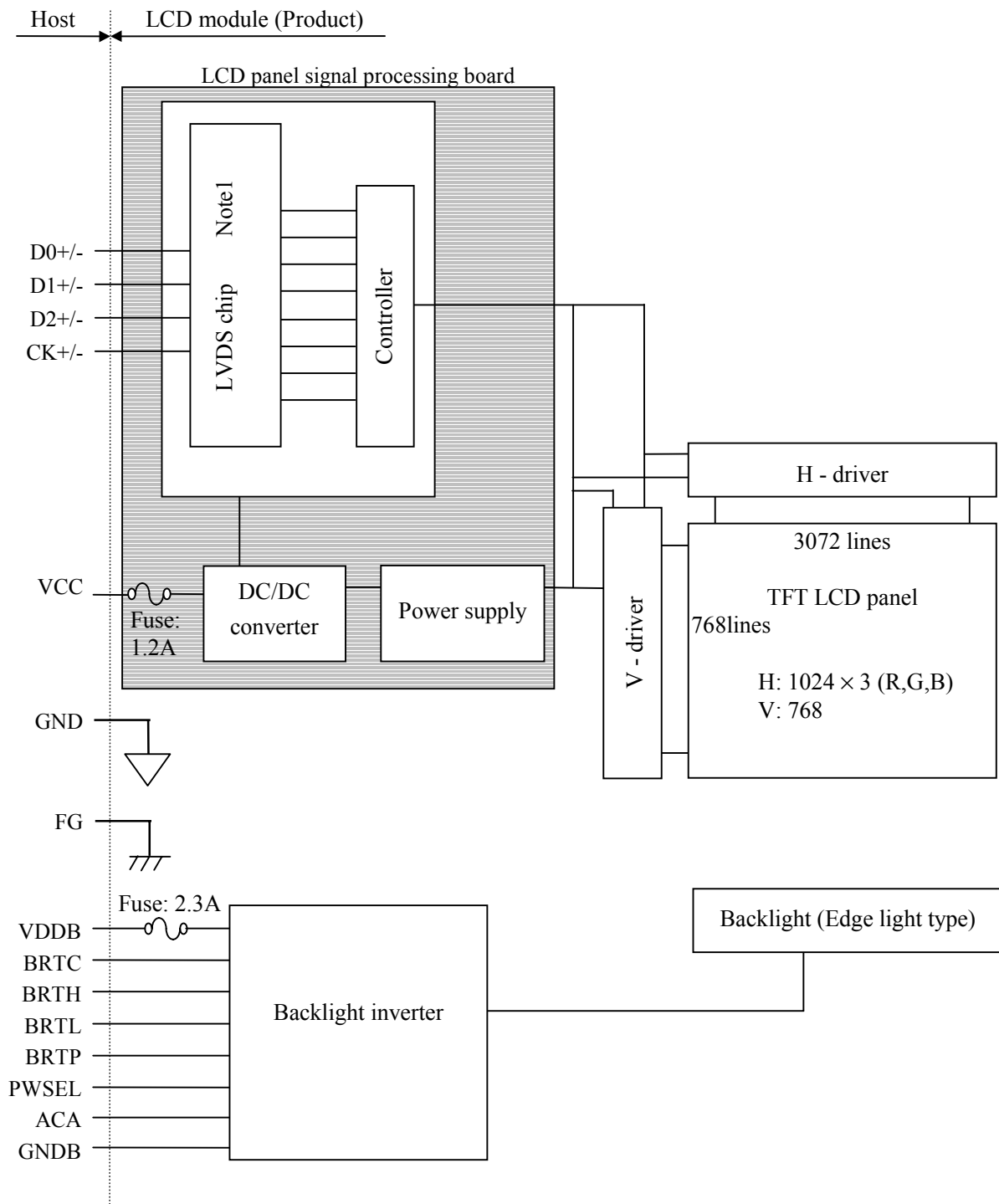

Note1: THC63LVDF64A, THine Electronics, Inc. or equivalent

Note2: Neither GND (Signal ground) nor GNDB (Backlight Ground) is connected to FG (Frame ground). These grounds should be connected to system ground in customer equipment.

4. DETAILED SPECIFICATIONS

4.1 MECHANICAL SPECIFICATIONS

Parameter	Specification	Unit
Module size	350.0 ± 0.6 (H) × 265.0 ± 0.6 (V) × 24.0 Max. (D) Note1	mm
Display area	304.128 (H) × 228.096 (V) Note1	mm
Weight	1,630 (Typ.), 1700 (Max.)	g

Note1: See "11.OUTLINE DRAWINGS".

4.2 ABSOLUTE MAXIMUM RATINGS

Parameters		Symbol	Rating	Unit	Remarks
Supply voltage	LCD panel signal board	VCC	-0.3 to +6.0	V	Ta = 25°C
	Inverter	VDDDB	-0.3 to +14.0	V	
Input voltage	Display signals Note1	Vi	-0.3 to VCC+0.3	V	Ta = 25°C
	BRTC	ViB1	-0.3 to +5.5	V	Ta = 25°C VDDDB=12V
	B RTP	ViB2	-0.3 to +5.5	V	
	PWSEL	ViB3	-0.3 to +5.5	V	
	ACA	ViB4	-0.3 to +5.5	V	
	BRTL	ViB5	-0.3 to +1.5	V	
Storage temperature		Tst	-20 to +60	°C	-
Operating temperature Note2		Top	0 to +50		
Relative humidity (RH) Note3			≤ 95	%	Ta ≤ 40°C
			≤ 85		40°C < Ta ≤ 50°C
Absolute humidity Note3			≤ 78 Note4	g/m ³	Ta > 50°C

Note1: Display signals are DE, CLK, R0 to R5, G0 to G5, B0 to B5

Note2: Measured at the LCD panel surface

Note3: No condensation

Note4: Ta = 50°C, RH = 85%

4.3 ELECTRICAL CHARACTERISTICS

4.3.1 Driving for LCD panel signal processing board

(Ta = 25°C)

Parameter	Symbol	Min.	Typ.	Max.	Unit	Remarks
Supply voltage	VCC	4.75	5.0	5.25	V	-
Supply current	ICC	-	300 Note1	600 Note2	mA	VCC=5.0V
Ripple voltage	VRP	-	-	+100	mV	for VCC
Differential input "L" Threshold voltage	VTL	-100	-	-	mV	at VCM=1.2V VCM: Common mode voltage in LVDS driver
Differential input "H" Threshold voltage	VTH	-	-	+100	mV	
Input voltage width	VI	0.25	0.35	0.45	V	RT=100Ω
Common mode voltage	VCM	1.125	1.25	1.375	V	RT=100Ω
Terminating resistor	RT	-	100	-	Ω	-

Note1: Checker flag pattern (in EIAJ ED-2522)

Note2: Theoretical maximum current pattern

4.3.2 Driving for backlight inverter

(Ta = 25°C)

Parameter	Symbol	Min.	Typ.	Max.	Unit	Remarks	
Supply voltage	VDDDB	10.8	12.0	13.2	V	Backlight power supply	
Supply current	Note1 IDDB	-	1230	1425	mA	VDDDB=12.0V (at Max. luminance)	
Logic input voltage	BRTC	ViB1L	0	-	0.8	V	-
		ViB1H	2.0	-	5.0	V	
	BRTP	ViB2L	0	-	0.8	V	-
		ViB2H	2.0	-	5.0	V	
	PWSEL	ViB3L	0	-	0.8	V	-
		ViB3H	2.0	-	5.0	V	
	ACA	ViB4L	0	-	0.8	V	-
		ViB4H	2.0	-	5.0	V	
Logic input current	BRTC	IiB1L	-610	-	-	μA	-
		IiB1H	-	-	440	μA	
	BRTP	IiB2L	-1580	-	-	μA	-
		IiB2H	-	-	3500	μA	
	PWSEL	IiB3L	-610	-	-	μA	-
		IiB3H	-	-	440	μA	
	ACA	IiB4L	-810	-	-	μA	-
		IiB4H	-	-	440	μA	
BRTL input current	BRTL	IiB5	-130	-	-	μA	-

4.3.3 Inverter current wave

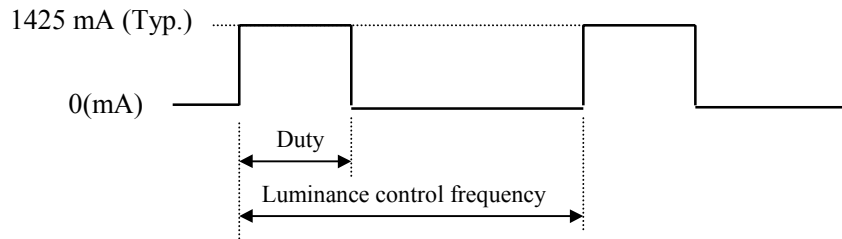

Maximum luminance control : 100% (Duty)

Minimum luminance control : 20% (Duty)

Luminance control frequency : 257.5 to 267.5Hz 262.5 Hz (Typ.)

Note 1: The power supply lines (VDDB and GNDB) have large ripple voltage while dimming. There is the possibility that the ripple voltage produces an acoustic noise and signal noise in a system circuit (e.g. audio circuit). If the noise occurred in a circuit system, put an aluminum electrolytic capacitor (5,000 to 6,000 μ F) between the power source lines (VDDB and GNDB), and the capacitor will be able to reduce the noise.

Note2: Luminance control frequency indicate the input pulse frequency, when select the external pulse control. See "**4.6.2 Detail of PWM timing**".

4.3.4 Fuses

This module has fuses listed below. Check and evaluate power supplies of customer's system.

Fuse		Rating Note1	Unit	Remarks
Type	Supplier			
ICP-S1.2	ROHM CO., LTD.	50	V	VCC (for LCD panel signal processing board)
		1.2	A	
ICTS2.3	ROHM CO., LTD.	50	V	VDDB (for backlight inverter)
		2.3	A	

Note1: The power capacity should be more than twice of fuse current ratings. If the power capacity is less than the criteria value, the fuse may not blow, and then nasty smell, smoking and so on may occur.

4.4 SUPPLY VOLTAGE SEQUENCE

4.4.1 Sequence for LCD panel signal processing board

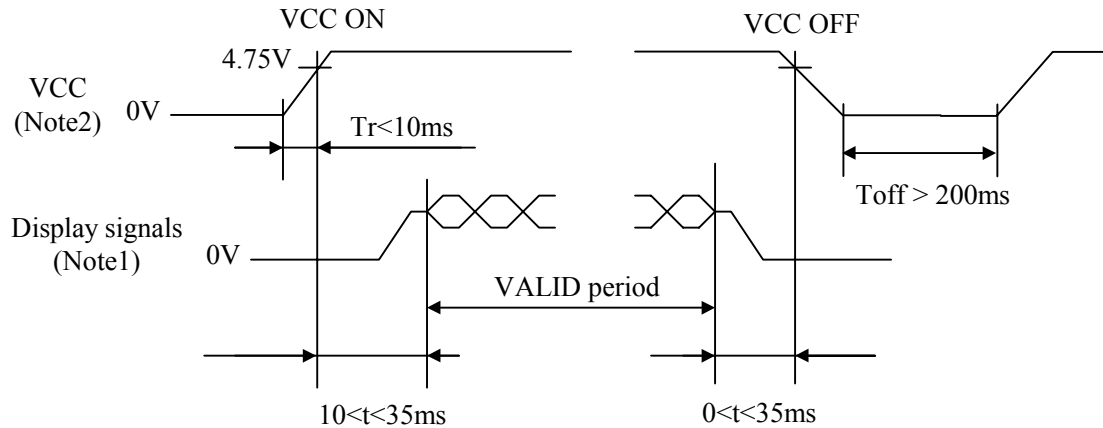

Note1: Display signals (DE, CLK, R0 to R5, G0 to G5, B0 to B5) must be "0" voltage (V), exclude the VALID period (See above sequence diagram). If input voltage to display signals is higher than 0.3V, the internal circuits might be damaged.

Note2: The values of signals are measured at the termination resistor of 100 ohm.

Note3: In terms of fall-off-potential while VCC leading edge is below 4.75V, protection circuits may work and then the module may not work.

Note4: If display signals to this module are cut while this module is working, even if the signal input to it once again, it may not work normally.

4.4.2 Sequence for backlight inverter

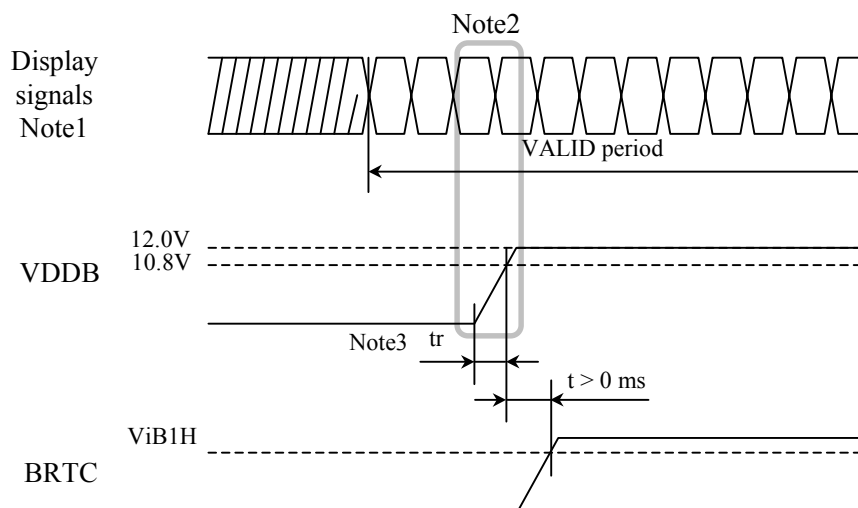

Note1: Display signals (DE, CLK, R0 to R5, G0 to G5, B0 to B5)

Note2: The backlight power voltage (VDDDB) should be inputted within the valid period of display signals, in order to avoid unstable data display.

Note3: The tr should be less than 800ms when BRTC terminal [Socket: CN202, Pin No.: 4] (See '4.5.2 Backlight inverter'.) is Open.

4.5 CONNECTIONS AND FUNCTIONS FOR INTERFACE PINS

4.5.1 Positions of sockets

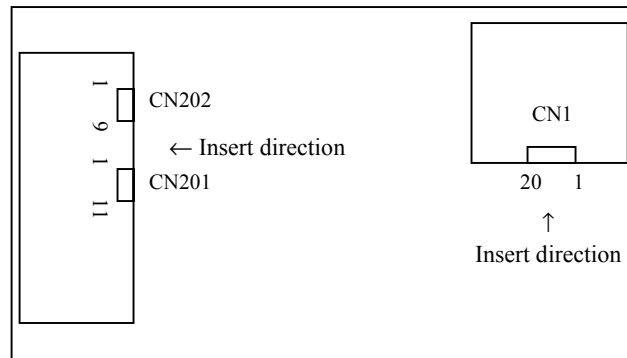

4.5.2 LCD panel signal processing board

CN1 socket: FI-SE20P-HF(LCD Module side)
 Adaptable plug: FI-SE-20M
 Supplier: Japan Aviation Electronics Industry Limited (JAE)

Pin No.	Symbol	Function	Description
1	GND	Ground	Connect to system ground.
2	GND		
3	N.C.	Non-connection	Keep the terminal open.
4	N.C.		
5	GND	Ground	Connect to system ground.
6	CK+	Pixel Clock	LVDS differential signal
7	CK-		
8	GND	Ground	Connect to system ground.
9	D2+	Pixel Data2	LVDS differential signal
10	D2-		
11	GND	Ground	Connect to system ground.
12	D1+	Pixel Data1	LVDS differential signal
13	D1-		
14	GND	Ground	Connect to system ground.
15	D0+	Pixel Data0	LVDS differential signal
16	D0-		
17	GND	Ground	Connect to system ground.
18	GND		
19	VCC	+5V Power Supply	5V±5%
20	VCC		

Note1: Use 100Ω twist pair wires for the cable.

CN1: Figure of socket

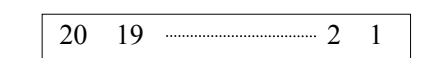

4.5.3 Backlight inverter

Select only one of the terminals of CN201 or CN202 about use of the terminal with the same function such as ACA, BRTC and BRTL!

CN201 socket: IL-Z-11PL1-SMTY (LCD Module side)

Adaptable plug: IL-Z-11S-S125C3

Supplier: Japan Aviation Electronics Industry Limited (JAE)

Pin No.	Symbol	Function	Description
1	VDDDB	+12V power supply	+12V±10%
2	VDDDB		
3	VDDDB		
4	GNDB	Backlight ground	Connect to system ground.
5	GNDB		
6	GNDB		
7	ACA	Luminance control by two step method	Note1
8	BRTC	Backlight ON/OFF control	“High” or “Open”: Backlight ON “Low”: Backlight OFF
9	BRTH	Luminance control resistor terminal	BRTH is connected to GNDB in the product Note1
10	BRTL	Luminance control by resistor method or voltage method	Note1
11	N.C.	Non-connection	Keep the terminal open.

Note1: See "4.6.1 Luminance control method".

CN201: Figure of socket

11 10 2 1

CN201 socket: IL-Z-9PL1-SMTY (LCD Module side)

Adaptable plug: IL-Z-9S-S125C3

Supplier: Japan Aviation Electronics Industry Limited (JAE)

Pin No.	Symbol	Function	Description
1	GNDB	Ground for backlight	Connect to system ground.
2	GNDB		
3	ACA	Luminance control by two step method	Note1
4	BRTC	Backlight ON/OFF control	“High” or “Open”: Backlight ON “Low”: Backlight OFF
5	BRTH	Luminance control resistor terminal	BRTH is connected to GNDB in the product Note1
6	BRTL	Luminance control by resistor method or voltage method	Note1
7	BRTP	PWM signal input	Note1
8	GNDB	Backlight ground	Connect to system ground.
9	PWSEL	Select signal of luminance control method	Note1

Note1: See "4.6.1 Luminance control method".

CN202: Figure of socket

9 8 2 1

4.6 LUMINANCE CONTROLS

4.6.1 Luminance control method

Method	Adjustment and luminance ratio	PWSEL signal	BRTP signal						
Resistor control Note1	<ul style="list-style-type: none"> Adjustment The variable resistor (R) for luminance control should be 10kΩ type, B curve and 1/10W. Minimum point of the resistor is the minimum luminance. Also maximum point of the resistor is the maximum luminance.  <ul style="list-style-type: none"> Luminance ratio Note3 <table border="1"> <thead> <tr> <th>Resistance</th> <th>Luminance ratio</th> </tr> </thead> <tbody> <tr> <td>0 kΩ</td> <td>25% (Minimum)</td> </tr> <tr> <td>10 kΩ</td> <td>100% (Maximum)</td> </tr> </tbody> </table>	Resistance	Luminance ratio	0 kΩ	25% (Minimum)	10 kΩ	100% (Maximum)	High or Open	Open
Resistance	Luminance ratio								
0 kΩ	25% (Minimum)								
10 kΩ	100% (Maximum)								
Voltage control Note1	<ul style="list-style-type: none"> Adjustment This control method can carry out continuation adjustment of luminance, if it is adjusted within the rated voltage for BRTL signal (ViB5). <ul style="list-style-type: none"> Luminance ratio Note3 <table border="1"> <thead> <tr> <th>BRTL Voltage (ViB5)</th> <th>Luminance ratio</th> </tr> </thead> <tbody> <tr> <td>0V</td> <td>25% (Minimum)</td> </tr> <tr> <td>1.0V</td> <td>100% (Maximum)</td> </tr> </tbody> </table>	BRTL Voltage (ViB5)	Luminance ratio	0V	25% (Minimum)	1.0V	100% (Maximum)		
BRTL Voltage (ViB5)	Luminance ratio								
0V	25% (Minimum)								
1.0V	100% (Maximum)								
Two step control	<ul style="list-style-type: none"> Adjustment This control method can carry out two step adjustment of luminance by ACA signal (ViB4). <ul style="list-style-type: none"> Luminance ratio Note3 <table border="1"> <thead> <tr> <th>ACA voltage (ViB4)</th> <th>Luminance ratio</th> </tr> </thead> <tbody> <tr> <td>Low (ViB4L) Note4</td> <td>50%</td> </tr> <tr> <td>High (ViB4H) Note4</td> <td>100%</td> </tr> </tbody> </table>	ACA voltage (ViB4)	Luminance ratio	Low (ViB4L) Note4	50%	High (ViB4H) Note4	100%		
ACA voltage (ViB4)	Luminance ratio								
Low (ViB4L) Note4	50%								
High (ViB4H) Note4	100%								
Pulse width modulation Note1 Note2 Note5	<ul style="list-style-type: none"> Adjustment Pulse width modulation (PWM) method works, when PWSEL signal is Low and PWM signal (BRTP signal) is inputted into BRTP terminal. The luminance is controlled by duty ratio of BRTP signal. <ul style="list-style-type: none"> Luminance ratio Note3 <table border="1"> <thead> <tr> <th>Duty ratio Note4</th> <th>Luminance ratio</th> </tr> </thead> <tbody> <tr> <td>0.2</td> <td>25% (Minimum)</td> </tr> <tr> <td>1.0</td> <td>100% (Maximum)</td> </tr> </tbody> </table>	Duty ratio Note4	Luminance ratio	0.2	25% (Minimum)	1.0	100% (Maximum)	Low	PWM signal
Duty ratio Note4	Luminance ratio								
0.2	25% (Minimum)								
1.0	100% (Maximum)								

Note1: In case of the resistor control method and the voltage control method, noises may appear on the display image depending on the input signals timing for LCD panel signal processing board.

Use PWM method, if interference noises appear on the display image!

Note2: In case BRTC signal is High or Open, the inverter will stop work when BRTP signal is fixed to Low. In this case, backlight will not turn on, even if BRTP signal is inputted again. This is not out of order. Backlight inverter will start to work when power is supplied again.

Note3: These data are the target values.

Note4: See '4.3.2 Driving for backlight inverter'.

Note5: See '4.6.2 Detail of PWM timing'.

4.6.2 Detail of PWM timing

(1) Timing diagrams

• Outline chart

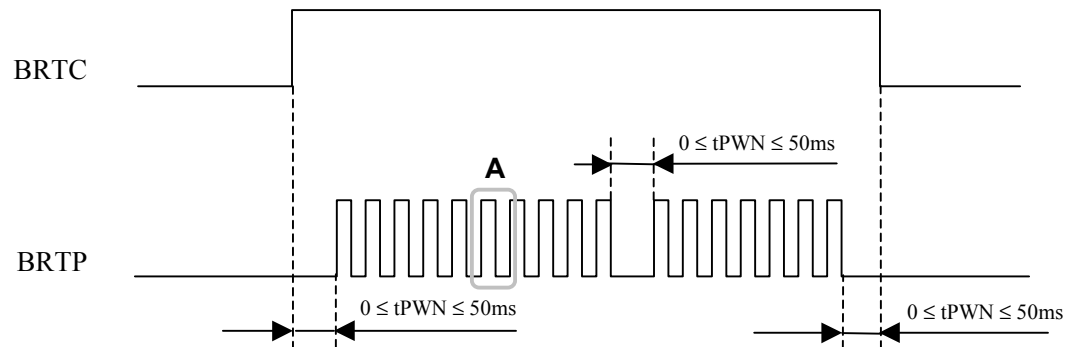

• Detail of A part

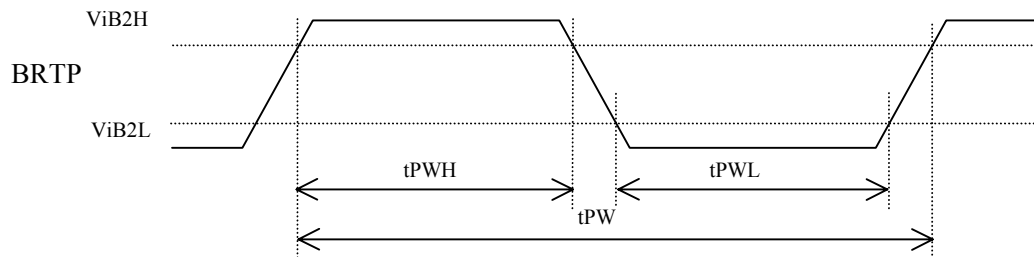

(2) Each parameter

Parameter	Symbol	Min.	Typ.	Max.	Unit	Remarks
Luminance control frequency	$1/t_{PW}$	185	-	340	Hz	Note1
Duty ratio	t_{PWH}/t_{PW}	0.2	-	1.0	-	Note2
Non signal period	t_{PWN}	0	-	50	ms	Note3

Note1: See the following formula for luminance control frequency.

$$\text{Luminance control frequency} = \text{tevc} \times (n+0.25) \text{ [or } (n + 0.75)\text{]}$$

$$n = 1, 2, 3 \dots \dots$$

tv: See '4.10 INPUT SIGNAL TIMINGS'.

The interference noise of luminance control frequency and input signal frequency for LCD panel signal processing board may appear on a display. Set up luminance control frequency so that the interference noise does not appear!

Note2: See '4.6.1 Luminance control methods'.

Note3: If t_{PWN} is more than 50ms, the backlight will be turned off by a protection circuit for inverter.

4.7 HOW TO CONNECT with LVDS TRANSMITTER

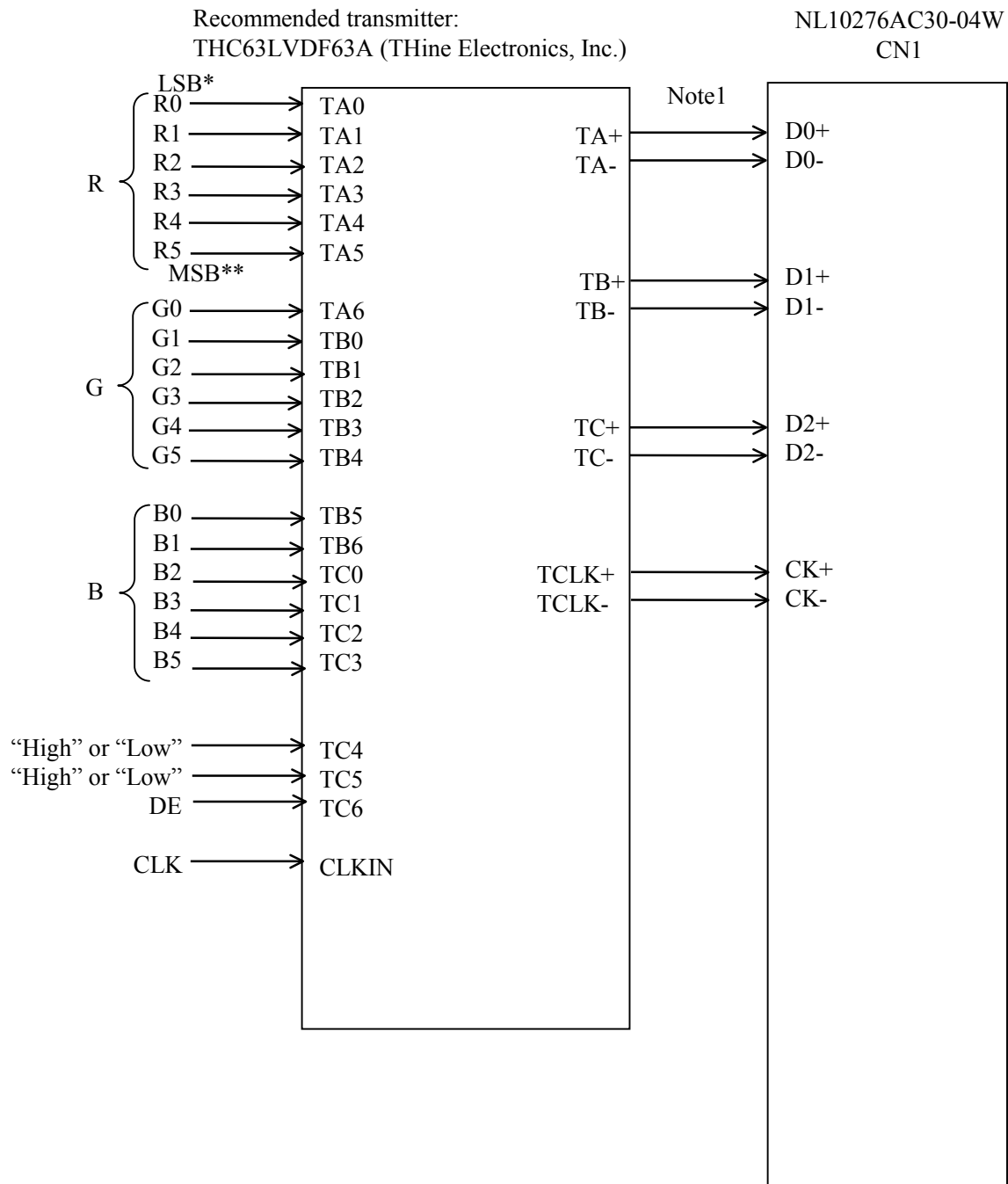

Note1: Use 100 Ω twist pair wires for the cable.

Note2: These signals should be kept the specification of **4.10 INPUT SIGNAL TIMINGS**.

Evaluate the clock jitter sufficiently, because the timing margins of LVDS signals are severe.

4.8 DISPLAY COLORS TO INPUT DATA SIGNALS

Display colors		Data signal (0: Low level, 1: High level)																	
		R5	R4	R3	R2	R1	R0	G5	G4	G3	G2	G1	G0	B5	B4	B3	B2	B1	B0
Basic Colors	Black	0	0	0	0	0	0	0	0	0	0	0	0	0	0	0	0	0	0
	Blue	0	0	0	0	0	0	0	0	0	0	0	1	1	1	1	1	1	1
	Red	1	1	1	1	1	1	0	0	0	0	0	0	0	0	0	0	0	0
	Magenta	1	1	1	1	1	1	0	0	0	0	0	1	1	1	1	1	1	1
	Green	0	0	0	0	0	0	1	1	1	1	1	1	0	0	0	0	0	0
	Cyan	0	0	0	0	0	0	1	1	1	1	1	1	1	1	1	1	1	1
	Yellow	1	1	1	1	1	1	1	1	1	1	1	1	0	0	0	0	0	0
	White	1	1	1	1	1	1	1	1	1	1	1	1	1	1	1	1	1	1
Red Grayscale	Black	0	0	0	0	0	0	0	0	0	0	0	0	0	0	0	0	0	0
	dark	0	0	0	0	0	1	0	0	0	0	0	0	0	0	0	0	0	0
	↑				:						:					:			
	↓				:						:					:			
	bright	1	1	1	1	0	1	0	0	0	0	0	0	0	0	0	0	0	0
	Red	1	1	1	1	1	0	0	0	0	0	0	0	0	0	0	0	0	0
Green Grayscale	Black	0	0	0	0	0	0	0	0	0	0	0	0	0	0	0	0	0	0
	dark	0	0	0	0	0	0	0	0	0	1	0	0	0	0	0	0	0	0
	↑				:					:						:			
	↓				:					:						:			
	bright	0	0	0	0	0	0	1	1	1	1	0	1	0	0	0	0	0	0
	Green	0	0	0	0	0	0	1	1	1	1	1	1	0	0	0	0	0	0
Blue Grayscale	Black	0	0	0	0	0	0	0	0	0	0	0	0	0	0	0	0	0	0
	dark	0	0	0	0	0	0	0	0	0	0	0	0	0	0	0	0	1	0
	↑				:					:						:			
	↓				:					:						:			
	bright	0	0	0	0	0	0	0	0	0	0	0	1	1	1	1	0	1	1
	Blue	0	0	0	0	0	0	0	0	0	0	0	1	1	1	1	1	1	0

Note1: The combination of 6-bit signals (64-grayscale level) results in 262,144 colors.

4.9 DISPLAY POSITIONS

C(0, 0)	C(1, 0)	•••	C(X, 0)	•••	C(1022, 0)	C(1023, 0)
C(0, 1)	C(1, 1)	•••	C(X, 1)	•••	C(1022, 1)	C(1023, 1)
• • •	• • •	• ••• •	• • •	• ••• •	• • •	• ••• •
C(0, Y)	C(1, Y)	•••	C(X, Y)	•••	C(1022, Y)	C(1023, Y)
• • •	• • •	• ••• •	• • •	• ••• •	• • •	• • •
C(0, 766)	C(0, 766)	•••	C(X, 766)	•••	C(1022, 766)	C(1023, 766)
C(0, 767)	C(1, 767)	•••	C(X, 767)	•••	C(1022, 767)	C(1023, 767)

4.10 INPUT SIGNAL TIMINGS

(1) Input signal specifications 1

Parameter		Symbol	Min.	Typ.	Max.	Unit	Remarks	
CLK	Frequency	1/tc	60.0	65.0	68.0	MHz	LVDS driver input	
			-	15.385	-	ns		
	Duty	tch/tc	Note2			-	-	
Period between rise and fall	trcf	ns						
DATA	CLK-DATA	Setup timing				tds		ns
		Hold timing	tdh	ns				
	Period between rise and fall	tdrf	ns					
DE	Horizontal	Cycle period	tehc	16.0	20.676	22.7	μ s	48.363kHz(Typ.)
			Note3	1110	1344	1780	CLK	
		Display period	tehd	1024			CLK	-
	Vertical (One frame)	Cycle period	tevc	13.3	16.666	18.5	ms	60.004kHz(Typ.)
				780	806	-	H	
		Display period	tevd	768			H	-
CLK-DE timing	Setup timing	tes	Note2			ns		
	Hold timing	teh				ns		
	Period between rise and fall	terf	ns					

Note1: Definition of units is as follows.

$$tc = 1\text{CLK}, tehc = 1\text{H}$$

Note2: Timing specifications are defined by the input signals of LVDS transmitter.

THC63LVDF63A (THine Electronics, Inc) or equivalent products are recommended for LVDS transmitter.

(2) Input signal specifications 2

Parameter	Symbol	Min.	Typ.	Max.	Unit	Remarks
CLK Frequency	TRCP	14.71	T	16.66	ns	-
Bit0 position	TRIP1	-0.5	0	+0.5	ns	T= 15.38ns
Bit1 position	TRIP0	T/7-0.5	T/7	T/7+0.5	ns	T= 15.38ns
Bit2 position	TRIP6	2T/7-0.5	2T/7	2T/7+0.5	ns	T= 15.38ns
Bit3 position	TRIP5	3T/7-0.5	3T/7	3T/7+0.5	ns	T= 15.38ns
Bit4 position	TRIP4	4T/7-0.5	4T/7	4T/7+0.5	ns	T= 15.38ns
Bit5 position	TRIP3	5T/7-0.5	5T/7	5T/7+0.5	ns	T= 15.38ns
Bit6 position	TRIP2	6T/7-0.5	6T/7	6T/7+0.5	ns	T= 15.38ns

Note1: See the specifications of LVDS manufactures for detailed design.

In case that CLK jitter value between current cycle and next cycle is big, skew time of the next cycle decreases with the value of the jitter.

$$\text{CLK jitter} + \text{LVDS output skew} + \text{cable skew} \leq 500\text{ps}$$

$$\left. \begin{array}{l} \text{e. g.: LVDS output skew: } \pm 200\text{ps} \\ \text{Cable skew: } \pm 100\text{ps} \end{array} \right\} \text{ acceptable CLK jitter } \pm 200\text{ps} \text{ (} 500 - (200 + 100) = 200\text{ps)}$$

(3) Input signal timing chart

- Outline chart

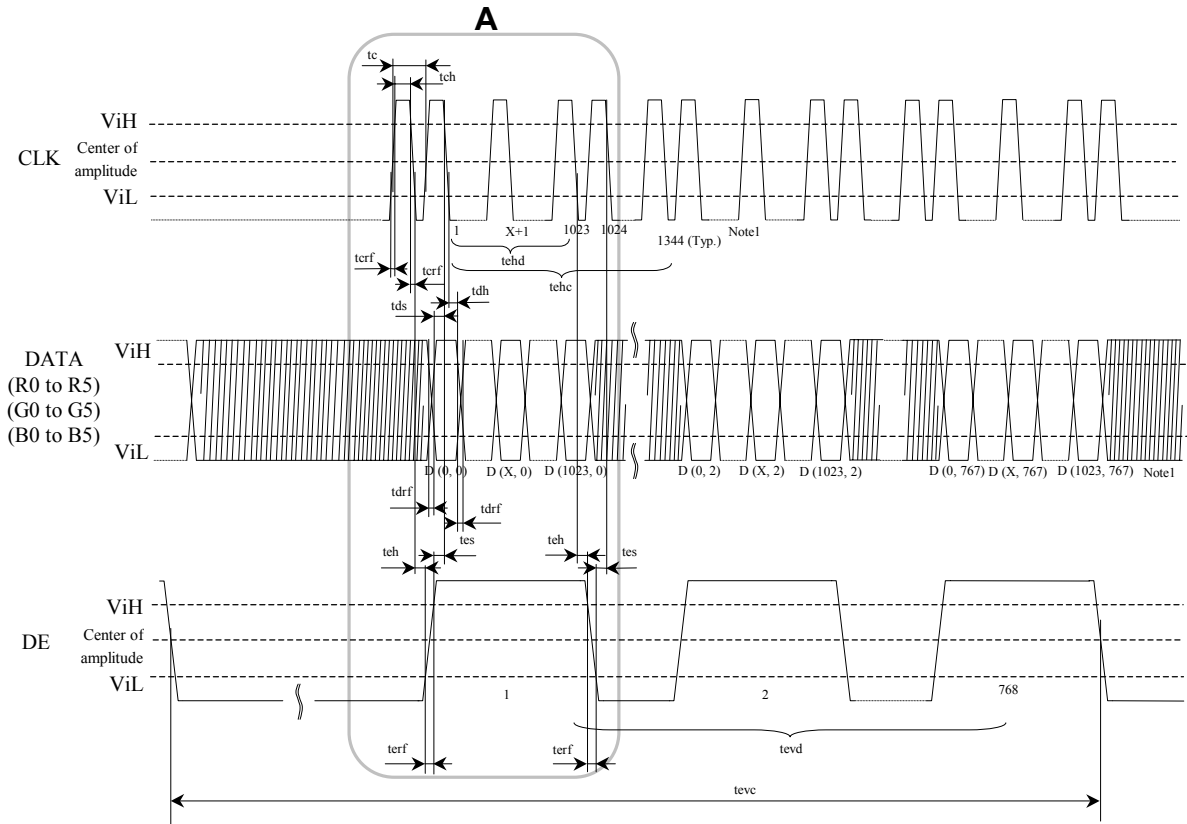

- Detail of A part

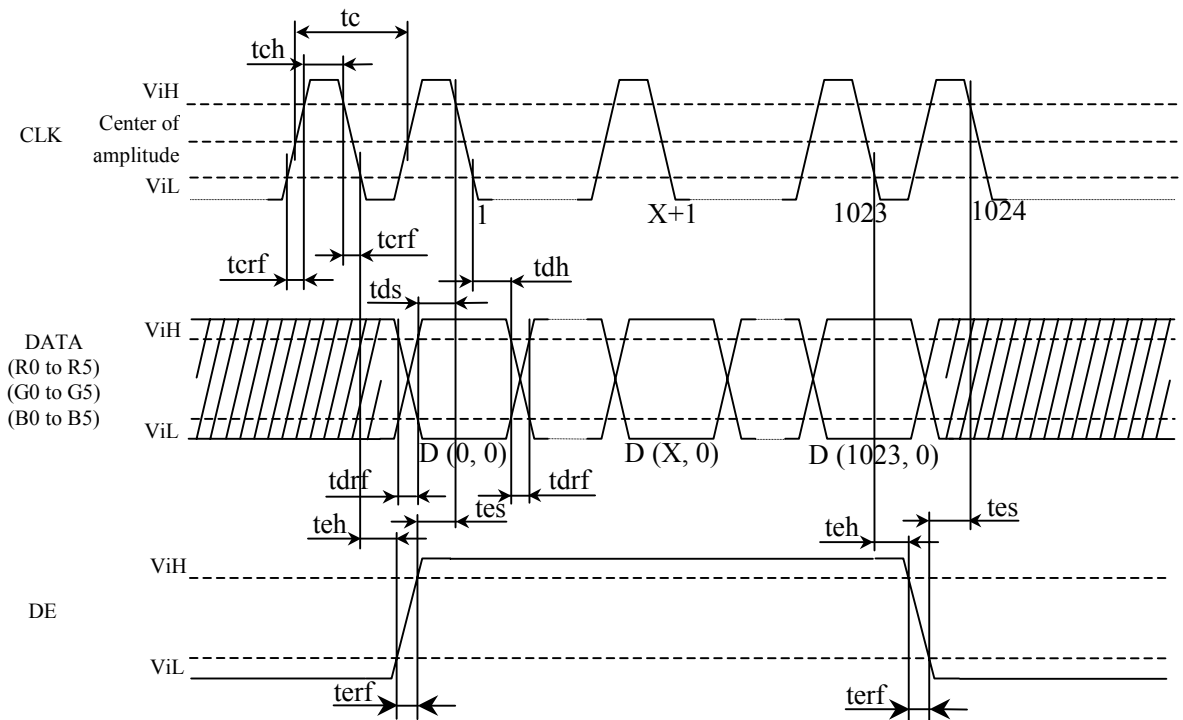

Note1: X is data number from 1 to 1023.

Note2: See the specifications of LVDS manufacturers for detailed design.

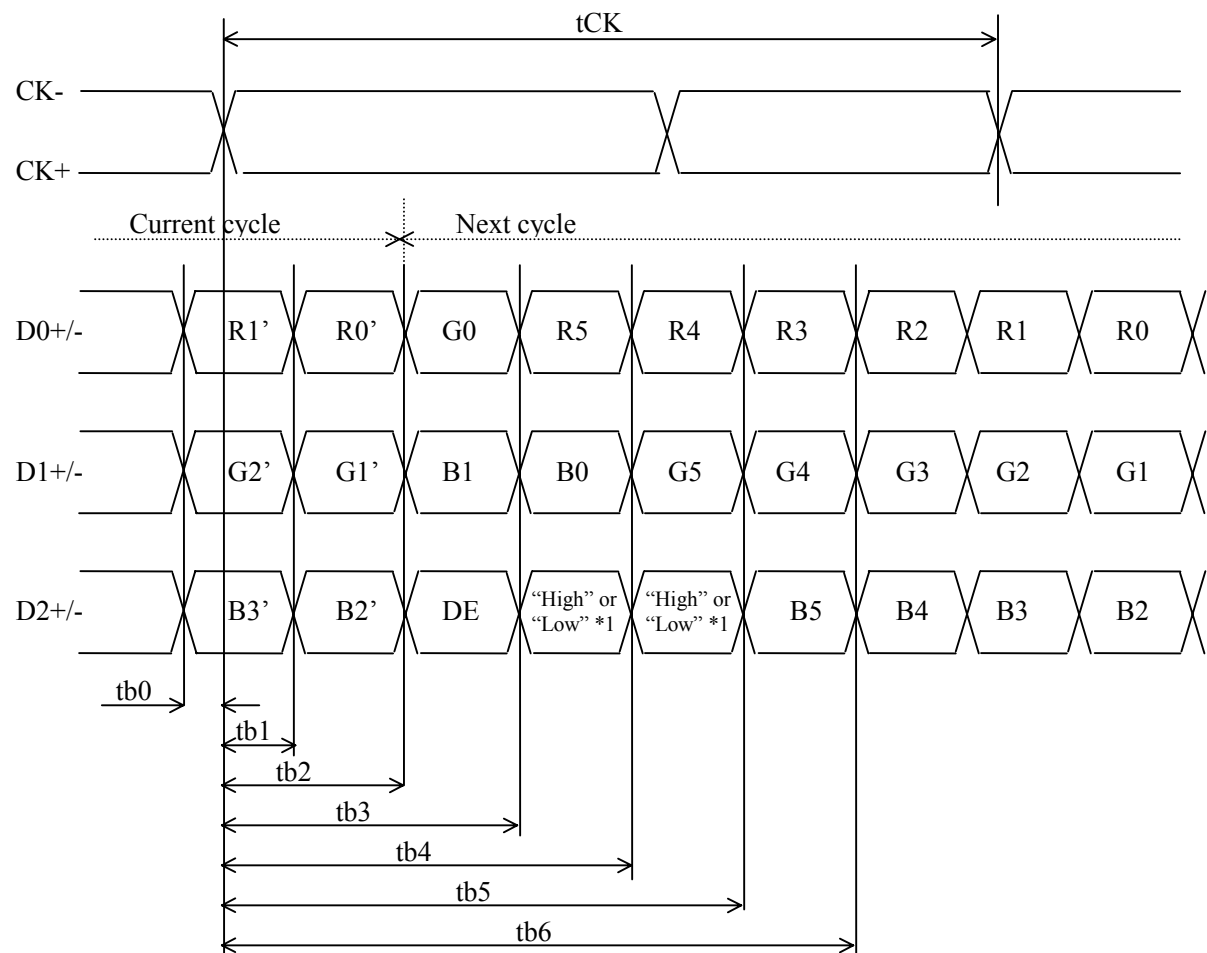

*1: These signals depends on input signals to TC4 and TC5 of LVDS transmitter. (See 4.7 How to connect with LVDS transmitter.)

4.11 OPTICAL CHARACTERISTICS

Parameter	Note1	Symbol	Condition	Min.	Typ.	Max.	Unit	Remarks
Contrast ratio		CR	White/Black at center, $\theta_{x\pm} = 0^\circ$, $\theta_{y\pm} = 0^\circ$	80	200	-	-	Note2
Luminance		L	White at center, $\theta_{x\pm} = 0^\circ$, $\theta_{y\pm} = 0^\circ$	240	330	-	cd/m ²	-
Luminance uniformity		LU	-	-	-	-	1.3	Note3

Reference data

Parameter	Note1	Symbol	Condition	Min.	Typ.	Max.	Unit	Remarks
Contrast ratio		CR	White/Black at center, $\theta_{x\pm} = 0^\circ$, $\theta_{y-} = 5^\circ$	-	450	-	-	Note2
Chromaticity		W	White (x, y)	-	0.29, 0.30	-	-	-
		R	Red (x, y)	-	0.63, 0.34	-	-	
		G	Green (x, y)	-	0.32, 0.55	-	-	
		B	Blue (x, y)	-	0.14, 0.09	-	-	
Color gamut		C	$\theta_{x\pm} = 0^\circ$, $\theta_{y\pm} = 0^\circ$ at center, to NTSC space	50	56	-	%	
Response time		Ton	White to Black	-	15	40	ms	Note4
		Toff	Black to White	-	40	80	ms	
Viewing angle	CR > 10	Right	θ_{x+}	$\theta_{y\pm} = 0^\circ$	50	65	-	Note5
		Left	θ_{x-}	$\theta_{y\pm} = 0^\circ$	50	65	-	
		Up	θ_{y+}	$\theta_{x\pm} = 0^\circ$	30	45	-	
		Down	θ_{y-}	$\theta_{x\pm} = 0^\circ$	35	50	-	

Note1: Measurement conditions are as follows.

$T_a = 25^\circ\text{C}$, $V_{CC} = 5\text{V}$, $V_{DDB} = 12.0\text{V}$

Optical characteristics are measured at luminance saturation after 20 minutes from working the product, in the dark room. Also measurement method for luminance is as follows.

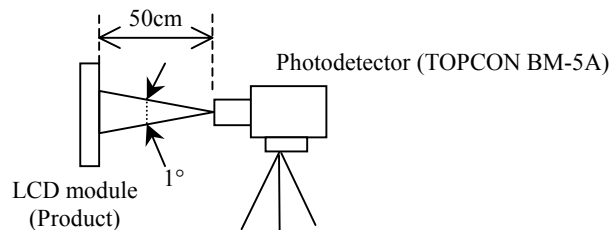

Note2: See '4.11.2 Definition of contrast ratio'.

Note3: See '4.11.3 Definition of luminance uniformity'.

Note4: See '4.11.4 Definition of response times'.

Note5: See '4.11.5 Definition of viewing angles'.

4.11.2 Definition of contrast ratio

The contrast ratio is calculated by using the following formula.

$$\text{Contrast ratio (CR)} = \frac{\text{Luminance of white screen}}{\text{Luminance of black screen}}$$

4.11.3 Definition of luminance uniformity

The luminance uniformity is calculated by using following formula.

$$\text{Luminance uniformity (LU)} = \frac{\text{Maximum luminance from ① to ⑤}}{\text{Minimum luminance from ① to ⑤}}$$

The luminance is measured at near the 5 points shown below.

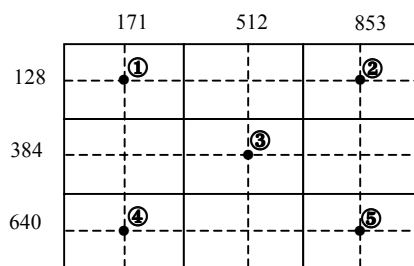

4.11.4 Definition of response times

Response time is measured, the luminance changes from "white" to "black", or "black" to "white" on the same screen point, by photo-detector. Ton is the time it takes the luminance change from 100% down to 10%. Also Toff is the time it takes the luminance change from 0% up to 90% (See the following diagram.).

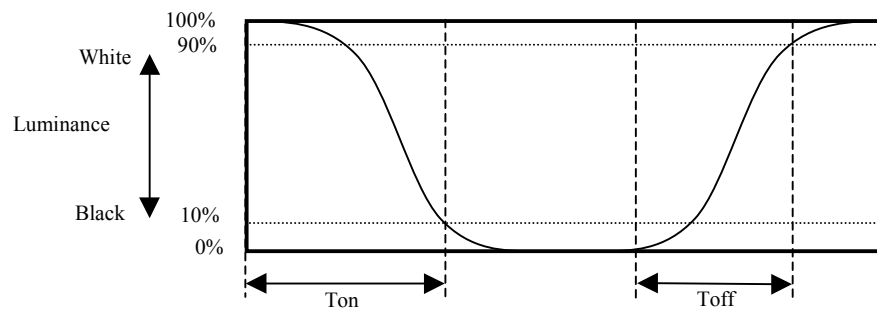

4.11.5 Definition of viewing angles

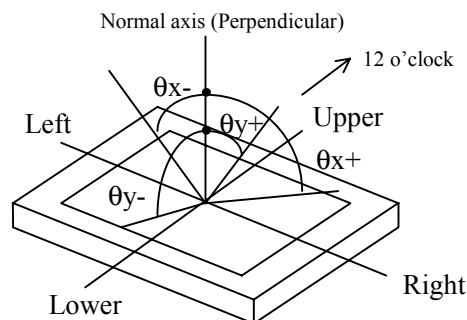

5. RELIABILITY TESTS

Test item	Test condition	Judgment
High temperature/humidity operation	50±2°C, RH=85% 240 hours, Display data is black.	Note1
Heat cycle (operation)	① 0°C ±3°C...1 hour 55°C ±3°C...1 hour ② 50 cycles , 4 hours/cycle ③ Display data is black.	Note1
Thermal shock (non-operation)	① -20°C ±3°C...30 minutes 60°C ±3°C...30 minutes ② 100 cycles ③ Temperature transition time is within 5 minutes.	Note1
Vibration (non-operation)	① 5-100Hz, 19.6m/s ² , 1 minute/cycle, X,Y,Z direction ② 50 times each direction	Note1, Note2
Mechanical shock (non-operation)	① 294m/s ² , 11ms X,Y,Z direction ② 3 times each direction	Note1, Note2
ESD (operation)	150pF, 150Ω, ±10kV 9 places on a panel *3 10 times each place at one-second intervals	Note1
Dust (operation)	15 kinds of dust (JIS-Z 8901) Hourly 15 seconds stir, 8 times repeat	Note1

Note1: No display malfunctions (Display functions are checked under the same conditions as out-going inspection.)

Note2: Physical damage

Note3: See the following figure for discharge points.

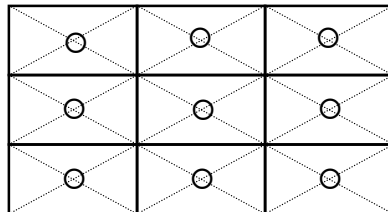

6. PRECAUTIONS

6.1 MEANING OF CAUTION SIGNS

The following caution signs have very important meaning. **Be sure to read '10.2 CAUTIONS', after understanding this contents!**



CAUTION

This sign has the meaning that customer will be injured by himself, or the product will sustain a damage, if customer has wrong operations.



This sign has the meaning that customer will get an electrical shock, if customer has wrong operations.



This sign has the meaning that customer will be injured by himself, if customer has wrong operations.

6.2 CAUTIONS



Do not touch HIGH VOLTAGE PART of the inverter while turned on! Danger of an electrical shock.



- * Pay attention to burn injury for the working backlight! It may be over 35°C from ambient temperature.
- * Do not shock and press the LCD panel and the backlight! Danger of breaking, because they are made of glass. (Shock: To be not greater 294m/s² and to be not greater 11ms, Pressure: To be not greater 19.6N)

6.3 ATTENTIONS

(1) Handling the product

- ① Take hold of both ends without touch the circuit board when customer pulls out products (LCD modules) from inner packing box. If customer touches it, products may be broken down or out of adjustment, because of stress to mounting parts.
- ② Do not hook cables nor pull connection cables such as flexible cable and so on, for fear of damage.
- ③ If customer puts down the product temporarily, the product puts on flat subsoil as a display side turns down.
- ④ Take the measures of electrostatic discharge such as earth band, ionic shower and so on, when customer deals with the product, because products may be damaged by electrostatic.
- ⑤ The torque for mounting screws must never exceed 0.392N·m. Higher torque values might result in distortion of the bezel.

- ⑥ Do not press or rub on the sensitive display surface. If customer clean on the panel surface, NEC Corporation recommends using the cloth with ethanolic liquid.
- ⑦ Do not push-pull the interface connectors while the product is working, because wrong power sequence may break down the product.

(2) Environment

- ① Dewdrop atmosphere must be avoided.
- ② Do not operate or store in high temperature or high humidity atmosphere. Keep the product in antistatic pouch in room temperature, because of avoidance for dusts and sunlight, if customer stores the product.
- ③ Do not operate in high magnetic field. Circuit boards may be broken down by it.
- ④ Use an original protection sheet on the product surface (polarizer). Adhesive type protection sheet should be avoided, because it may change color or properties of the polarizer.

(3) Specification for products

- ① Do not display the fixed pattern for a long time because it may cause image sticking. Use a screen saver, if the fixed pattern is displayed on the screen.
- ② The display color may be changed by viewing angle because of the use of condenser sheet in the backlight unit.
- ③ The luminance may be changed by voltage variation (voltage drop), even if power source applies recommended voltage to backlight inverter.
- ④ Optical characteristics may be changed by input signal timings.

(4) Other

- ① All GND, GNDB, VCC and VDDB terminals should be used without a non-connected line.
- ② Do not disassemble a product or adjust volume without permission of NEC Corporation.
- ③ See 'REPLACEMENT MANUAL FOR BACKLIGHT', if customer would like to replace backlight lamps.
- ④ Pay attention not to insert waste materials inside of products, if customer uses screwnails.
- ⑤ Pack the product with original shipping package, because of avoidance of some damages during transportation, when customer returns it to NEC Corporation for repair and so on.

General characteristics for the LCD

The following items are neither defects nor failures.

- * **Response time, luminance and color may be changed by ambient temperature.**
- * **The LCD may be seemed luminance non-uniformity, flicker, vertical seam or small spot by display patterns.**
- * **Optical characteristics (e.g. luminance, display uniformity, etc.) gradually is going to change depending on operating time, and especially low temperature, because the LCD has cold cathode fluorescent lamps.**

7.2 Rear view

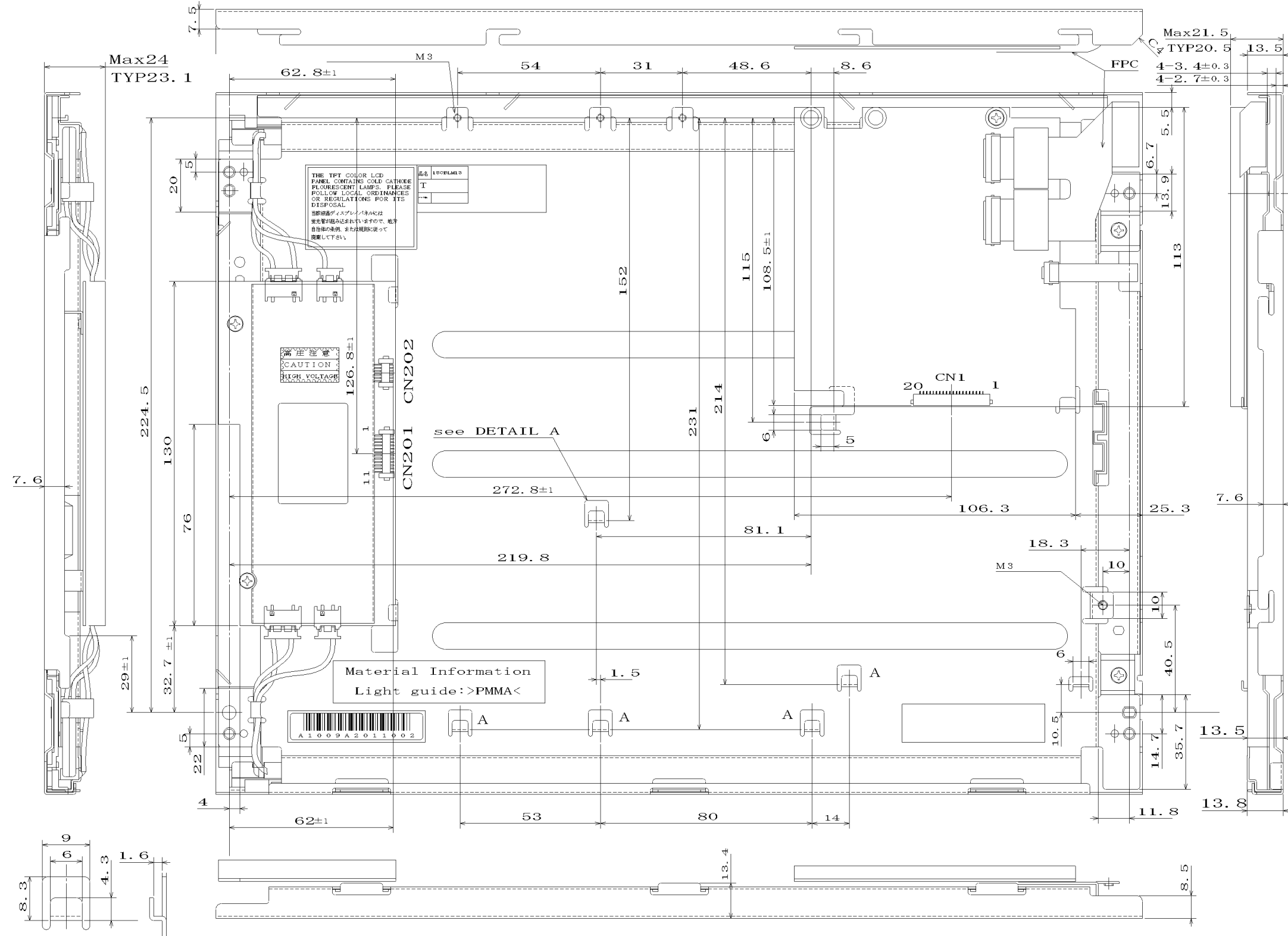

DETAIL A (S=2/1)

Note 1: Not shown tolerances of the dimensions are ±0.5mm.
 Note 2: The torque for mounting screw should never exceed 0.392N·m.

REVISION HISTORY

The inside of latest specifications is revised to the clerical error and the major improvement of previous edition. Only a changed part such as functions, characteristic value and so on that may affect a design of customers, are described especially below.

Edition	Document number	Prepared date	Revision contents and writer
1st edition	DOD - M - 0514	July 24, 2001	<p>Revision contents</p> <p>New issue</p> <p>Writer</p> <p>Approved by <u>Toshihide Ito</u></p> <p>Checked by _____</p> <p>Prepared by <u>R. Kawashima</u></p> <p>Toshihide Ito</p> <p style="text-align: right;">R.Kawashima</p>