

SIEMENS

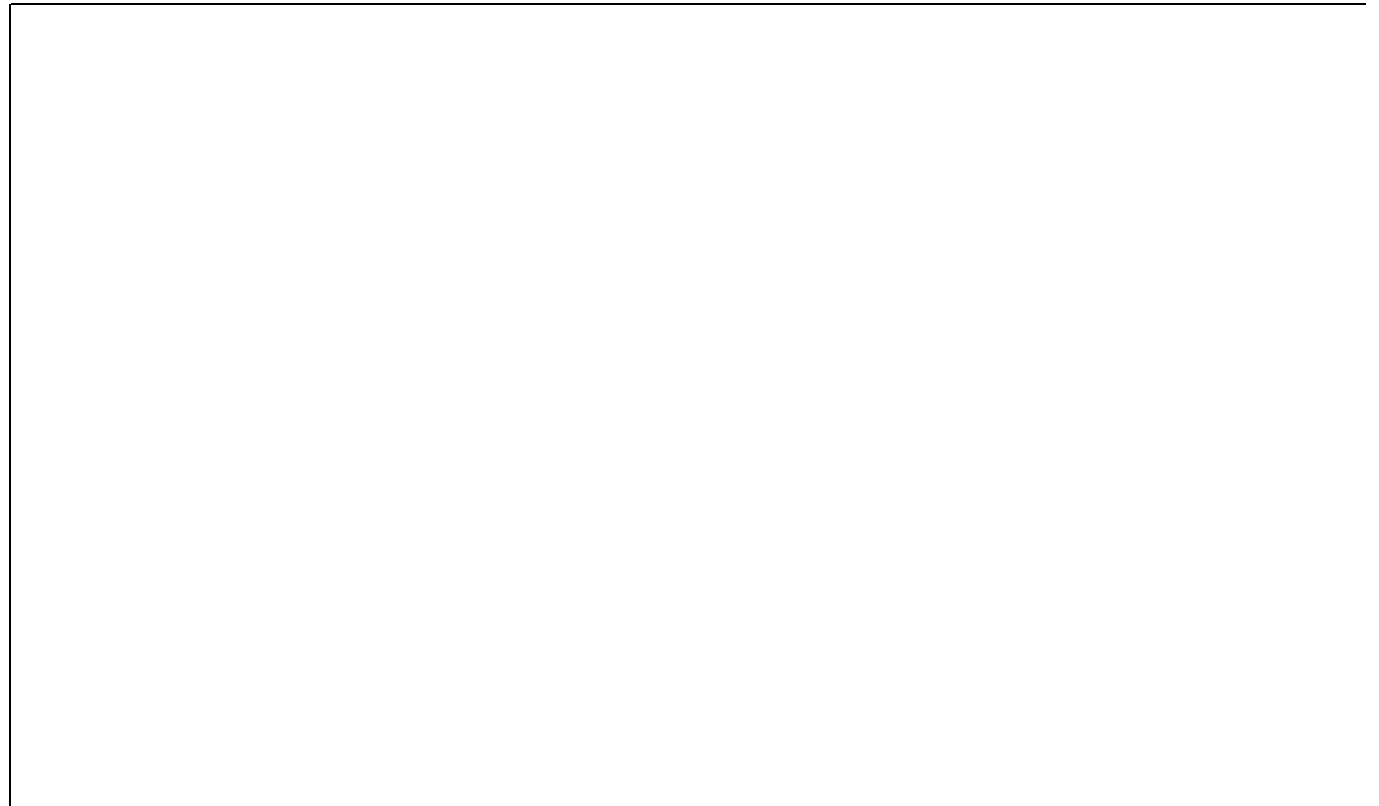

Components for Entertainment Electronics

2 Band TV Tuner

TUA 6012, TUA 6014

Mixer-Oscillator-PLL

Data Sheet 1998-09-01

Edition 1998-09-01

This edition was realized using the software system FrameMaker®

Published by Siemens AG, Bereich Halbleiter, Marketing-Kommunikation, Balanstraße 73, 81541 München

© Siemens AG 1998.
All Rights Reserved.

Attention please!

As far as patents or other rights of third parties are concerned, liability is only assumed for components, not for applications, processes and circuits implemented within components or assemblies.

The information describes the type of component and shall not be considered as assured characteristics.

Terms of delivery and rights to change design reserved.

For questions on technology, delivery and prices please contact the Semiconductor Group Offices in Germany or the Siemens Companies and Representatives worldwide (see address list).

Due to technical requirements components may contain dangerous substances. For information on the types in question please contact your nearest Siemens Office, Semiconductor Group.

Siemens AG is an approved CECC manufacturer.

Packing

Please use the recycling operators known to you. We can also help you – get in touch with your nearest sales office. By agreement we will take packing material back, if it is sorted. You must bear the costs of transport.

For packing material that is returned to us unsorted or which we are not obliged to accept, we shall have to invoice you for any costs incurred.

Components used in life-support devices or systems must be expressly authorized for such purpose!

Critical components¹ of the Semiconductor Group of Siemens AG, may only be used in life-support devices or systems² with the express written approval of the Semiconductor Group of Siemens AG.

- 1 A critical component is a component used in a life-support device or system whose failure can reasonably be expected to cause the failure of that life-support device or system, or to affect its safety or effectiveness of that device or system.
- 2 Life support devices or systems are intended (a) to be implanted in the human body, or (b) to support and/or maintain and sustain human life. If they fail, it is reasonable to assume that the health of the user may be endangered.

TUA 6012, TUA 6014		
Revision History:		Current Version: 1998-09-01
		Editorial Update
Previous Version:		04.98
Page (in previous Version)	Page (in current Version)	Subjects (major changes since last revision)
	5	Feature list updated
	6	Application description modified
	12	I ² C-Bus Interface description modified
	20	Max. value of parameter I_{POH} changed
	24	Test circuit modified
	30	Limit values for channel 6 beat and channel A-5 beat added

Data Classification

Maximum Ratings

Maximum ratings are absolute ratings; exceeding only one of these values may cause irreversible damage to the integrated circuit.

Recommended Operating Conditions

Under this conditions the functions given in the circuit description are fulfilled. Nominal conditions specify mean values expected over the production spread and are the proposed values for interface and application. If not stated otherwise, nominal values will apply at $T_A=25^{\circ}\text{C}$ and the nominal supply voltage.

Characteristics

The listed characteristics are ensured over the operating range of the integrated circuit.

Edition 1998-09-01

Published by Siemens AG, Semiconductor Group

Copyright © Siemens AG 1998. All rights reserved.

Terms of delivery and right to change design reserved.

Table of Contents		Page
1	Overview	5
1.1	Features	5
1.2	Functional Description	6
1.3	Application	6
1.4	Pin Configuration	7
1.5	Pin Definitions and Functions	8
1.6	Block Diagram	10
2	Circuit Description	11
2.1	Mixer-Oscillator Block	11
2.2	PLL Block	11
2.3	I ² C-Bus Interface	12
2.3.1	Bit Allocation Read/Write	13
2.3.2	Description of Symbols	14
2.3.3	UHF/VHF Bandswitch	14
2.3.4	Address Selection	15
2.3.5	Test Modes	15
2.3.6	Reference Divider Ratio	15
2.3.7	A/D Converter Levels	15
2.3.8	I ² C-Bus Timing Diagram	16
3	Electrical Characteristics	17
3.1	Absolute Maximum Ratings	17
3.2	Operating Range	18
3.3	AC/DC Characteristics	19
4	Test Circuit	24
4.1	DC and RF Parameter Measurement	24
4.2	Measurement of Crystal Oscillator Frequency	25
4.3	Equivalent I/O-Schematic	26
5	Application Circuits	27
5.1	Application Circuit 1, PAL (evaluation board)	27
5.2	Application Circuit 2, NTSC (Evaluation Board)	28
6	Electrical Diagrams	29
6.1	Input Admittance VHF Mixer Input $Y_0 = 20 \text{ ms}$ (symmetrical and single ended) ..	29
6.2	Input Impedance UHF Mixer Input $Z_0 = 50 \Omega$ (symmetrical)	30
6.3	Output Admittance IF Output $Y_0 = 20 \text{ ms}$ (symmetrical)	30
7	Package Outlines	31

2 Band TV Tuner Mixer-Oscillator-PLL

TUA 6012
TUA 6014

BIPOLAR

1 Overview

1.1 Features

General

- Suitable for NTSC and PAL tuners
- Full ESD protection

Mixer/Oscillator

- High impedance mixer input for VHF
- Low impedance mixer input for UHF
- 4 pin oscillator for VHF
- 4 pin oscillator for UHF

PLL

- PLL with short lock-in time;
no asynchronous divider stage
- High voltage VCO tuning output
- Fast I²C Bus
- 4 NPN bandswitch buffers
- Internal VHF/UHF switch
- Lock-in flag
- Power-down reset
- Programmable reference divider ratio (64, 80, 128)
- Programmable charge pump current

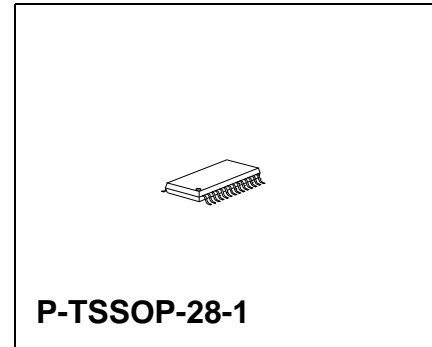

Type	Ordering Code	Package
TUA 6012XS	Q67006-A5234-A701	P-TSSOP-28-1
TUA 6014XS	Q67036-A1001-A701	P-TSSOP-28-1
TUA 6014-K	Q67036-A1006-A702	P-TSSOP-28-1
TUA 6014-S	Q67036-A1020-A701	P-TSSOP-28-1

1.2 Functional Description

The TUA6012, TUA6014 devices combine a digitally programmable phase locked loop (PLL), with a mixer-oscillator block including two balanced mixers and oscillators for use in TV tuners.

The PLL block with four hard-switched chip addresses forms a digitally programmable phase locked loop. With a 4 MHz quartz crystal, the PLL permits precise setting of the frequency of the tuner oscillator up to 900 MHz in increments of 50 kHz, 62.5 kHz or 31.25 kHz. The tuning process is controlled by a microprocessor via an I²C Bus. The device has four output ports, two of them (P0 and P1) can also be used as TTL input ports. A flag is set when the loop is locked. The input ports and lock flag can be read by the processor via the I²C Bus.

The mixer-oscillator block includes two balanced mixers (double balanced mixer with high-impedance input for VHF low, VHF high and low-impedance input for UHF), two frequency and amplitude-stable balanced oscillators for VHF low, VHF high and UHF, a low-noise reference voltage source and a band switch.

1.3 Application

The ICs are suitable for PAL and NTSC tuners in TV- and VCR-sets or cable set-top receivers for analog TV and Digital Video Broadcasting.

1.4 Pin Configuration

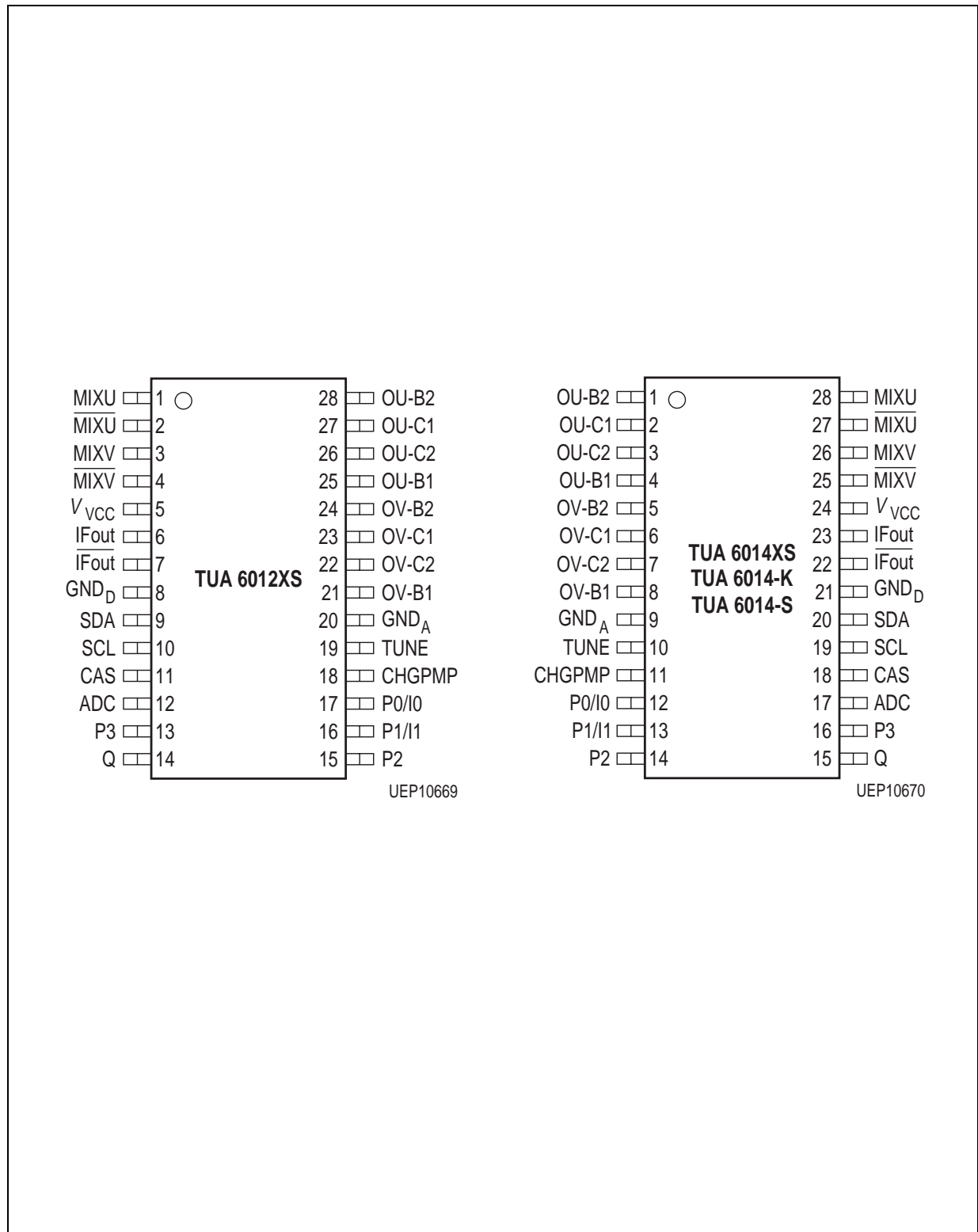

Figure 1

1.5 Pin Definitions and Functions

Pin No.		Symbol	Function
TUA 6014	TUA 6012		
1	28	OU-B2	UHF oscillator amplifier, high-impedance base input, symmetrical to OU-B1
2	27	OU-C1	UHF oscillator amplifier, high-impedance collector output, symmetrical to OU-C2
3	26	OU-C2	UHF oscillator amplifier, high-impedance collector output, symmetrical to OU-C1
4	25	OU-B1	UHF oscillator amplifier, high-impedance base input, symmetrical to OU-B2
5	24	OV-B2	VHF oscillator amplifier, high-impedance base input, symmetrical to OV-B1
6	23	OV-C1	VHF oscillator amplifier, high-impedance collector output, symmetrical to OV-C2
7	22	OV-C2	VHF oscillator amplifier, high-impedance collector output, symmetrical to OV-C1
8	21	OV-B1	VHF oscillator amplifier, high-impedance base input, symmetrical to OV-B2
9	20	GND _A	Analog Ground
10	19	TUNE	VCO tuning voltage output
11	18	CHGPMP	Charge pump output/loop filter
12	17	P0/I0	Port output/TTL input
13	16	P1/I1	Port output/TTL input
14	15	P2	Port output
15	14	Q	4 MHz low-impedance crystal oscillator input
16	13	P3	Port output
17	12	ADC	ADC input
18	11	CAS	Chip address select
19	10	SCL	Clock input for the I ² C Bus
20	9	SDA	Data input/output for the I ² C Bus
21	8	GND _D	Digital Ground

1.5 Pin Definitions and Functions (cont'd)

Pin No.		Symbol	Function
TUA 6014	TUA 6012		
22	7	$\overline{\text{IFout}}$	Inverse open collector mixer output, high-impedance, symmetrical to IFout
23	6	IFout	Open collector mixer output, high-impedance, symmetrical to $\overline{\text{IFout}}$
24	5	V_{VCC}	Positive supply voltage
25	4	$\overline{\text{MIXV}}$	VHF low or VHF high mixer input, high-impedance, symmetrical to MIXV
26	3	MIXV	VHF low or VHF high mixer input, high-impedance, symmetrical to $\overline{\text{MIXV}}$
27	2	$\overline{\text{MIXU}}$	UHF mixer input, low-impedance, symmetrical to MIXU
28	1	MIXU	UHF mixer input, low-impedance, symmetrical to $\overline{\text{MIXU}}$

1.6 Block Diagram

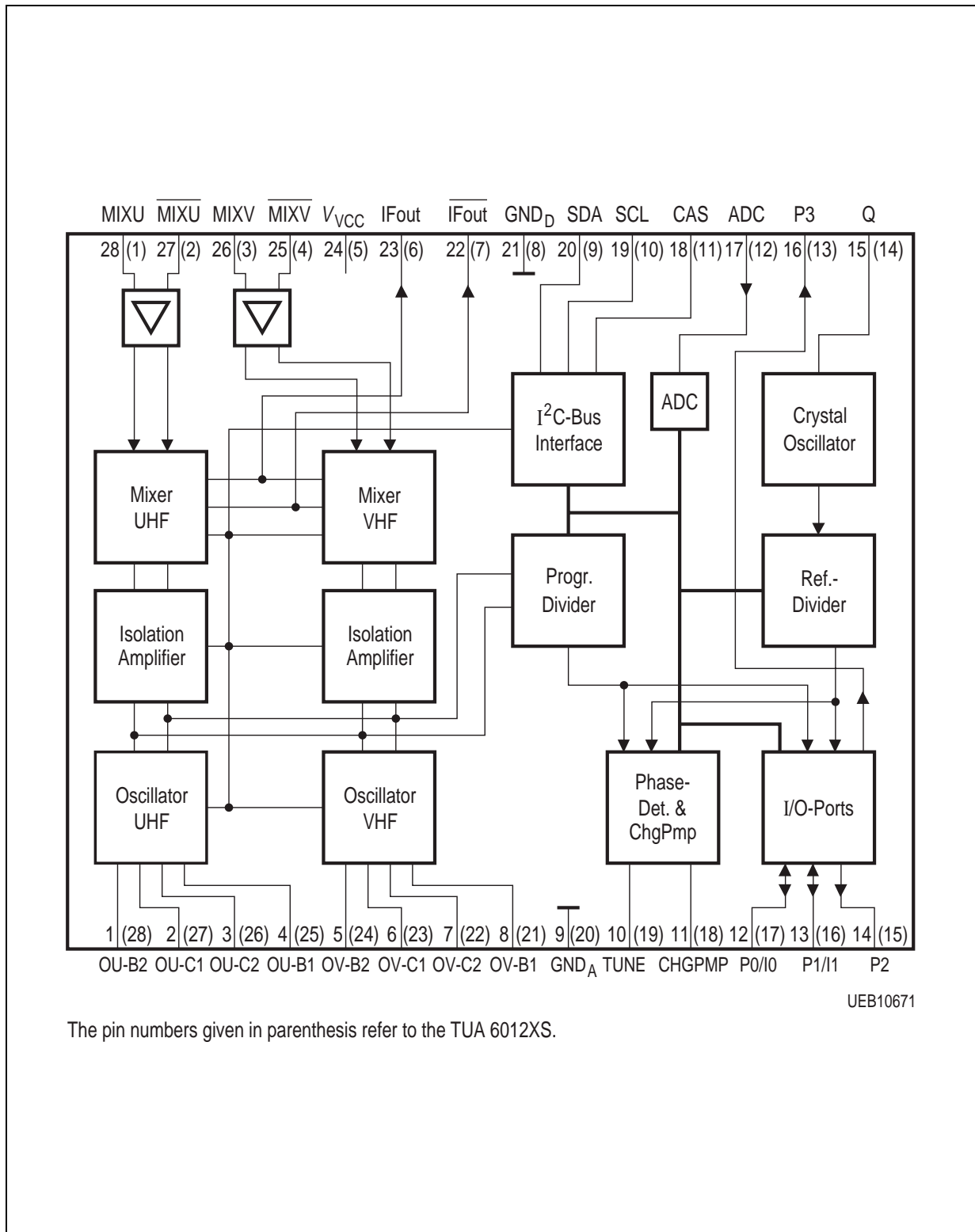

The pin numbers given in parenthesis refer to the TUA 6012XS.

Figure 2

2 Circuit Description

2.1 Mixer-Oscillator Block

The mixer oscillator section includes two balanced mixers (double balanced mixer), two balanced oscillators for VHF low and/or VHF high band and UHF, a reference voltage source and a band switch.

Filters between tuner input and IC separate the TV frequency signals into two bands. The band switching in the tuner front-end is done by using two, three or four port outputs. In the selected band the signal passes a tuner input stage with MOSFET amplifier, a double-tuned bandpass filter and is then fed to the balanced mixer input of the IC which has in case of VHF low/VHF high a high-impedance input and in case of UHF a low-impedance input. The VHF low/VHF high input can be used unsymmetrically by capacitively grounding one of the input pins. The input signal is mixed there with the signal from the activated on chip oscillator to the IF frequency and is available at the balanced high-impedance output pair ($I_{Fout}/\overline{IFout}$).

2.2 PLL Block

The mixer-oscillator signal VCO/\overline{VCO} is internally DC-coupled as a differential signal at the programmable divider inputs. The signal subsequently passes through a programmable divider with ratio $N = 256$ through 32767 and is then compared in a digital frequency/phase detector to a reference frequency $f_{ref} = 4 \text{ MHz}$ / reference divider ratio ($f_{ref} = 31.25 \text{ kHz}$, 50 kHz or 62.5 kHz). This frequency is derived from a unbalanced, low-impedance 4 MHz crystal oscillator (pin Q) divided by reference divider ratio (programmable reference divider ratio = 128, 80 or 64).

The phase detector has two outputs, UP and DOWN that drive two current sources $I+$ and $I-$ of a charge pump. If the negative edge of the divided VCO signal appears prior to the negative edge of the reference signal, the $I+$ current source pulses for the duration of the phase difference. In the reverse case the $I-$ current source pulses. If the two signals are in phase, the charge pump output (CHGPMP) goes into the high-impedance state (PLL is locked). An active low-pass filter integrates the current pulses to generate the tuning voltage for the VCO (internal amplifier, external pullup resistor at TUNE and external RC circuitry). The charge pump output is also switched into the high-impedance state when the control bit $T0 = 1$. Here it should be noted, however, that the tuning voltage can alter over a long period in the high-impedance state as a result of self-discharge in the peripheral circuitry. TUNE may be switched off by the control bit OS to allow external adjustments.

If the VCO is not working the PLL locks to a tuning voltage of 33 V.

By means of control bit 5I the pump current can be switched between two values by software. This programmability permits alteration of the control response of the PLL in the locked-in state. In this way different VCO gains can be compensated, for example.

The software-switched ports P0, P1, P2 and P3 are general-purpose open-collector outputs. The test bit T1 = 1, switches the test signals f_{ref} (4 MHz / reference divider ratio) and C_y (divided input signal) to P0 and P1 respectively. P0, P1 are bidirectional.

The lock detector resets the lock flag FL when the width of the charge pump current pulses is greater than the period of the crystal oscillator (i.e. 250 ns). Hence, when FL = 1, the maximum deviation of the input frequency from the programmed frequency is given by

$$\Delta f = \pm I_P (K_{VCO} / f_Q) (C_1 + C_2) / (C_1 C_2)$$

where I_P is the charge pump current, K_{VCO} the VCO gain, f_Q the crystal oscillator frequency and C_1, C_2 the capacitances in the loop filter (see "Application Circuits" on page 27). As the charge pump pulses at 62.5 kHz ($=f_{ref}$), it takes a maximum of 16 μ s for FL to be reset after the loop has lost lock state.

Once FL has been reset, it is set only if the charge pump pulse width is less than 250 ns for eight consecutive f_{ref} periods. Therefore it takes between 128 and 144 μ s for FL to be set after the loop regains lock.

2.3 I²C-Bus Interface

Data is exchanged between the processor and the PLL via the I²C Bus. The clock is generated by the processor (input SCL), while pin SDA functions as an input or output depending on the direction of the data (open collector, external pull-up resistor). Both inputs have hysteresis and a low-pass characteristic, which enhance the noise immunity of the I²C Bus.

The data from the processor pass through an I²C-Bus controller. Depending on their function the data are subsequently stored in registers. If the bus is free, both lines will be in the marking state (SDA, SCL are HIGH). Each telegram begins with the start condition and ends with the stop condition. Start condition: SDA goes LOW, while SCL remains HIGH. Stop condition: SDA goes HIGH while SCL remains HIGH. All further information transfer takes place during SCL = LOW, and the data is forwarded to the control logic on the positive clock edge.

The table "Bit Allocation" (see "Bit Allocation Read/Write" on page 13) should be referred to the following description. All telegrams are transmitted byte-by-byte, followed by a ninth clock pulse, during which the control logic returns the SDA line to LOW (acknowledge condition). The first byte is comprised of seven address bits. These are used by the processor to select the PLL from several peripheral components (chip select). The LSB bit (R/W) determines whether data are written into (R/W = 0) or read from (R/W = 1) the PLL.

In the data portion of the telegram during a WRITE operation, the MSB bit of the first or third data byte determines whether a divider ratio or control information is to follow. In

each case the second byte of the same data type has to follow the first byte. If the address byte indicates a READ operation, the PLL generates an acknowledge and then shifts out the status byte onto the SDA line. If the processor generates an acknowledge, a further status byte is output; otherwise the data line is released to allow the processor to generate a stop condition. The status word consists of two bits from the TTL input ports, three bits from the A/D converter, the lock flag and the power-on flag.

Four different chip addresses can be set by appropriate DC level at pin CAS (see "Address Selection" on page 15).

When the supply voltage is applied, a power-on reset circuit prevents the PLL from setting the SDA line to LOW, which would block the bus. The power-on reset flag POR is set at power-on and if V_{VCC} falls below 3.2 V. It will be reset at the end of a READ operation.

2.3.1 Bit Allocation Read/Write

Byte	MSB	Bit 6	Bit 5	Bit 4	Bit 3	Bit 2	Bit 1	LSB	Ack	Remarks
Write Data										
Address byte	1	1	0	0	0	MA1	MA0	0	A	
Progr. divider byte 1	0	n14	n13	n12	n11	n10	n9	n8	A	
Progr. divider byte 2	n7	n6	n5	n4	n3	n2	n1	n0	A	
Control byte 1	1	5I	T1	T0	1	RSA	RSB	OS	A	
Control byte 2	x	x	x	x	P3	P2	P1	P0	A	
Read Data										
Address byte	1	1	0	0	0	MA1	MA0	1	A	
Status byte	POR	FL	x	I1	I0	A2	A1	A0	A	

2.3.2 Description of Symbols

Symbol	Description
MA0, MA1	Address selection bits (see "Address Selection" on page 15)
n14 to n0	Programmable divider bits: $N = 2^{14} * n_{14} + 2^{13} * n_{13} + \dots + 2^3 * n_3 + 2^2 * n_2 + 2^1 * n_1 + n_0$
5I	Charge pump current: Bit = 0 : Charge pump current = 50 μ A Bit = 1 : Charge pump current = 220 μ A
T1, T0	Test bits (see "Test Modes" on page 15)
RSA, RSB	Reference divider bits (see "Reference Divider Ratio" on page 15)
OS	Tuning amplifier control bit: Bit = 0 : Enable V_{TUNE} Bit = 1 : Disable V_{TUNE}
PO, P1, P2, P3	NPN ports control bits Bit = 0 : NPN open-collector output is inactive, TTL inputs at P0, P1 Bit = 1 : NPN open-collector output is active UHF/VHF bandswitch (see "UHF/VHF Bandswitch" on page 14)
A0, A1, A2	ADC bits (see "A/D Converter Levels" on page 15)
I0, I1	Input data from P0/I0, P1/I1
FL	PLL lock flag Bit = 1 : Loop is locked
POR	Power-on reset flag Flag is set at power-on and reset at the end of READ operation
x	don't care

2.3.3 UHF/VHF Bandswitch

IC is in UHF Mode	Ports Pn			
	P0	P1	P2	P3
TUA 6012XS	x	1	x	x
TUA 6014XS	x	1	x	x
TUA 6014-K	x	x	1	x
TUA 6014-S	x	x	x	1

2.3.4 Address Selection

Voltage at CAS	MA1	MA0
$(0...0.1) * V_{VCC}$	0	0
Open circuit	0	1
$(0.4...0.6) * V_{VCC}$	1	0
$(0.9...1) * V_{VCC}$	1	1

2.3.5 Test Modes

Test Mode	T1	T0
Normal operation	0	0
Charge pump output, CHGPMP is in high-impedance state	0	1
P1 = C_y output, P0 = f_{ref} output	1	0
TTL-inputs I1/I0 are C_y / f_{ref} inputs of phase detector	1	1

2.3.6 Reference Divider Ratio

Reference Divider Ratio	RSA	RSB
80	x	0
128	0	1
64	1	1

2.3.7 A/D Converter Levels

Voltage at ADC	A2	A1	A0
$(0...0.15) * V_{VCC}$	0	0	0
$(0.15...0.3) * V_{VCC}$	0	0	1
$(0.3...0.45) * V_{VCC}$	0	1	0
$(0.45...0.6) * V_{VCC}$	0	1	1
$(0.6...1) * V_{VCC}$	1	0	0

2.3.8 I²C-Bus Timing Diagram

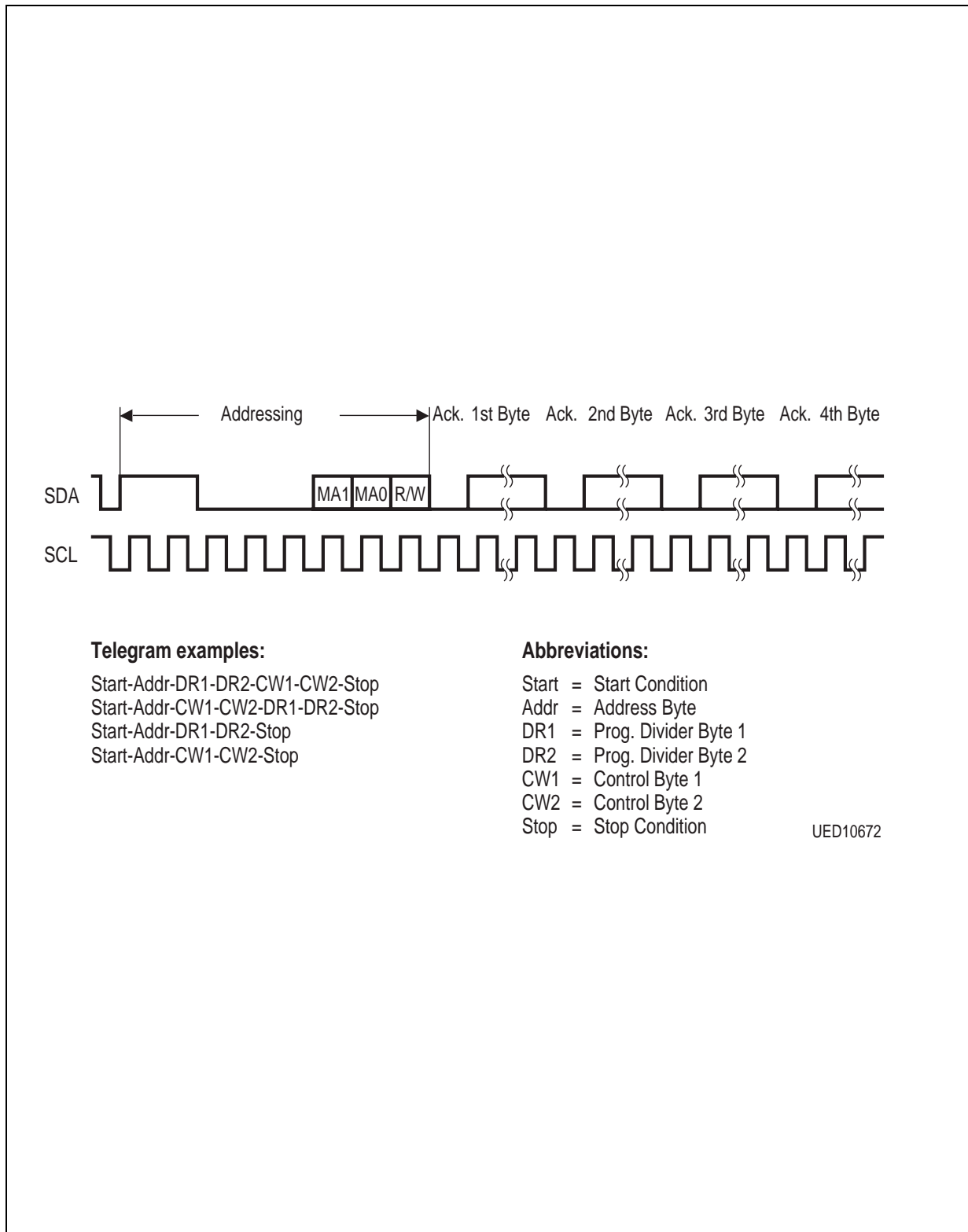

Figure 3

3 Electrical Characteristics

3.1 Absolute Maximum Ratings

Parameter ¹⁾	Symbol	Limit Values		Unit	Test Conditions
		min.	max.		
Supply voltage	V_{VCC}	- 0.3	5.5	V	
Junction temperature	T_J		125	°C	
Storage temperature	T_{Stg}	- 40	125	°C	
Thermal resistance (junction to ambient)	R_{thSA}		125	K/W	

PLL

CHGPMP	V_{CHGPMP}	- 0.3	3	V	
	I_{CHGPMP}		1	mA	
Crystal oscillator pins Q	V_Q		V_{VCC}	V	
	I_Q	- 5		mA	
Bus input/output SDA	V_{SDA}	- 0.3	V_{VCC}	V	
Bus output current SDA	$I_{SDA(L)}$		5	mA	Open collector
Bus input SCL	V_{SCL}	- 0.3	V_{VCC}	V	
Chip address switch CAS	V_{CAS}	- 0.3	V_{VCC}	V	
VCO tuning output (loop filter)	V_{TUNE}	- 0.3	35	V	
Port outputs P0...P3	V_P	- 0.3	V_{VCC}	V	
	$I_{P(L)}$	- 1	15	mA	$t_{max} = 0.1 \text{ s at } 5.5 \text{ V}$
Total port output current	$\Sigma I_{P(L)}$		20	mA	$t_{max} = 0.1 \text{ s at } 5.5 \text{ V}$

Mixer-Oscillator

Mix inputs VHF/HYPER	V_{MIXV}	- 0.3	3	V	
Mix inputs UHF	V_{MIXU}		2	V	
	I_{MIXU}	- 5	6	mA	
VCO base voltage	V_B	- 0.3	3	V	
VCO collector voltage	V_C		V_{VCC}	V	
IF output	V_{IFout}		6	V	
	$\overline{V_{IFout}}$		6	V	

3.1 Absolute Maximum Ratings (cont'd)

Parameter ¹⁾	Symbol	Limit Values		Unit	Test Conditions
		min.	max.		
ESD-Protection ²⁾					
All pins	V_{ESD}		1	kV	

¹⁾ All values are referred to ground (pin), unless stated otherwise.

Currents with a positive sign flows into the pin and currents with a negative sign flows out of pin.

²⁾ According to MIL STD 883D, method 3015.7 and EOS/ESD assn. standard S5.1 - 1993

Ambient Temperature under bias: $T_A = - 20 \text{ }^\circ\text{C}$ to +

Note: The maximal ratings may not be exceeded under any circumstances, not even momentary and individual, as permanent damage to the IC will result.

3.2 Operating Range

Parameter	Symbol	Limit Values		Unit	Test Conditions
		min.	max.		
Supply voltage	V_{VCC}	4.5	5.5	V	
Mixer output voltage	V_{IFout} $\overline{V_{IFout}}$	4.5	5.5	V	Open collector
Programmable divider factor	N	256	32767		
VHF mixer input frequency range	f_{MIXV}	40	500	MHz	
UHF mixer input frequency range	f_{MIXU}	350	900	MHz	
VHF oscillator frequency range	f_{OV}	75	560	MHz	
UHF oscillator frequency range	f_{OU}	380	950	MHz	
Ambient temperature	T_{amb}	- 20	85	$^\circ\text{C}$	

Note: Within the operational range the IC operates as described in the circuit description. The AC/DC characteristic limits are not guaranteed.

3.3 AC/DC Characteristics

Parameter	Symbol	Limit Values			Unit	Test Conditions
		min.	typ.	max.		
Digital Unit						
PLL						
Crystal Oscillator Connection Q						
Crystal frequency	f_Q	3.2	4.0	4.8	MHz	Series resonance
Crystal resistance	R_Q	10		100	Ω	Series resonance
Oscillation frequency	f_Q	3.99975	4.000	4.00025	MHz	$f_Q = 4$ MHz
Input impedance	Z_Q	- 500	- 700	- 900	Ω	$f_Q = 4$ MHz
Charge Pump Output CHGPMP						
HIGH output current	I_{CPH}	± 90	± 220	± 300	μA	$5I = 1, V_{CP} = 2$ V
LOW output current	I_{CPL}	± 22	± 50	± 75	μA	$5I = 0, V_{CP} = 2$ V
Tristate current	I_{CPZ}		1		nA	$T0 = 1, V_{CP} = 2$ V
Output voltage	V_{CP}	1.0		2.5	V	Locked
Drive Output TUNE (open collector)						
HIGH output current	I_{TH}			10	μA	$V_{TH} = 33$ V, OS = 1
LOW output voltage	V_{TL}			0.5	V	$I_{TL} = 1.0$ mA, T0 = 1
I²C-Bus						
Bus Inputs SCL, SDA						
HIGH input voltage	V_{IH}	3		5.5	V	
LOW input voltage	V_{IL}	0		1.5	V	
HIGH input current	I_{IH}			10	μA	$V_{IH} = V_S$
LOW input current	I_{IL}	- 10			μA	$V_{IL} = 0$ V
Bus Output SDA (open collector)						
HIGH output current	I_{OH}			10	μA	$V_{OH} = 5.5$ V
LOW output voltage	V_{OL}			0.4	V	$I_{OL} = 3$ mA
Edge Speed SCL, SDA						
Rise time	t_r			300	ns	
Fall time	t_f			300	ns	
Clock Timing SCL						
Frequency	f_{SCL}	0		400	kHz	

3.3 AC/DC Characteristics (cont'd)

Parameter	Symbol	Limit Values			Unit	Test Conditions
		min.	typ.	max.		
HIGH pulse width	t_H	0.6			μs	
LOW pulse width	t_L	1.3			μs	
Start Condition						
Set-up time	t_{susta}	0.6			μs	
Hold time	t_{hsta}	0.6			μs	
Stop Condition						
Setup time	t_{susto}	0.6			μs	
Bus free	t_{buf}	1.3			μs	
Data Transfer						
Setup time	t_{sudat}	0.1			μs	
Hold time	t_{hdat}	0			μs	
Input hysteresis SCL, SDA	V_{hys}		200		mV	
Pulse width of spikes which are suppressed	t_{sp}	0		50	ns	
Capacitive load for each bus line	C_L			400	pF	
Port Outputs P0, P1, P2, P3 (open collector)						
HIGH output current	I_{POH}			1	μA	$V_{\text{POH}} = 5 \text{ V}$
LOW output voltage	V_{POL}			0.5	V	$I_{\text{POL}} = 15 \text{ mA}$
TTL Port Inputs P0, P1						
HIGH input voltage	V_{PIH}	2.7			V	
LOW input voltage	V_{PIL}			0.8	V	
HIGH input current	I_{PIH}			10	μA	$V_{\text{PIH}} = 5.5 \text{ V}$
LOW input current	I_{PIL}	- 10			μA	$V_{\text{PIL}} = 0 \text{ V}$
ADC Port Input						
HIGH input current	I_{ADCH}			10	μA	
LOW input current	I_{ADCL}	- 10			μA	
Power on Reset						
POR = 1	V_{VCC}	2.6	3.2	3.6	V	

3.3 AC/DC Characteristics (cont'd)

Parameter	Symbol	Limit Values			Unit	Test Conditions
		min.	typ.	max.		
Address Selection Input CAS						
HIGH input current	$I_{CAS\ H}$			50	μA	$V_{CAS\ H} = 5\ \text{V}$
LOW input current	$I_{CAS\ L}$	- 50			μA	$V_{CAS\ L} = 0\ \text{V}$
Analog Unit						
Mixer-Oscillator						
Mixer current	$I_{IF-V/IF-U}$	4	6	8	mA	
Mixer output impedance	$R_{IFout}, R_{\overline{IFout}}$	13	20	27	$\text{k}\Omega$	Parallel equivalent circuit, $f_{IF} = 38.9\ \text{MHz}$ (see Figure 11)
	$C_{IFout}, C_{\overline{IFout}}$	0.35	0.5	0.7	pF	Parallel equivalent circuit, $f_{IF} = 38.9\ \text{MHz}$ (see Figure 11)
VHF Low and VHF High Band Section						
Current consumption	I_{VCC}	28	38	48	mA	
Mixer gain	G_{MIXV}	1	4	7	dB	$f_{RF} = 43.25$ to $463.25\ \text{MHz}$, $f_{IF} = 33.4$ to $58.75\ \text{MHz}$
Mixer noise figure	F_{MIXV}		5	8	dB	$f_{RF} = 43.25$ to $463.25\ \text{MHz}$
Mixer input impedance	R_{MIXV}	1	2	3	$\text{k}\Omega$	Parallel equivalent circuit, $f_{MIXV} = 300\ \text{MHz}$ (see Figure 9)
	C_{MIXV}		1	3	pF	Parallel equivalent circuit, $f_{MIXV} = 300\ \text{MHz}$ (see Figure 9)
Oscillator drift, PLL unlocked	Δf_{OscV}			400	kHz	$V_S = 5\ \text{V} \pm 10\%$
	Δf_{OscV}			500	kHz	$\Delta T = 25\ \text{°C}$
	Δf_{OscV}			100	kHz	$t = 5\ \text{s}$ up to $15\ \text{min}$ after switching on

3.3 AC/DC Characteristics (cont'd)

Parameter	Symbol	Limit Values			Unit	Test Conditions
		min.	typ.	max.		
Oscillator pulling, PLL unlocked	V_{MIXV}	100	108		$\text{dB}\mu\text{V}$	$\Delta f = 10 \text{ kHz}$ $f_{RF} = 48.25 \text{ MHz}$
	V_{MIXV}	100	108		$\text{dB}\mu\text{V}$	$\Delta f = 10 \text{ kHz}$ $f_{RF} = 399.25 \text{ MHz}$
N + 5 pulling, PLL unlocked	V_{MIXV}	- 50			dBc	$f_{RF} = 48.25 \text{ MHz},$ $f_{RF1} = 48.25 \text{ MHz},$ $P_{RF} = P_{RF1} =$ 80 $\text{dB}\mu\text{V}$
	V_{MIXV}	- 50			dBc	$f_{RF} = 399.25 \text{ MHz},$ $f_{RF1} = 437.25 \text{ MHz},$ $P_{RF} = P_{RF1} =$ 80 $\text{dB}\mu\text{V}$
Oscillator phase noise	$L(f_M)_{VHF}$	- 80	- 86		$\text{dBc}/$ Hz	$f_M = 10 \text{ kHz},$ application circuit 1

UHF Section

Current consumption	I_{VCC}	30	41	52	mA	
Mixer gain	G_{MIXU}	11	14	17	dB	$f_{RF} = 367.25 \text{ to}$ $863.25 \text{ MHz}, f_{IF} =$ 33.4 to 58.75 MHz
Mixer noise figure	F_{MIXU}		6	9	dB	$f_{RF} = 367.25 \text{ to}$ 615.25 MHz
	F_{MIXU}		7	10	dB	$f_{RF} = 623.25 \text{ to}$ 863.25 MHz
Mixer input impedance	R_{MIXU}	14	20	26	Ω	Serial equivalent circuit, $f_{MIXU} = 600 \text{ MHz}$ (see Figure 10)
	L_{MIXU}	3	6	9	nH	Serial equivalent circuit, $f_{MIXU} = 600 \text{ MHz}$ (see Figure 10)

3.3 AC/DC Characteristics (cont'd)

Parameter	Symbol	Limit Values			Unit	Test Conditions
		min.	typ.	max.		
Oscillator drift, PLL unlocked	Δf_{OscU}			400	kHz	$V_S = 5 V \pm 10\%$
	Δf_{OscU}			800	kHz	$\Delta T = 25 \text{ }^\circ\text{C}$
	Δf_{OscU}			100	kHz	$t = 5 \text{ s up to 15 min after switching on}$
Oscillator pulling, PLL unlocked	V_{MIXU}	100	108		dB μ V	$\Delta f = 10 \text{ kHz}$ $f_{RF} = 375.25 \text{ MHz}$
	V_{MIXU}	100	108		dB μ V	$\Delta f = 10 \text{ kHz}$ $f_{RF} = 847.25 \text{ MHz}$
N + 5 pulling, PLL unlocked	V_{MIXU}	- 50			dBc	$f_{RF} = 471.25 \text{ MHz},$ $f_{RF1} = 510.25 \text{ MHz},$ $P_{RF} = P_{RF1} =$ 80 dB μ V
	V_{MIXU}	- 50			dBc	$f_{RF} = 847.25 \text{ MHz},$ $f_{RF1} = 886.25 \text{ MHz},$ $P_{RF} = P_{RF1} =$ 80 dB μ V
Oscillator phase noise	$L(f_M)_{UHF}$	- 80	- 86		dBc/ Hz	$f_M = 10 \text{ kHz},$ application circuit 1

Rejection at the IF Output

Channel 6 beat	INT_{CH6}	60	66		dBc	$V_{RFpix} = V_{RFsnd} =$ 80 dB μ V ¹⁾
Channel A-5 beat	INT_{CHA-5}	63	69		dBc	$V_{RFpix} = 80 \text{ dB}\mu\text{V}$ ²⁾

¹⁾ Channel 6 beat is the interfering product of $f_{RFpix}, f_{RFsnd} - f_{OSC}$ of channel 6 at 42 MHz.

²⁾ Channel A-5 beat is the interfering product of $f_{RFpix} + f_{RFsnd} - f_{OSC}$ of channel A-5, $f_{BEAT} = 45.5 \text{ MHz}$.
The possible mechanisms are: $f_{OSC} - 2 * f_{IF}$ or $2 * f_{RFpix} - f_{OSC}$. For the measurement $V_{RF} = 80 \text{ dB}\mu\text{V}$.

Supply Voltage $V_{VCC} = 5 \text{ V}$
Ambient Temperature $T_{amb} = 25 \text{ }^\circ\text{C}$

4 Test Circuit

4.1 DC and RF Parameter Measurement

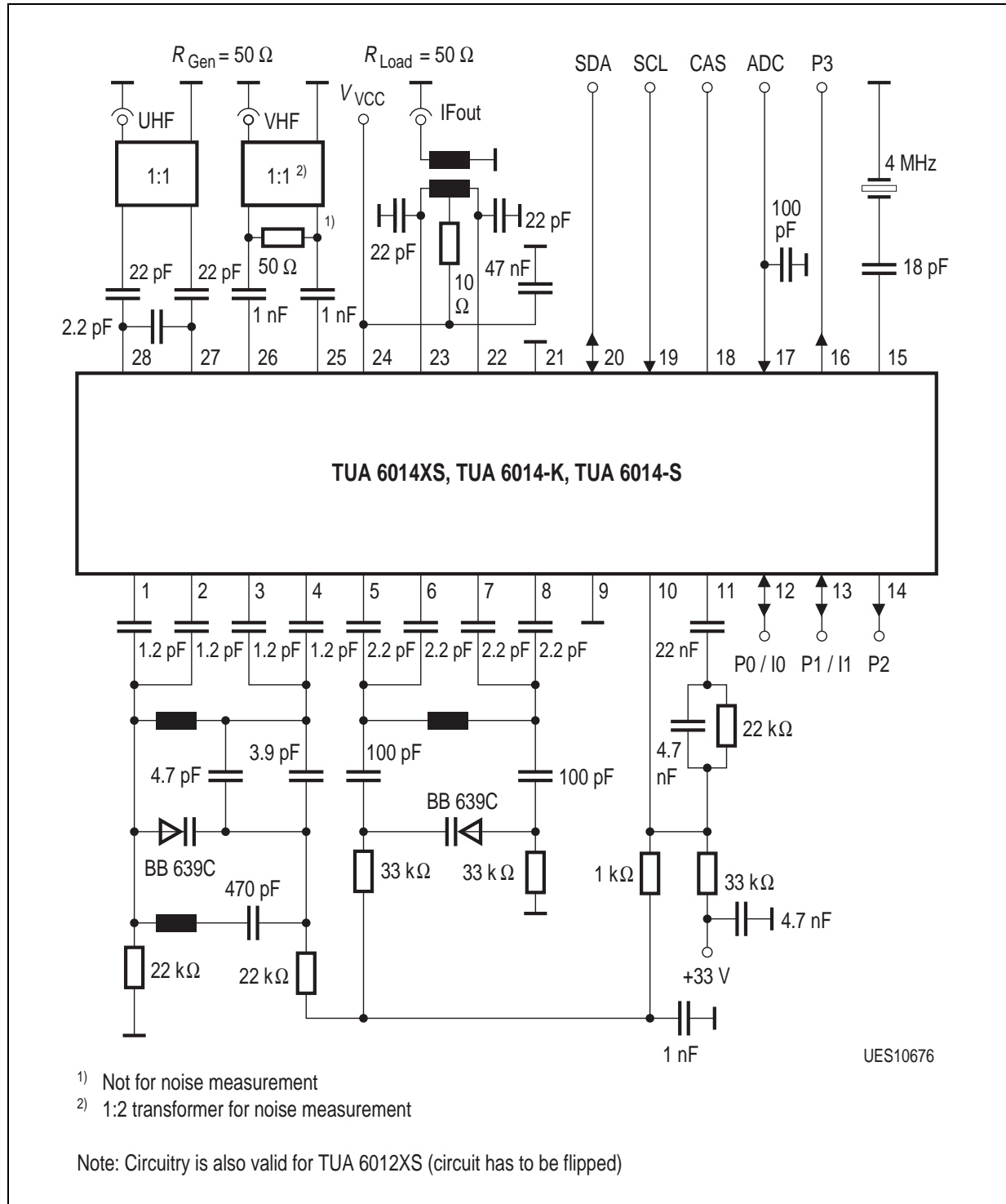

Figure 4

4.2 Measurement of Crystal Oscillator Frequency

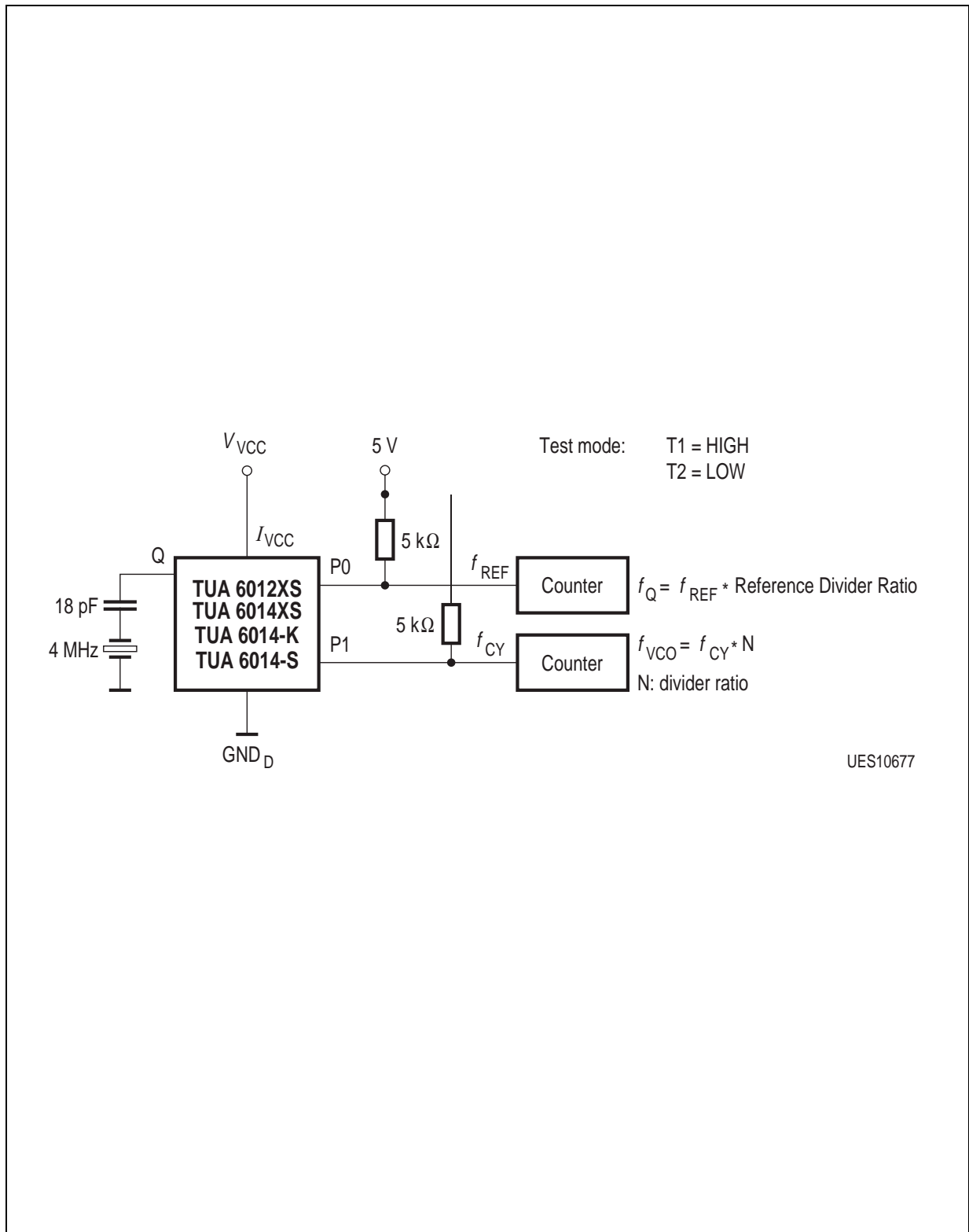

Figure 5

4.3 Equivalent I/O-Schematic

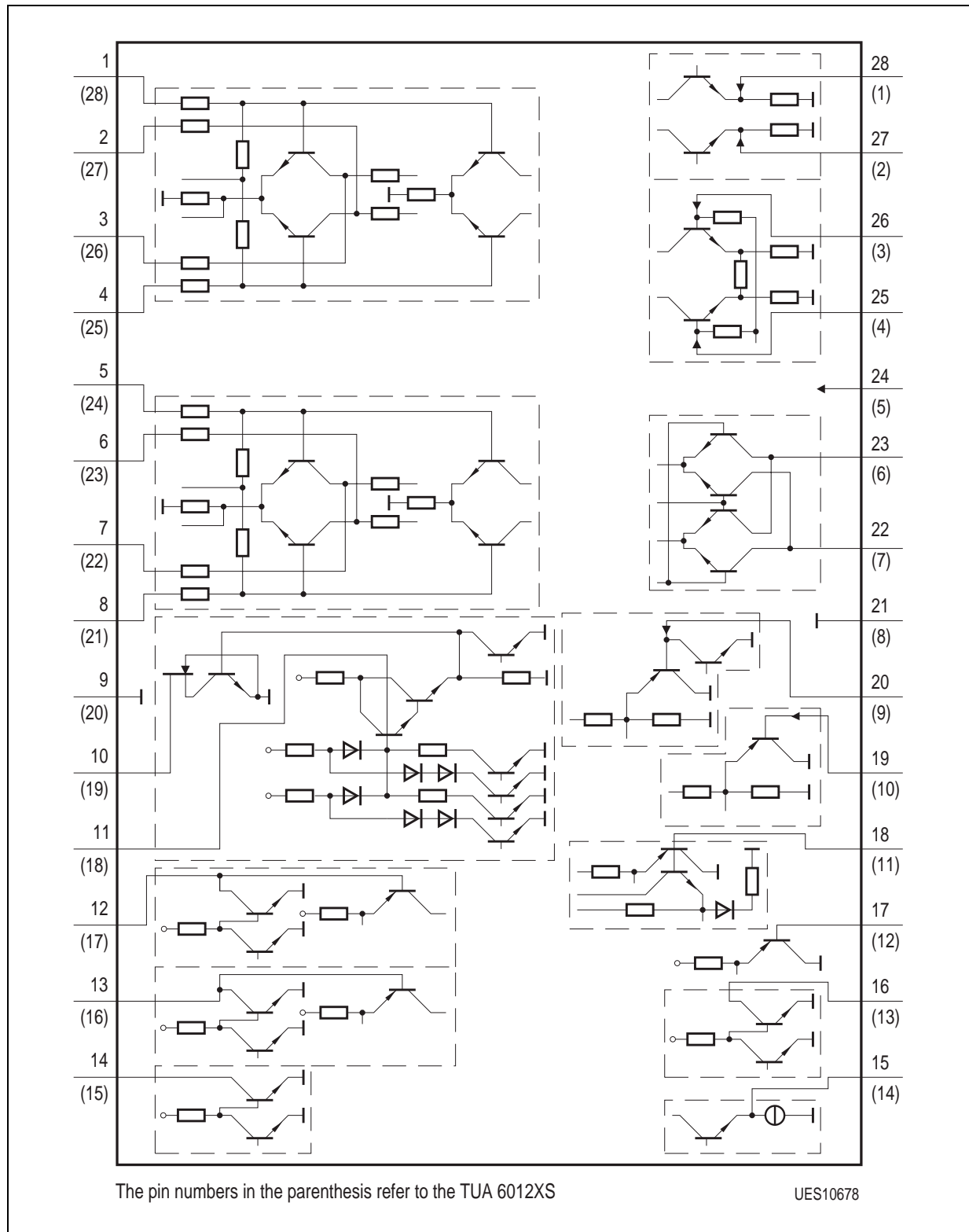

Figure 6

5 Application Circuits

5.1 Application Circuit 1, PAL (evaluation board)

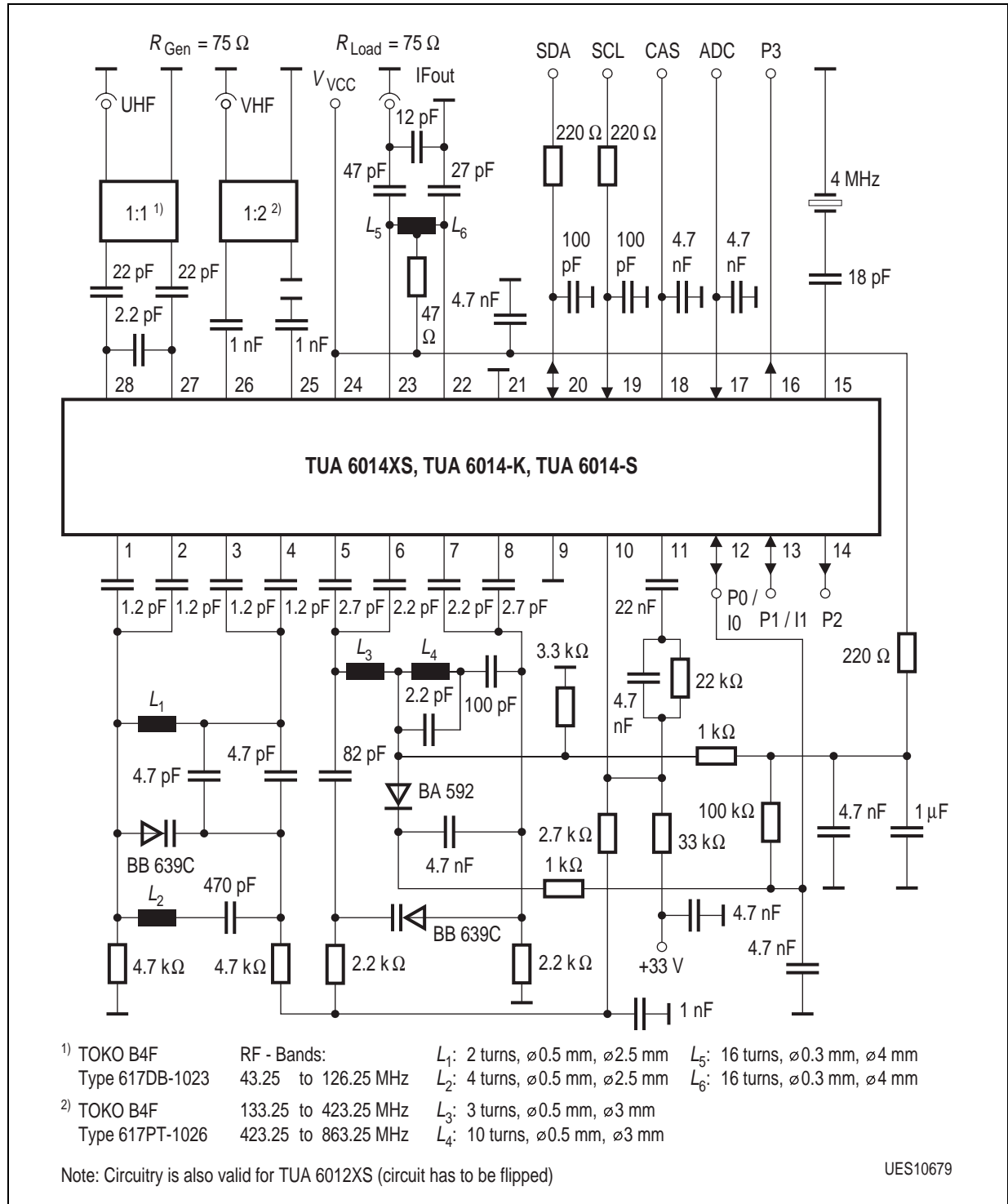

Figure 7

5.2 Application Circuit 2, NTSC (Evaluation Board)

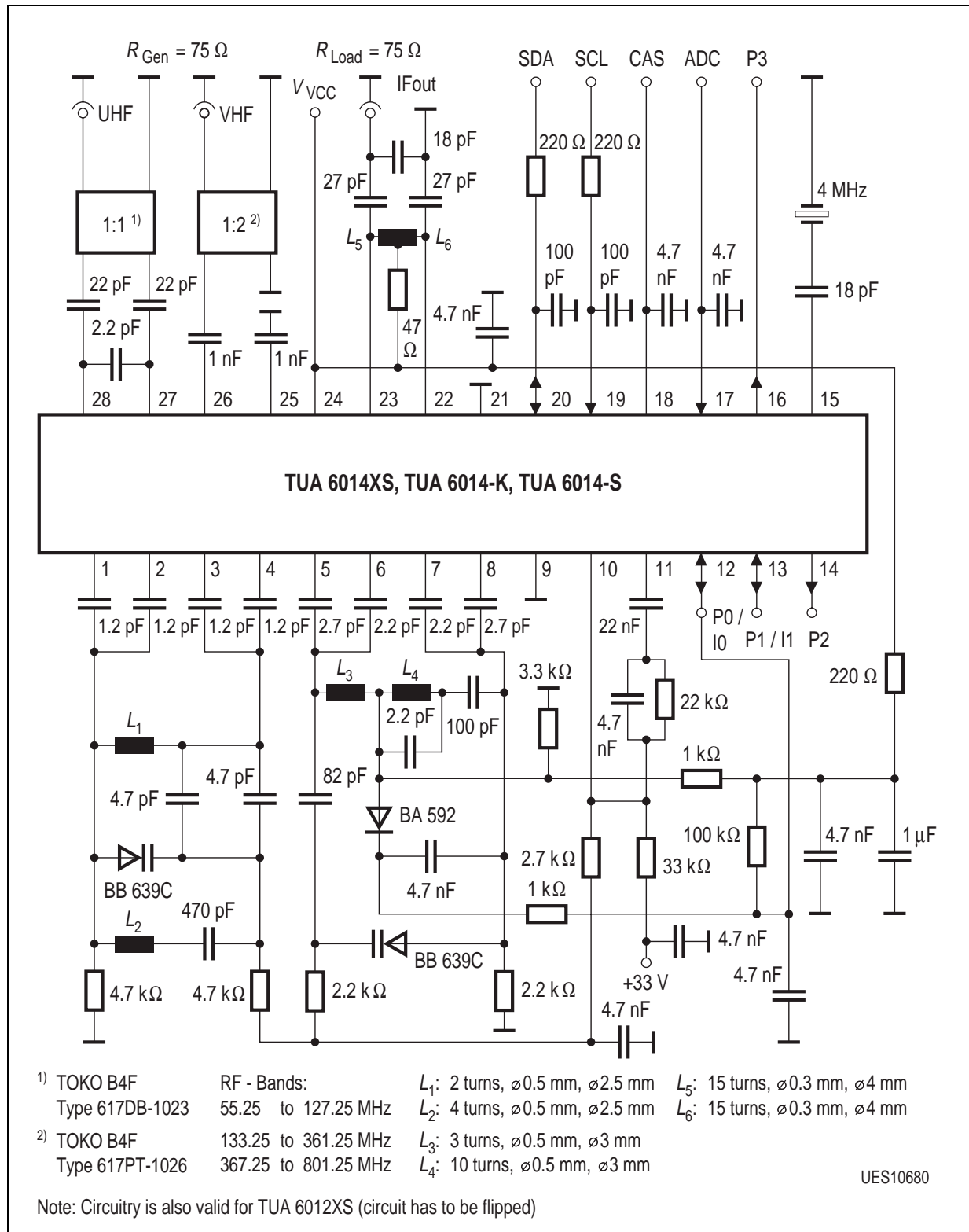

Figure 8

6 Electrical Diagrams

6.1 Input Admittance VHF Mixer Input $Y_0 = 20 \text{ ms}$
(symmetrical and single ended)

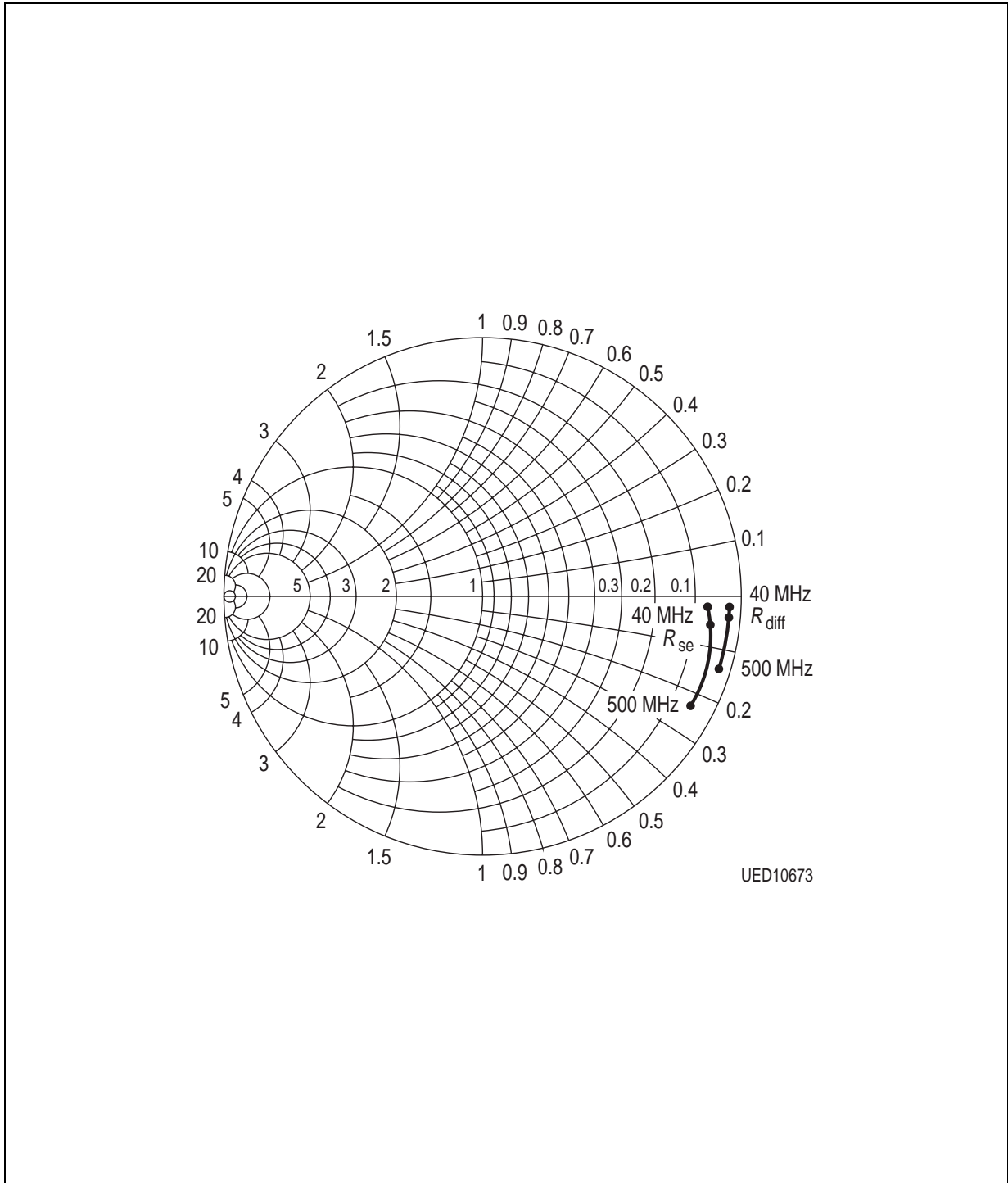

Figure 9

6.2 Input Impedance UHF Mixer Input $Z_0 = 50 \Omega$ (symmetrical)

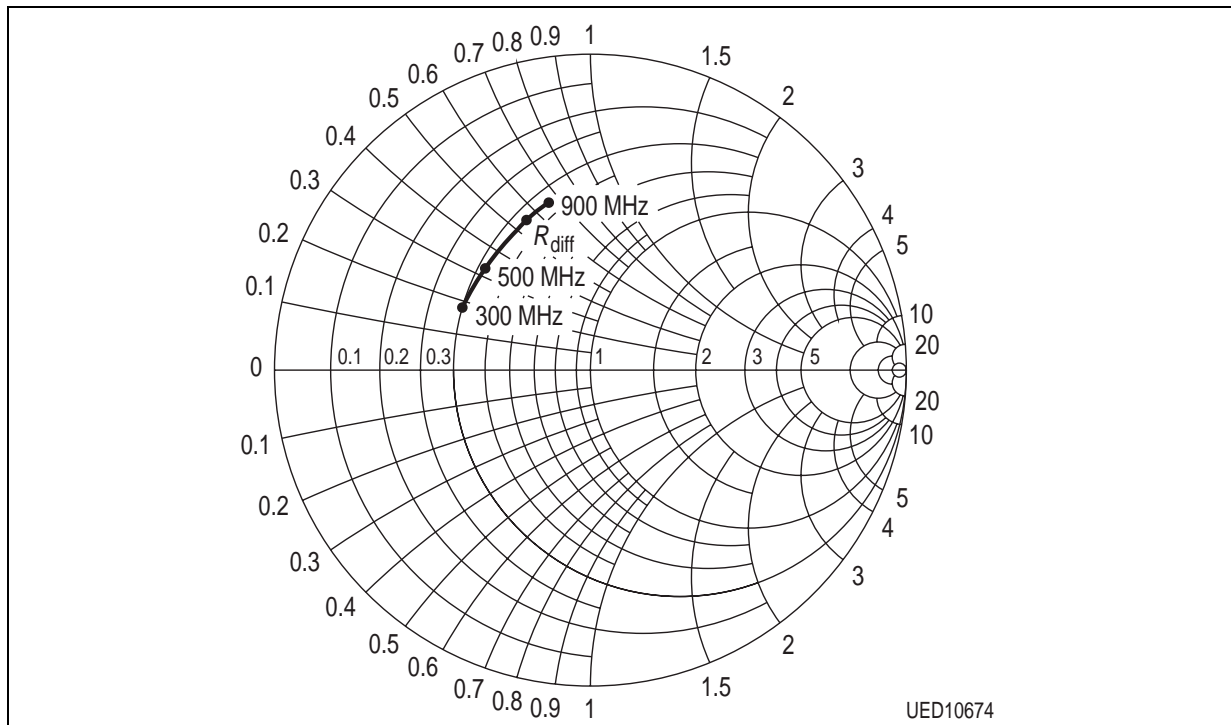

Figure 10

6.3 Output Admittance IF Output $Y_0 = 20 \text{ ms}$ (symmetrical)

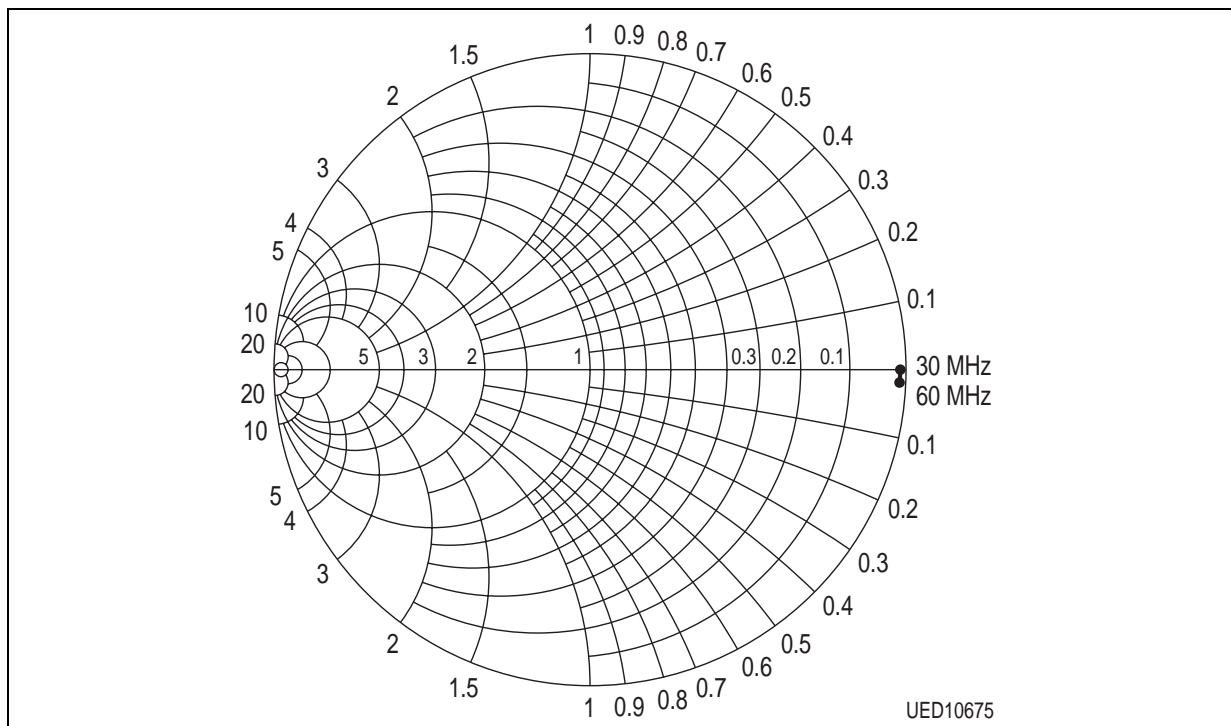

Figure 11

7 Package Outlines

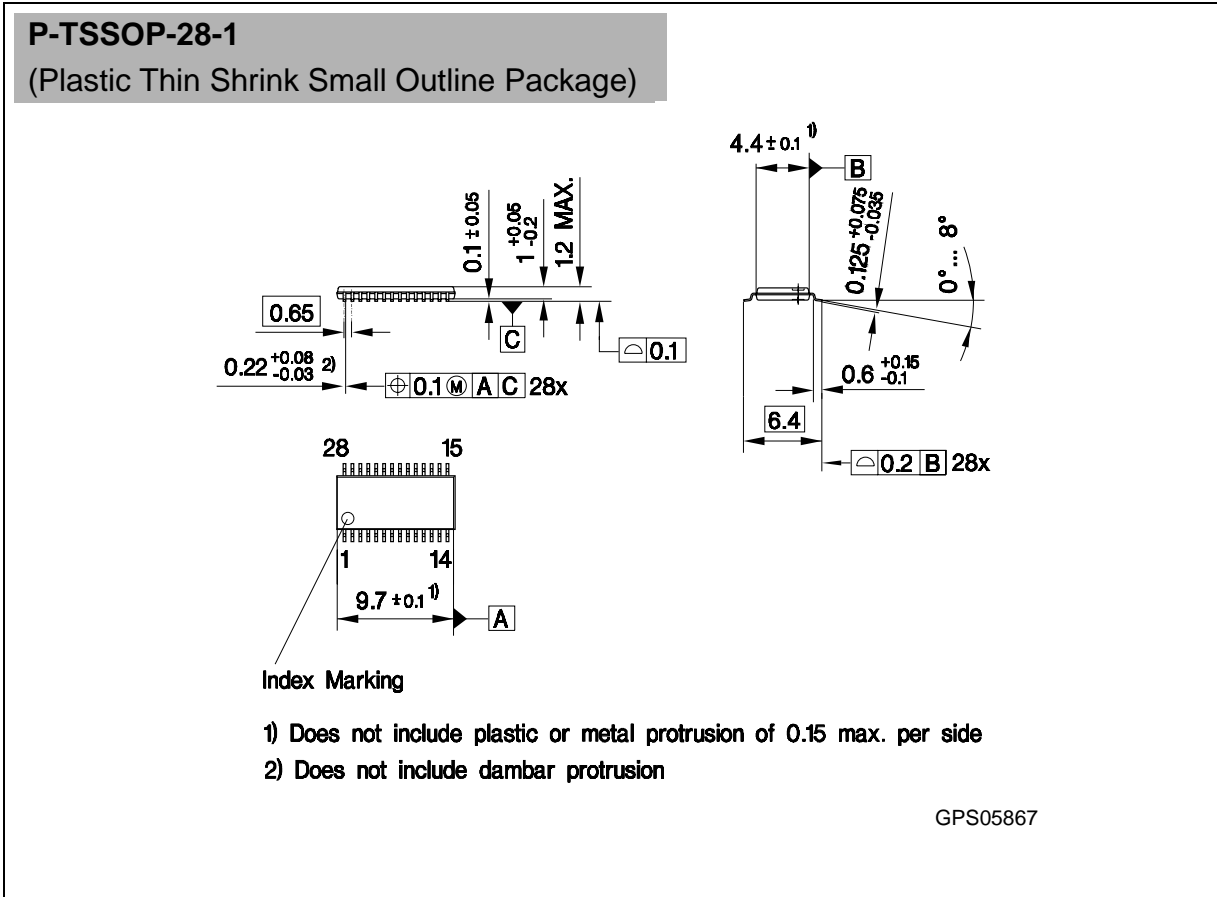

Figure 12