

MOTOROLA

Automotive Selector Guide

Quarter 2, 2001

motorola.com/semiconductors/automotive/

Product information for:

Automotive SMARTMOS™

Automotive Sensors

Automotive Microcontrollers:

8-Bit 68HC05, 68HC08, and 68HC11

16-Bit 68HC12 and 68HC16

32-Bit 683XX, PowerPC™, and M•CORE™

LIN Technology for Automotive

 **Digital DNA™**
from Motorola

WHAT'S NEW!

Section	Description
SMARTMOS	Revision of the SMARTMOS device tables
Sensors	Addition of MPXAZ4100 and MPXAZ4115 Automotive Media Resistant Pressure Sensors
68HC12 Family	Upgrade of PC68HC12BC32 device to XC qualification status Removal of XC68HC812A4 and XC68HC912BD32 devices; not recommended for new design-ins
68HC05 Family	MC68HC05J1A, XC68HC705JJ7, MC68HC05JJ6, XC68HC705JP7, MC68HC05JP6, XC68HC805K3, MC68HC05K3, MC68HC705KJ1, XC68HC705V8, XC68HC05V7, XC68HC705V12, and MC68HC05V12 devices not recommended for new designs
68HC11 Family	Removal of MC68HC811E2 device, not recommended for new designs
System Example Diagrams	Revision of all system diagrams
Nomenclature	Addition of PowerPC device numbering system
Package Options	Addition of PBGA and Super Small Outline packaging

For Q2, the Sensor Products Division is proud to announce the introduction of our new Media Resistant Automotive Pressure Sensors. The MPXAZ4100A and MPXAZ4115A use our new media resistant package. These devices can be used in automotive applications where the sensor may be in contact with destructive liquids or aggressive gases. Our popular integrated on-chip circuitry in a media resistant package is a winning combination!

- Visit www.pemicro.com/ics08 for FREE windows-based development software, including simulators, assemblers, and debuggers for Motorola's M68HC08 Family of microcontrollers.
- Visit www.mcu.motsps.com to view Motorola's offering in technical support, including development tools, documentation, new searchable FAQs, and freeware.
- Visit motorola.com/semiconductors/automotive/ldrivers/index.html for the latest information on Motorola Low-Level Drivers for Powertrain applications.
- Visit mot-sps.com/products/microcontrollers/software for information on Motorola OSEK products, including documentation, order information, and product support.

MOTOROLA SMARTMOS SOLUTIONS

SMARTMOS Motorola's SMARTMOS allows designers to interface high-precision components with the harsh automotive environment.

Cost-Effective Ideally suited for rugged automotive applications, SMARTMOS solutions offer a cost-effective blend of analog, digital, and robust power silicon that enables integrated, mixed-signal, power control ICs.

Functionality SMARTMOS solutions implement traditional analog functions with smaller die size, and a modular process produces components with the minimum number of process steps for each circuit, minimizing overhead.

Benefits Motorola's SMARTMOS technology brings a wide range of benefits to today's designs, including component reductions, power flexibility, durability, efficiency, precision, high-performance analog, and robustness.

Occupant Safety SMARTMOS squib drivers, power supplies, communications interfaces, and other devices for occupant safety systems are in vehicles around the globe.

For additional information, please visit:

Documentation
mcu.motps.com/documentation/index.html
 (mask set errata, specifications, application notes, and other literature)

Automotive Home Page
motorola.com/semiconductors/automotive/

Multiplex Transceivers — LIN, ISO9141, J1850 Physical Interfaces

Motorola Device Number	Device Description	Main Characteristics	Package	Bus Type and Standard	Protection	Supply	I Standby Max	Other Features	Control and Status Reporting	MC Status
MC33199	ISO9141 serial link driver	K&L lines (at 200kbps)	SO14	ISO9141, K and L lines	I lim, thermal	5V & 12V battery	—	Baud rate up to 200kbps	—	Now
MC33290	ISO9141 serial link interface	K line only — OBD II compatible	SO8/8P	ISO9141 K line	I lim, thermal	5V & 12V battery	50µA	Sleep mode	//	Now
MC33390	J1850 serial transceiver	J1850 low-speed multiplexing bus	SO8	J1850	I lim	—	—	—	—	Now
MC33399	LIN: local interconnect network physical interface	LIN: local interconnect network physical interface	SO8	LIN single wire	I lim, thermal	12V battery	50µA	Wake up input pin, control of external voltage regulator	//	4Q01

Multiplex Transceivers — CAN Physical interface Components

Motorola Device Number	Device Description	Main Characteristics	Package	Bus Type and Standard	Protection	Supply	I Standby Max	Other Features	Control and Status Reporting	MC Status
MC33388	CAN low-speed fault tolerant physical interface	CAN low-speed fault tolerant physical interface	SO14	CAN low-speed, dual wires	Fault tolerant	5V & 12V battery	25µA	Wake up input pin, fault tolerant physical interface	//	Now
MC33389	System base chip	Dual Vreg+LS CAN+WDOG+3 wk up inputs	HSOP20/SO28	CAN low-speed, dual wires	Fault tolerant	12V battery	150µA	Dual voltage regulator, watchdog, wake up input, sleep mode, cyclic sense	SPI 2MHz	2Q01

Multiplex Transceivers — Distributed Systems Interface Components

Motorola Device Number	Device Description	Main Characteristics	Package	System Type	No. of Channels	Current Limit	Max Voltage	Communications	MC Status
MC33790	DSIP — 2-channel DSI physical interface for bus masters	Dual current-limited waveshaped outputs, current sensing inputs, 3.3 V and 5 V	SOW16	DIST	2	150mA	26.5	SPI	Now

* denotes the Max Amp rating is dependant on PCB and hex
 OT = over temp protection

OL = open load protection
 // = parallel communication

SPI = serial peripheral interface

SMARTMOS

Power ICS — Low-Side Switches

Motorola Device Number	Device Description	Main Characteristics	Package	No. of Channels	High/Low	Ron (mΩ)	I LIM.	I Standby Max	Protection	Control	Status Reporting	MC Status
MC33385	Quad low side driver	4 times 2A, at Tamb = 125°C	HSOP20, SO28	4	L	500	3A	—	S/C, I, T	//	SPI	Now
MC33397	SCOWL — selectively configurable outputs for worldwide loads	User configurable to be: 6 x 900mΩ outputs OR 2 x 300mΩ outputs at TJ = 25°C (1.5W & 500mΩ at TJ = 150°C)	SOW24 QFN32 (7x7)	2 or 6	L	2X300, 6X900	1.5A	10μA	S/C, I, T	SPI	SPI	1Q01
MC33298	OSS — octal serial switch w/SPI	8 times 1000mA, at Tamb = 125°C	SOW24	8	L	650	3–6A	50μA	S/C, I, T	SPI	SPI	Now
MC33291	BOSS — basic octal serial switch w/SPI	8 times 500mA, at Tamb = 125°C	SOW24	8	L	1000	1–3A	25μA	S/C, I, T	SPI	SPI	Now
MC33880	COSS — configurable octal serial switch w/SPI	8 output hardware configurable high-side/low-side switch with 8-bit serial input control	SOW28 QFN32 (7x7)	8	H/L	1400	1.2A	25μA	S/C, I, T	SPI	SPI w/2 PWM	4Q01

Power ICS — High Side Switches

MC33143	Dual high-side switch	2 times 1A, at Tamb = 125°C	SOW24	2	H	380	3–6A	300μA	S/C, I, T	//	2 status pins	Now
MC33286	Gemini — dual high-side switch	2 times 3.5A*	SOW20	2	H	2x35	30A	5μA	S/C, I, T	//	1 St/Chnl (OT / OL)	Now
MC33288	Flasher — dual high-side switch with current sense	2 times 8A*	HSOP20	2	H	2x25	30A	5μA	S/C, I, CR, T	//	1 St/Dev (OT / OL)	Now
MC33289	DHSS — dual high-side switch for inductive loads	2 times 3A*	SOW20	2	H	2x40	9A	5μA	S/C, I, T	//	1 St/Chnl (OT / OL)	Now
MC33486	DHSB — dual high-side for H-bridge	2 times 10A*	HSOP20	2	H	15	35A	5μA	S/C, I, CM, T	//		Now
MC33487	Flasher lite — dual 20mΩ high-side driver with current sense	2 times 4.5A*	SOW20	2	H	2x25	40A	5μA	S/C, I, CR, T	//	1 St/Chnl (OT / OL)	2Q01
MC33880	COSS — configurable octal serial switch w/SPI	8 output hardware configurable high-side/low-side switch with 8-bit serial input control	SOW28 QFN32 (7x7)	8	H/L	1400	1.2A	25μA	S/C, I, T	SPI	SPI w/2 PWM	4Q01

Power ICS — H-Bridges and Configurable Switches

MC33186	150mΩ H-bridge	40V/150mΩ per FET	HSOP20	4	H/L	150	6A	20mA	S/C, I, T	//	1 status pin (OC, OT)	Now
MC33192	Mi-bus interface stepper motor con.		16SO	—	—	—	—	—	—	—	—	Now
MC33886	ETHIC — H-bridge	(225mΩ@150°C)	HSOP20 QFN44 (9x9)	4	H/L	120	6A	20mA	S/C, I, T	//	1 status pin (OC, OT)	2Q01
MC33887	FIESTA — H-bridge with sleep mode and current sense	(130mΩ@25°C)	SO28 QFN44 (9x9)	4	H/L	130	6A	25μA	S/C, I, T	//	1 status pin (OC, OT)	4Q01
MC33486	DHSB — dual high-side for H-bridge, protects and controls 2 external low-side FETs	10A*	HSOP20	2	H	2x15	35A	5μA	S/C, I, CR, T	//	1 status pin (OC, OT)	2Q01
MC33253	Full bridge pre-driver with AOP for body electronic application	Full bridge pre-driver, 1A pulse current, cross conduction suppression, global enable, OAP, body electronic application	SO28	4	H/L	N/A	N/A	100μA	No mosfet protection	//	No status	3Q01

Power ICS — Pre-Drivers (TMOS)

Motorola Device Number	Device Description	Main Characteristics	Package	Operating Voltage	Input Control	Output Drives High/Low Side Drive Current	Protection	Status Reporting	MC Status
MC33091	High-side, N-channel MOSFET driver for driving loads with high in-rush current — lamp driver	Single-channel high-side MOSFET driver with fault report pin	SO8	7V to 28V	1 CMOS logic	1H	SC overvoltage rev. battery	/Fault	Now
MC33198	High-side, N-channel MOSFET driver for driving loads with high in-rush current — lamp driver	Single-channel high-side MOSFET driver with 1kHz PWM capability and status report pin	SO8	7V to 20V	1 CMOS logic	1H 110µA typ.	SC overvoltage load dump	Status	Now
MC33285	Dual high-side N-channel MOSFET driver	Single channel high-side MOSFET driver with fault report pin	SO8	7V to 40V	1 analog	2H 110µA typ.	SC overvoltage load dump rev. battery	N/A	Now
MC33253	Full bridge driver with AOP for body electronic and powertrain applications	Full bridge driver, fast PWWM capability, cross conduction protection, global enable	SO28	5.5V to 55V	4 invert. 4 non-invert. CMOS, LSTTL logic	2H, 2L 1A pulse	SC overvoltage undervoltage	Current sense output ISout	1Q01
MC33883	Full bridge pre-driver for power train application	Full bridge driver, fast PWM capability, global enable	SO20	5.5V to 55V	4 non-invert. CMOS, LSTTL logic	2H, 2L 1A pulse	overvoltage undervoltage	N/A	2Q01

Peripheral and Special Function — Special Function Devices

Motorola Device Number	Device Description	Main Characteristics	Package	Operating Voltage	MC Status
MC33187	Long Duration Timer	Target application: Rear defrog long duration timer; 400mA output current capability; Integrated input debounce circuitry	8SO	5 to 18V	Now
MC33193	Direction indicator	Drive external relay, lamp failure detection, replacement of UAA1041	8SO	8 to 18V	Now
MC33197A	Wiper timer designed for harsh automotive applications. Performs the intermittent, afterwash, and continuous wiper timer functions.	Designed to drive a wiper motor relay; Adjustable time interval of less than 500ms to more than 30s; Intermittent control pin can be switched from GND to Vbat; Integrated relay driver with free wheeling protection diode	8SO	8 to 16V	Now
MC33287	Contact monitoring + dual low-side switch	Contact monitor + dual 500mA low side	SO20	2	Now
MC33884	Multiple contact monitoring	12 inputs contact monitoring (6 GND, 2 VBAT, 4 configurable), pulse wetting current Master, slave, and low-power mode INT capability	SO24	12	2Q01

Power Supply — Alternator Voltage Regulators

Motorola Device Number	Device Description	Main Characteristics	Package	Operating Voltage	MC Status
MC33092A	Alternator voltage regulator with load response control — 9SI — GM type	LRC response during initial start. Programmable LRC rates from 2.5 to 10 sec. Fault detection of undervoltage/overvoltage, phase loss and high remote sense resistance.	SOW20	4.5V to 24V	Now

Power Supply — Linear Regulators

Motorola Device Number	Device Description	Main Characteristics	Package	Bus Type and Standard	Protection	Supply	I Standby Max.	Other Features
MC33389	System base chip	Cual Vreg+LS CAN+Wdg+3 Wk up inputs	HS0P20 SO28	Low speed, dual	Fault tolerant	12V battery	150µA	Dual voltage regulator, watchdog, wakeup input, sleep

Safety and Sensors — Distributed Systems Interface Components

Device	Package	Description	Status	Bus Physical Interface	Comments	Documentation
MC68HC55	16SOIC	2-channel SPI to DSI protocol converter for bus masters	MC	—	Turns any MCU into a DSI master	MC68HC55/D
MC33790	16SOIC	2-channel DSI physical interface for bus masters	XC	—	Physical interface for DSI master nodes	Contact sales

SMARTMOS

Sensors

MOTOROLA AUTOMOTIVE SENSORS

Sensor Products Division Our focus for 2001 is on new products that will continue to meet customers' needs. The first of these new automotive sensors is our 5g and 8g Inertial Sensor devices that were released in Q1. In Q2, we are proud to announce the introduction of our new Media Resistant Automotive Pressure Sensors. The MPXAZ4100A and MPXAZ4115A use our new media resistant package. These devices can be used in automotive applications where the sensor may be in contact with destructive liquids or aggressive gases. Our popular integrated on-chip circuitry in a media resistant package is a winning combination!

Accelerometers We use surface micromachining technology for a capacitive "sensing" structure. A g-cell is coupled with a control chip for signal application, signal conditioning low-pass filter, and temperature compensation. Options for sensing directions, g-ranges, and packaging allow for design versatility and systems flexibility.

Pressure Sensors Our pressure sensors are silicon micromachined devices with integrated on-chip circuitry. These devices are ideal for microprocessor interface and are designed to perform in the automotive environment. The smaller packaging options and integrated circuit design offer alternatives to a full module solution.

Tire Pressure Monitor System (TPMS) Sensors We have comprised a Tire Pressure Monitoring System chip set which communicates using the car's Remote Keyless Entry (RKE) system. This chip set is made up of the MC68HC908RFRK2, which is a MCU+RF Transmitter housed in a single package, the MC33591, which is the RF Receiver, and the PPH6700A6, the Pressure and Temperature Sensor. The PPH6700A6 is a CMOS-based surface micromachined pressure sensor. By using a CMOS-based technology, we are able to add such features as Power Control, Battery Voltage Detection, and Wake-up. The TPM Sensor is housed in our newly designed Super Small Outline Package (SSOP).

Applications Motorola's automotive sensors are designed for a variety of applications ranging from safety and performance to comfort and control. Our sensors are used in under-hood and in-cabin applications, and are compatible with the Motorola Microcontroller Family.

Got a new idea? Our marketing and engineering support staff is ready to assist you on your new design. Call (480) 413-3333, or, for additional information, please visit:

Automotive Home Page
motorola.com/semiconductors/automotive/

Inertial Sensors⁽¹⁾

Sensing Direction	Number of Axes of Sensitivity	G-Range	AC Sensitivity	Equivalent Self-Test Output	Temperature Range	Roll-Off Frequency	Package	Status Pin	Samples
X	1	40g	50mV/g	12g	-40°C to +125°C	400Hz	SO-16	Yes	Available
X	1	100g	20mV/g	12g	-40°C to +125°C	400Hz	SO-16	Yes	Available
XY	2	50g	40mV/g	12g	-40°C to +125°C	400Hz	SO-20	Yes	LTD, full production Q3 2001
Z	1	50g	40mV/g	30g	-40°C to +125°C	400Hz	SO-16	Yes	LTD, full production Q3 2001
Z	1	100g	20mV/g	75g	-40°C to +125°C	400Hz	SO-16	Yes	Available
Z	1	250g	8mV/g	75g	-40°C to +125°C	400Hz	SO-16	Yes	Available
Z	1	5g	400 mV/g	3g	-40°C to +105°C	50Hz	SO-16	Yes	LTD, full production Q3 2001
Z	1	8g	250 mV/g	5g	-40°C to +105°C	300Hz	SO-16	Yes	LTD, full production Q3 2001

1. Motorola reserves the right to modify product specifications and/or introduction dates without any further notice. The product parameters are typical values at $V_{DD} = 5\text{ V}$ and $T = 25^\circ\text{C}$, unless otherwise specified. Other trim range specifications can be developed upon request. Please consult your Motorola sales representative.

Pressure Sensors

Device	Maximum Pressure Rating (kPa)	Full Scale Span Voltage (Typical) (Vdc)	Sensitivity (mV/kPa)	Accuracy 0–85°C (% of V _{FSS})	Package	Samples	Documentation
MPX4100A	105	4.59	54	±1.8	6-pin unibody package; 8-pin SO surface mount	Available now	MPX4100A/D
MPXA4100A	105	4.59	54	±1.8	Surface mount, small outline package (SOP)	Available now	MPX4100A/D
MPXAZ4100A	105	4.59	54	±1.8	Surface mount, small outline package (SOP) — Media Resistant Package	Available now	MPX4100A/D
MPXA4101A	102	4.59	54	±1.8	Surface mount, small outline package (SOP)	Available now	MPX4101A/D
MPX4101A	102	4.59	54	±1.8	6-pin unibody package; 8-pin SO surface mount	Available now	MPX4101A/D
MPX4115A	115	4.59	45.9	±1.5	6-pin unibody package; 8-pin SO surface mount	Available now	MPX4115A/D
MPXA4115	115	4.59	45.9	±1.5	Surface mount, small outline package (SOP)	Available now	MPX4115A/D
MPXAZ4115	115	4.59	45.9	±1.5	Surface mount, small outline package (SOP) — Media Resistant Package	Available now	MPX4115A/D
MPXV4115V	115	4.4	38.26	±1.5	Surface mount, small outline package (SOP) or DIP	Available now	MPXV4115V/D
MPX4200A	200	4.5	25.5	±1.5	6-pin unibody package	Available now	MPX4200/D
MPX4250A	250	4.7	20	±1.5	Small outline package (SOP)	Available now	MPX4250A/D
MPXV5004	4	3.9	1000	±2.5	Surface mount, small outline package (SOP) or DIP	Available now	MPXV5004G/D
MPX5010	10	4.5	450	±5.0	6-pin unibody package	Available now	MPX5010/D
MPXV5010	10	4.5	450	±5.0	8-pin, small outline package, DIP, or surface mount	Available now	MPX5010/D
MPX5100	100	4.5	4.5	±2.5	6-pin unibody package	Available now	MPX5100/D
MPX5700	700	4.5	6.4	±2.5	6-pin unibody package	Available now	MPX5700/D
MPX5999	1000	4.5	4.5	±2.5	6-pin unibody package	Available now	MPX5999D/D

Tire Pressure Monitor System (TPMS) Sensors^{(1), (2)}

Device	Maximum Pressure Rating (kPa)	Full Scale Span Voltage (Typical) (Vdc)	Sensitivity (kPa/bit)	Accuracy (–20 to 70°C)	Package	Supply Voltage (V)	Operating Modes			Samples
							Mode	Response Time (μs)	Current (μA)	
PPH6700A6	650	Digital	1.37	±7.5 kPa	Super small outline package (SSOP)	2.1 to 3.6 V	Standby/reset Measure temperature Measure pressure Output read	— 70 μs 100 μs 50 μs	0.8 μA 500 μA 1400 μA 300 μA	Evaluation Samples May 2001 Full production October 2001

1. Wake-up set at 6 second intervals.

2. Motorola reserves the right to modify product specifications and/or introduction dates without any further notice. The product parameters are typical values unless otherwise specified. Other specifications can be developed upon request. Please consult your Motorola sales representative.

THE MOTOROLA 68HC08 8-BIT MICROCONTROLLER FAMILY

68HC08 Motorola's 68HC08 Family represents one of the leading device families currently used in automotive applications and is an industry standard architecture.

Memory The 68HC08 Family offers significantly improved performance over the 68HC05, with increased C compiler code efficiency and the option of on-chip FLASH memory and EEPROM. The HC908AZ60 is the world's first 8-bit MCU with integrated FLASH programmable memory, EEPROM, and CAN/J1850.

msCAN The integrated msCAN module (available on selected devices) offers designers a cost-effective CAN controller which is compliant with parts 2.0a and 2.0b of the CAN specification.

Technology Motorola is aggressively transferring devices from 0.65 μ technology (80% UDR) to 0.5 μ technology (85% and

below UDR). A number of new devices were introduced in 2000 at 0.5 μ and more will follow in 2001.

Support and Services Motorola offers a full range of services to accompany all of our microcontrollers, which includes software development tools and device applications support.

For additional information, please visit:

Documentation

mcu.motpsps.com/documentation/index.html

(mask set errata, specifications, application notes, and other literature)

Automotive Home Page

motorola.com/semiconductors/automotive/

68HC08 Family (Sheet 1 of 2)

Device	ROM (Bytes)	RAM (Bytes)	FLASH or OTP (Bytes)	EEPROM (Bytes)	Timer	I/O	Serial	MUX	A/D	PWM	COP	Pkg Option	Oper. Voltage (V)	Oper. Freq. (MHz)	Temp.	FLASH or OTP	Avail.	Comments	Documentation
MC68HC08AB16A	16K	1K	—	512	4-CH + 4-CH 16-Bit	51	SCI SPI	—	8-CH 8-Bit	See Timer	Y	64 QFP(FU)	5.0	8.0 Max	C, V, M	908AB32	Production		MC68HC08AB16A/D
MC68HC908AB32	—	1K	32K	512	4-CH + 4-CH 16-Bit I/C, O/C, or PWM	51	SCI SPI	—	8-CH 8-Bit	See Timer	Y	64 QFP(FU)	5.0	8.0 Max	C, V, M	—	Production	Order part number SC510727.	MC68HC908AB32A/D
XC68HC908AS60A	—	2K	60K FLASH	1K	6-CH + 2-CH 16-Bit I/C, O/C, or PWM	40/46	SCI SPI	J1850 (VPW)	15-CH 8-Bit	See Timer	Y	52 PLCC(FN) 64 QFP(FU)	5.0	8.0 Max	C, V, M	908AZ60A	Production	Recommended for new design-ins.	MC68HC908AZ60A/D
XC68HC08AS32	32K	1024	—	512	6-CH + 2-CH 16-Bit I/C, O/C, or PWM	40/46	SCI SPI	J1850	8-CH 8-Bit	See Timer	Y	52 PLCC(FN) 65 QFP(FN)	5.0	8.0 Max	C, V, M	908AS60A	Production	Recommended for new design-ins.	MC68HC08AS32/D
XC68HC908AZ60A	—	2K	60K FLASH	1K	6-CH + 2-CH 16-Bit I/C, O/C, or PWM	48	SCI SPI	CAN 2.0a/2.0b	15-CH 8-Bit	See Timer	Y	64 QFP(FU)	5.0	8.0 Max	C, M, V	—	Production	Recommended for new design-ins.	MC68HC908AZ60/D

68HC08 Family (Sheet 2 of 2)

Device	ROM (Bytes)	RAM (Bytes)	FLASH or OTP (Bytes)	EEPROM (Bytes)	Timer	I/O	Serial	MUX	A/D	PWM	COP	Pkg Option	Oper. Voltage (V)	Oper. Freq. (MHz)	Temp.	FLASH or OTP	Avail.	Comments	Documentation
PC68HC08AZ32A	32K	1K	—	512	4-CH + 4-CH 16-Bit I/C, O/C, or PWM	48	SCI SPI	CAN 2.0a/2.0b	15-CH 8-Bit	See Timer	Y	64 QFP(FU)	5.0	8.0 Max	C, V, M	908AZ60A	Samples	Recommended for new design-ins. See also 16-bit XC68HC12BC32.	MC68HC08AZ32A/D
XC68HC08AZ60	60K	2K	—	1K	6-CH + 2-CH 16-Bit I/C, O/C, or PWM	48	SCI SPI	CAN 2.0a/2.0b	15-CH 8-Bit	See Timer	Y	64 QFP(FU)	5.0	8.0 Max	C, V, M	908AZ60A	Production	See also 16-bit PC68HC12D60.	MC68HC08AZ60/D
PC68HC908EY8	—	256	7680	—	Two 2-CH 16-Bit I/C, O/C, or PWM	25	ESCI SPI	LIN	8-CH 8-Bit	See Timer	Y	32 QFP	3.0, 5.0	8.0 Max	C, V, M	—	Samples Q4 01	LIN specific microcontroller, RC oscillator	Contact sales — see also LIN section
MC68HC08JL3	4K	128	—	—	2-CH 16-Bit I/C, O/C, or PWM	23	—	—	8-CH 8-Bit	See Timer	Y	28 DIP(P) 28 SOIC(DW)	3.0, 5.0	8.0 Max	C, M	908JL3	Samples	Auto qual 3Q01. RC oscillator option, LVR with selectable trip points, 6-pin LED drive. PPAP not available, MC 3Q01.	MC68HC08JL3/H
MC68HC908JL3	—	128	4K FLASH	—	2-CH 16-Bit I/C, O/C, or PWM	23	—	—	12-CH 8-Bit	See Timer	Y	28 DIP(P) 28 SOIC(DW)	3.0, 5.0	8.0 Max	C, M	—	Samples	Auto qual TBD. RC oscillator option, LVR with selectable trip points, 6-pin LED drive. PPAP not available, MC TBD.	MC68HC908JL3/H
MC68HC908RK2	—	128	2K FLASH	—	2-CH, 16-Bit	14	—	—	—	See Timer	Y	20 SOIC(DW) 20 SSOP(SD)	1.8 to 3.6	4.0 Max	C	—	Production	Low-power embedded FLASH routine	MC68HC908RK2/D
XC68HC908RF2	—	128	2K FLASH	—	1-CH, 16-Bit	12	—	—	—	See Timer	Y	32 LQFP(FA)	1.8 to 3.6	4.0 Max	C	—	Production	RF transmitter integrated	MC68HC908RF2/D

68HC08 Reference Manuals

CPU08RM/AD
TIM08RM/AD

HC08 CPU Reference Manual
HC08 Timer Reference Manual

68HC08 Emulators, Cables, and Adapters

Device	Platform	Emulation Modules	Packages Supported	Flex Cable	Target Head Adapter	Surface Mount Adapter
68HC08AS20/32/60 68HC908AS32/48/60	M68MMPFB0508 or M68MMDS0508	M68EM08AS60	52 PLCC-FN	M68CBL05C	X68TC08AX48FN52	
			64 QFP-FU	M68CBL05C	X68TC08AX48FU64	M68TQS064SAG1 ⁽²⁾ M68TQP064SA1 ⁽²⁾
68HC08AZ32/60 68HC908AZ60 68HC908AZ60A 68HC908AZ32A	M68MMPFB0508 or M68MMDS0508	M68EM08AZ60	52 PLCC-FN	M68CBL05C	X68TC08AX48FN52	
			64 QFP-FU	M68CBL05C	X68TC08AX48FU64	M68TQS064SAG1 ⁽²⁾ M68TQP064SA1 ⁽²⁾

1. Each QFP target head adapter includes one TQSOCKET with guides (M68TQSxxxSyG1) and one TQPACK disposable surface mount adapter (M68TQPxxxSy1 – 1.2-mm lead length or M68TQPxxxSyMO1 – 1.6-mm lead length). Order additional TQPACKs and TQSOCKETS (optional) using part numbers referenced in the Surface Mount Adapters column to support multiple target systems.

68HC08 Family

68HC12/68HC16 Families

THE MOTOROLA 68HC12 AND 68HC16 16-BIT MICROCONTROLLER FAMILIES

68HC12 Motorola's 68HC12 and 68HC16 Families of microcontrollers represent two of the leading device families currently used in automotive applications.

Automotive The 68HC12 Family is based around Motorola's CPU12 core and is complemented by various on-board peripherals such as memory, timers, and analog-to-digital converters as well as communications modules such as CAN, SCI, and SPI. The HC12 Family primarily is targeted at automotive applications.

Memory FLASH is the dominant memory type used by the 16-bit families. Motorola is implementing a new split-gate FLASH cell, providing great reliability benefits by using a proven technology.

MC9S12DP256 Motorola announces the introduction of a high-performance, 16-bit automotive MCU, with 256K FLASH memory, and five integrated CAN modules — the MC9S12DP256. This device is the first member of the next generation, high-performance HC12 Family. The entire Family is based on new System on a Chip Design Technology (SoCDT), which utilizes the latest synthesized design techniques, to allow faster design, production and qualification of new derivatives, all based on 0.25 μm technology. Based on the powerful

MC9S12 CPU, all Family members will be pin compatible and memory upgradable, with a variety of on-chip peripheral options. This Family continues the legacy of Motorola's best in class automotive MCUs. Full details of the 128/64/32K derivatives will be provided in the next issue of the selector guide, in line with official roll-out plan.

msCAN The integrated msCAN module (available on selected HC12 devices) offers designers a cost-effective CAN controller which is compliant with parts 2.0a and 2.0b of the CAN specification.

Service Motorola offers a full range of services to accompany all of its microcontrollers, which includes software solutions and support as well as a wide range of low-cost development tools.

For additional information, please visit:

Documentation

mcu.motps.com/documentation/index.html

(mask set errata, specifications, application notes, and other literature)

Automotive Home Page

motorola.com/semiconductors/automotive/

68HC12 Family (Sheet 1 of 2)

Device	ROM (Bytes)	RAM (Bytes)	FLASH or OTP (Bytes)	EEPROM (Bytes)	Timer	I/O	Serial	MUX	A/D	PWM	Pkg Options	Oper. Voltage (V)	Oper. Freq. (MHz)	Temp.	FLASH or OTP	Avail.	Comments	Documentation
MC9S12DP256	—	12K	256K FLASH	4K	8-CH, 16-Bit	Up to 45	2 SCI 2 SPI	Up to 5 CAN and 1 x J1850	2 x 8-CH 10-Bit	8-CH 8-Bit or 4-CH 16-Bit	112 LQFP 80 QFP	5.0	25.0	C, V, M ⁽¹⁾	—	Samples	First device as part of full family roll-out	MC9S12DP256/D
MC68HC912B32	—	1K	32K FLASH	768	8-CH, 16-Bit	Up to 63	1 SCI 1 SPI	J1850	8-CH 8-Bit	4-CH 8-Bit or 2-CH 16-Bit	80 QFP	5.0	8.0	C, V, M ⁽¹⁾	—	Production	J1850 muxed bus, BDM	MC68HC912B32/D
XC68HC912BC32	—	1K	32K FLASH	768	8-CH, 16-Bit	Up to 63	1 SCI 1 SPI	CAN 2.0a/b	8-CH 10-Bit	4-CH 8-Bit or 2-CH 16-Bit	80 QFP	5.0	8.0	C, V, M ⁽¹⁾	—	Production	MSCAN module on board, BDM	MC68HC912B32TS/D
XC68HC12BC32	32K	1K	—	768	8-CH, 16-Bit	Up to 63	1 SCI 1 SPI	CAN 2.0a/b	8-CH 8-Bit	4-CH 8-Bit	80 QFP	5.0	8.0	C, V, M ⁽¹⁾	HC912BC32	Production		MC68HC912B32TS/D

68HC12 Family (Sheet 2 of 2)

Device	ROM (Bytes)	RAM (Bytes)	FLASH or OTP (Bytes)	EEPROM (Bytes)	Timer	I/O	Serial	MUX	A/D	PWM	Pkg Options	Oper. Voltage (V)	Oper. Freq. (MHz)	Temp.	FLASH or OTP	Avail.	Comments	Documentation
MC68HC12BE32	32K	1K	—	768	8-CH, 16-Bit enhanced capture timer (ECT)	Up to 63	1 SCI 1 SPI	J1850	8-CH 10-Bit	4-CH 8-Bit or 2-CH 16-Bit	80 QFP	5.0	8.0	C, V, M ⁽¹⁾	HC912B32	Production	J1850 muxed bus	MC68HC912B32TS/D
PC68HC912D60A	—	2K	60K FLASH	1K	8-CH, 16-Bit enhanced capture timer (ECT)	Up to 66, plus up to 18 input only lines	2 SCI 1 SPI	CAN 2.0a/b	2 x 8-CH 10-Bit	4-CH 8-Bit or 2-CH 16-Bit	80 QFP ⁽²⁾ 112 LQFP	5.0	8.0	C, V, M ⁽¹⁾	—	Samples	0.5μ technology, 5V FLASH, MC plan Q2 01. Replacement for XC68HC912D60.	MC68HC912D60/D
XC68HC12D60	60K	2K	—	1K	8-CH, 16-Bit enhanced capture timer (ECT)	Up to 66, plus up to 18 input only lines	2 SCI 1 SPI	CAN 2.0a/b	2 x 8-CH 10-Bit	4-CH 8-Bit or 2-CH 16-Bit	80 QFP ⁽²⁾ 112 LQFP	5.0	8.0	C, V, M ⁽¹⁾	HC912D60A	Production		MC68HC912D60/D
MC68HC912DG128A	—	8K	128K FLASH	2K	8-CH, 16-Bit enhanced capture timer (ECT)	Up to 67, plus up to 18 input only lines	2 SCI 1 SPI	2 x CAN 2.0ab	2 x 8-CH 10-Bit	4-CH 8-Bit or 2-CH 16-Bit	112 LQFP	5.0	8.0	C, V, M ⁽¹⁾	—	Production	0.5μ technology, 5V FLASH, MC plan Q4 00. Ideal for gateway applications	MC68HC912DT128A/D
MC68HC912DT128A	—	8K	128K FLASH	2K	8-CH, 16-Bit enhanced capture timer (ECT)	Up to 67, plus up to 18 input only lines	2 SCI 1 SPI	3 x CAN 2.0a/b	2 x 8-CH 10-Bit	4-CH 8-Bit or 2-CH 16-Bit	112 LQFP	5.0	8.0	C, V, M ⁽¹⁾	—	Production	0.5μ technology, 5V FLASH. Ideal for gateway applications. Replacement for XC68HC912DG128	MC68HC912DT128A/D
PC68HC912GA32	—	2K	32K	1K	8-CH, 16-Bit, I/C, O/C, PWM, RTI	Up to 47	2 SCI, 1 SPI, CAN P/I	CAN 2.0a/b	8-CH 10-Bit	4-CH 8-Bit or 2-CH 16-Bit	80 QFP	5.0	8.0	C, V, M	—	Samples	Hyperintegration device, includes voltage regulator, CAN physical interface, and ISO9141 interface	Contact sales

M68KIT912DPQ56: Evaluation board kit for MC9S12DP256, includes evaluation boards, serial debugger interface, and evaluation compiler.

1. M temperature range limited to single-chip mode.
2. 1 x 8-CH 10-bit ATD in 80 QFP option

68HC12 Reference Manual

CPU12RM/AD

68HC12 CPU Reference Manual

68HC12/68HC16 Families

68HC16 Family

Device	ROM (Bytes)	RAM (Bytes)	FLASH (Kbytes)	Device Integration	Timers	Serial Communication	Analog	Package Options	Operating Voltage (V)	Operating Frequency (MHz)	Temperature	FLASH or OTP	Avail.	Documentation
XC68HC916Y1	0	2K+2K	48+2	SCIM	GPT+TPU	MCCI	ADC	160 QFP	5.0	16	C	—	Production	MC68HC16Y1UM/AD
MC68HC16Y1	48K	2K	0	SCIM	GPT+TPU	MCCI	ADC	160 QFP	5.0	16	C, V, M	HC916Y1	Production	MC68HC16Y1UM/AD
MC68HC916Y3	0	4K	96+4	SCIM2	GPT+TPU2	QSM MCCI	ADC	160 QFP	5.0	16	C	—	Production	MC68HC16Y3PP/D (MC68HC16Y3/916Y3UM/AD on web only)
MC68HC16Y3	96K	4K	0	SCIM2	GPT+TPU2	QSM MCCI	ADC	160 QFP	5.0	16	C, V, M	HC916Y3	Production	MC68HC16Y3PP/D (MC68HC16Y3/916Y3UM/AD on web only)
MC68HC916Y5	0	4K	160	SLIM+ACS	TPU2+CTM3	RSPI MCCI	QADC	160 QFP	5.0	20	C, V	—	Samples	Contact sales
MC68HC16Y5	160K	4K	0	SLIM+ACS	TPU2+CTM3	RSPI MCCI	QADC	160 QFP	5.0	20	C, V	HC916Y5	Samples	Contact sales
MC68HC16Z3	8K	4K	0	SIM	GPT	QSM	ADC	132 PQFP 144 LQFP	5.0	16, 20, 25	C, V, M	—	Production	MC68HC16ZUM/AD

68HC16 Reference Manuals

CPU16RM/AD
SIMRM/AD
TPURM/AD
GPTRM/AD
QSMRM/AD

68HC16 CPU Reference Manual
System Integration Module Reference Manual
Timer Processor Unit Reference Manual
General-Purpose Timer Reference Manual
Queued Serial Module Reference Manual

ADCRM/AD
CTMRM/D
MCCIRM/AD
SCIMRM/AD

Analog-to-Digital Converter Reference Manual
Configurable Timer Reference Manual
Multi-Channel Communication Interface Reference Manual
Single-Chip Integration Module Reference Manual

MOTOROLA LOCAL INTERCONNECT NETWORK (LIN) SOLUTIONS

Motorola and LIN As the only semiconductor member of the LIN consortium, Motorola has the industry's most advanced range of components, software, tools, and support available.

Cost Benefits from LIN A LIN sub-bus system uses a single-wire implementation and self-synchronization, without a crystal or ceramic resonator, in the slave node. With these cost benefits, high-end comfort and convenience features no longer need to be limited only to top-of-the-line cars.

Embedded Controllers Since the LIN sub-bus is based on common UART/SCI interface hardware, the 8-bit 68HC05, 68HC08, 68HC11, and 16-bit 68HC12 Families provide the industry's broadest range of performance and features, affording designers the freedom to choose parts ideally suited to their needs.

Advanced Integration with LIN Microcontrollers will evolve in the LIN environment to integrate the voltage regulator, physical interface, and high-voltage I/O to provide space, cost, and reliability benefits. Motorola's hyperintegration and Mechatronics solutions provide this capability today.

Software for LIN Motorola is working closely with the leading LIN tool supplier to ensure a first class, seamless development and debug environment for Motorola LIN products.

68HC908EY8 Motorola is pleased to announce the design of the first in a new family of dedicated LIN devices, the 68HC908EY8. A member of the high-performance HC08 Family of 8-bit MCUs, the 68HC908EY8 is based in 0.5- μ m technology and includes all of the peripherals necessary for a wide range of LIN applications, whether master or slave. Device peripheral features include an Enhanced Serial Communications Interface (ESCI) and stable on-chip RC Oscillator with an accuracy of 2% the key to synchronization with the LIN protocol bus.

For additional information, please visit:

LIN Home Page
www.lin-subbus.org/

Automotive Home Page
motorola.com/semiconductors/automotive/

LIN Software Products

Product	68HC05	68HC08	68HC12	MC9S12DP256
LIN Master		Now	Now	2Q 2001
LIN Slave	Now	Now	Now	3Q 2001
Operating System		Now	Now	2Q 2001

LIN Physical Interface

Device	Supply	Wakeup	Sleep Mode	Slew Rate	I Standby Max
MC33399D	7 V to 27 V	Several Modes	Yes	1 to 2 V/ μ s	50 μ A

Local Interconnect Network

Local Interconnect Network

Hyperintegration / Mechatronics LIN Slave MCUs

Device	ROM (Bytes)	RAM (Bytes)	FLASH (Bytes)	EEPROM (Bytes)	Timer	Pkg Option	Comments	Documentation
MC68HC05PV8	8K	192	—	128	15-Bit 16-Bit 2I/C, 2O/C	28 SOIC(DW)	Timer, PWM, A/D, Oscillator, Vreg, HV I/O, op amp, physical I/F	M68HC05PV8/D
MC68HC05PV8A	8K	192	—	128	15-Bit 16-Bit 2I/C, 2O/C	28 SOIC(DW)	Hyperintegration device, 100 μ A stop I _{DD} current	M68HC05PV8/D
MC68HC805PV8	—	192	8K	128	15-Bit 16-Bit 2I/C, 2O/C	28 SOIC(DW)	Timer, PWM, A/D, Oscillator, Vreg, HV I/O, op amp, physical I/F, relay drivers	M68HC05PV8/D
MC33393TM	—	64	—	1K	16-Bit	SO8	Timer, oscillator, 2 x 175 mA H-bridge, mechatronics	Contact sales for product reviews

LIN Slave MCUs

Device	ROM (Bytes)	RAM (Bytes)	FLASH or OTP (Bytes)	EEPROM (Bytes)	Timer	I/O	Serial	A/D	PWM	COP	Pkg Option	Oper. Voltage (V)	Oper. Freq. (MHz)	Temp.	FLASH or OTP	Avail.	Comments	Documentation
XC68HC908JL3	—	128	4K FLASH	—	2-CH 16-Bit I/C, O/C, or PWM	23	—	12-CH 8-Bit	See Timer	Y	28 DIP(P) 28 SOIC(DW)	3.0, 5.0	8.0 Max	C, M	—	Samples (TBD)	Automotive qual TBD RC oscillator option, LVR w/ selectable trip points, 6-pin LED drive	MC68HC908JL3/H
PC68HC08AB16A	16K	512	—	—	4-CH + 2-CH 16-Bit I/C, O/C, or PWM	51	SCI SPI	8-CH 8-Bit	See Timer	Y	28 QFP	5.0	8.0 Max	C, V, M	—	Production		MC68HC08AB16A/D
MC68HC908AB32	—	1K	32K	512	4-CH + 4-CH, 16-Bit I/C, O/C, or PWM	51	SPI, SCI	8-CH 8-Bit	See Timer	Y	64 QFP (FU)	5.0	8.0 Max	C, V, M	—	Production	Order # SC510727	MC68HC908AB32A/D
PC68HC908EY8	—	256	8K FLASH	—	2 x 2-CH 16-Bit I/C, O/C, or PWM	Up to 25	SPI, ESCI	8-CH 8-Bit	See Timer	Y	32 QFP	3.3, 5.0	8.0 Max	C, V, M	—	Samples Q4 01	LIN-specific microcontroller: ESCI (enhanced SCI) capable of 13 bit break detect	Contact sales
MC68HC08JL3	4K	128	—	—	2-CH 16-Bit I/C, O/C, or PWM	23	—	8-CH 8-Bit	See Timer	Y	28 DIP(P) 27 SOIC(DW)	3.0, 5.0	8.0 Max	C, M	908JL3	Samples	Automotive qual TBD RC oscillator option, LVR with selectable trip points, 8-pin LED drive	MC68HC08JL3/H

Hyperintegration / Mechatronics LIN Master MCUs

Device	ROM (Bytes)	RAM (Bytes)	FLASH or OTP (Bytes)	EEPROM (Bytes)	Timer	I/O	Serial	A/D	PWM	COP	Pkg Option	Oper. Voltage (V)	Oper. Freq. (MHz)	Temp.	OTP	Avail.	Comments	Documentation
PC68HC912GA32	—	2K	32K FLASH	1 K	8-CH 16-Bit I/C, O/C, PWM, RTI	Up to 47	2 SCI 1 SPI CAN P/I	8-CH 10-Bit	4-CH 8-Bit or 2-CH 16-Bit	Y	80 QFP	—	8.0	C, V, M	—	Samples	Hyperintegration device, includes voltage regulator, CAN physical interface, and ISO9141 interface	Contact sales

LIN Master MCUs

Device	ROM (Bytes)	RAM (Bytes)	FLASH or OTP (Bytes)	EEPROM (Bytes)	Timer	I/O	Serial	A/D	Mux	PWM	COP	Pkg Option	Oper. Voltage (V)	Oper. Freq. (MHz)	Temp.	OTP	Avail.	Comments	Documentation
XC68HC908AZ60A	—	2K	60K FLASH	1K	6-CH + 2-CH 16-Bit I/C, O/C, or PWM	48	SCI SPI	15-CH 8-Bit	CAN 2.0a/2.0b	See Timer	Y	64 QFP(FU)	5.0	8.0 Max	C, V, M	—	Production	Recommended for new design-ins.	MC68HC908AZ60A/D
PC68HC08AZ32A	32K	1K	—	512	4-CH + 4-CH 16-Bit I/C, O/C, or PWM	48	SCI SPI	15-CH 8-Bit	CAN 2.0a/2.0b	See Timer	Y	64 QFP(FU)	5.0	8.0 Max	C, V, M	908AZ60A	Samples	Recommended for new design-ins. CAN 2.0a and 2.0b	MC68HC08AZ32A/D
MC9S12DP256	—	12K	256K FLASH	4 K	8-CH 16-Bit	Up to 45	2 SCI 1 SPI	2 x 8-CH 10-Bit	Up to 5 CAN and 1 x J1850	8-CH 8-Bit or 4-CH 16-Bit	Y	112 LQFP 80 QFP	5.0	25.0	C, V, M ⁽¹⁾	—	Samples	First device as part of full family roll-out	MC9S12DP256/D http://www.mot-sps.com/automotive
MC68HC912B32	—	1K	32K FLASH	768	8-CH 16-Bit I/C or O/C, RTI, Pulse Accumulator	Up to 63	SCI SPI	8-CH 8-Bit	J1850	4-CH 8-Bit or 2-CH 16-Bit	Y	80 QFP(FU)	5.0	8.0 Max	C, V, M	—	Production	J1850, muxed bus, BDM	MC68HC912B32/D
MC68HC12BE32	32K	1K	—	768	8-CH 16-Bit I/C or O/C, RTI, Pulse Accumulator	Up to 63	SCI, SPI	8-CH 10-Bit	CAN J1850	4-CH 8-Bit or 2-CH 16-Bit	Y	80 QFP(FU)	5.0	8.0 Max	C, V, M	—	Production	BDM, enhanced timer	MC68HC912B32/D
XC68HC912BC32	—	1K	32K FLASH	768	8-CH 16-Bit I/C or O/C, RTI, Pulse Accumulator	Up to 63	SCI, SPI	8-CH 10-Bit	CAN J1850	4-CH 8-Bit or 2-CH 16-Bit	Y	80 QFP(FU)	5.0	8.0 Max	C, V, M	—	Production	msCAN CAN 2.0a and 2.0b, BDM	MC68HC912B32TS/D
PC68HC912D60A	—	2K	60K FLASH	1 K	8-CH 16-Bit Enhanced Capture Timer (ECT)	Up to 66, plus up to 18 input-only lines	2 SCI 1 SPI	2 x 8-CH 10-Bit	CAN 2.0a/2.0b	4-CH 8-Bit or 2-CH 16-Bit	Y	112 QFP	5.0	8.0	C, V, M ⁽¹⁾	—	Samples Q2 01	0.5μ technology, 5V FLASH, MC plan Q2 01	MC68HC912D60/D
MC68HC912DG128A	—	8K	128K FLASH	2 K	8-CH 16-Bit Buffered Input Captures	Up to 67, plus up to 18 input-only lines	2 SCI 1 SPI	2 x 8-CH 10-Bit	2 x CAN 2.0a/2.0b	4-CH 8-Bit or 2-CH 16-Bit	Y	112 LQFP	5.0	8.0	C, V, M ⁽¹⁾	—	Production	0.5μ technology, 5V FLASH, ideal for gateway applications	MC68HC912DT128A/D
MC68HC912DT128A	—	8K	128K FLASH	2 K	8-CH 16-Bit Buffered Input Captures	Up to 67, plus up to 18 input-only lines	2 SCI 1 SPI	2 x 8-CH 10-Bit	3 x CAN 2.0a/2.0b	4-CH 8-Bit or 2-CH 16-Bit	Y	112 LQFP	5.0	8.0	C, V, M ⁽¹⁾	—	Production	0.5μ technology, recommended for new design-ins, 5V FLASH, ideal for gateway applications	MC68HC912DT128A/D
XC68HC12D60	60K	2K	—	1K	8-CH, 16-Bit enhanced capture timer (ETC)	Up to 66, plus up to 18 input only lines	2 SCI 1 SPI	2 x 8-CH 10-Bit	CAN 2.0a/2.0b	4-CH 8-Bit or 2-CH 16-Bit	Y	80 QFP 112 LQFP	5.0	8.0	C, V, M ⁽¹⁾	912DG60A	Production		MC68HC912D60/D

1. M temperature range limited to single-chip mode.

Local Interconnect Network

THE MOTOROLA 68HC05 AND 68HC11 8-BIT MICROCONTROLLER FAMILIES

68HC05 and 68HC11 Motorola's 68HC05 and 68HC11 Families represents two of the leading device families currently used in automotive applications.

Automotive The 68HC05 and 68HC11 Families are complemented by various on-board peripherals such as memory, as well as timers and analog-to-digital converters. Targeted at many applications including body electronics applications, air conditioning, and window lift, the 68HC05 and 68HC11 Families also are widely used in many white good or non-automotive applications.

Memory The 68HC05 and 68HC11 Families have several memory options such as ROM, EEPROM, and OTP.

Service Motorola offers a full range of services to accompany all of our microcontrollers which include software solutions and support as well as suitable development tools.

For additional information, please visit:

Documentation

mcu.motpsps.com/documentation/index.html

(mask set errata, specifications, application notes, and other literature)

Automotive Home Page

motorola.com/semiconductors/automotive/

68HC05 Family (Sheet 1 of 2)

Device	ROM (Bytes)	RAM (Bytes)	FLASH or OTP (Bytes)	EEPROM (Bytes)	Timer	I/O	Serial	MUX	A/D	PWM	COP	Pkg Option	Oper. Voltage (V)	Oper. Freq. (MHz)	Temp.	FLASH or OTP	Avail.	Comments	Documentation
MC68HC705B16	—	352	14.8K	256	16-Bit 2 I/C, 2 O/C	32	SCI See comment	—	8-CH 8-Bit	2-CH 8-Bit	Y	52 PLCC(FN) 64 QFP(FU)	3.3, 5.0	2.1	C, V, M	—	Production	705B32 has OTP for SDIP, SCI has synchronous master SPI like capability	MC68HC05B6/D
MC68HC05B6	5.8K	176	—	256	16-Bit 2 I/C, 2 O/C	32	SCI See comment	—	8-CH 8-Bit	2-CH 8-Bit	Y	56 SDIP(B) 52 PLCC(FN) 64 QFP(FU)	3.3, 5.0	4.0	C, V, M	705B16 705B32	Production	SCI has synchronous master SPI like capability	MC68HC05B6/D
MC68HC05B8	7K	176	—	256	16-Bit 2 I/C, 2 O/C	32	SCI See comment	—	8-CH 8-Bit	2-CH 8-Bit	Y	56 SDIP(B) 52 PLCC(FN) 64 QFP(FU)	3.3, 5.0	4.0	C, V	705B16 705B32	Production	SCI has synchronous master SPI like capability	MC68HC05B6/D
MC68HC05B16	14.75K	352	—	256	16-Bit 2 I/C, 2 O/C	32	SCI See comment	—	8-CH 8-Bit	2-CH 8-Bit	Y	56 SDIP(B) 52 PLCC(FN) 64 QFP(FU)	3.3, 5.0	4.0	C, V, M	705B16 See comment	Production	SCI has synchronous master SPI like capability. See also MC68HC08AB16A	MC68HC05B6/D
MC68HC05B32	32K	528	—	256	16-Bit 2 I/C, 2 O/C	32	SCI See comment	—	8-CH 8-Bit	2-CH 8-Bit	Y	56 SDIP(B) 52 PLCC(FN) 64 QFP(FU)	3.3, 5.0	2.1	See comments	705B32	Production	SCI has synchronous master SPI like capability 0–70°C temp. only for SDIP; –40 to +85 for PLCC/QFP	MC68HC05B6/D
MC68HC05C8A	8K	176	—	—	16-Bit 1 I/C, 1 O/C	31	SCI SPI	—	—	—	Y	40 DIP(P) 42 SDIP(B) 44 PLCC(FN) 44 QFP(FB)	3.3, 5.0	4.0	C, V	705C8A	Production	High-speed select on RVU header, low-voltage 2.4V to 3.6V @ 1MHz, bus available	HC05C8AGRS/D

68HC05 Family (Sheet 2 of 2)

Device	ROM (Bytes)	RAM (Bytes)	FLASH or OTP (Bytes)	EEPROM (Bytes)	Timer	I/O	Serial	MUX	A/D	PWM	COP	Pkg Option	Oper. Voltage (V)	Oper. Freq. (MHz)	Temp.	FLASH or OTP	Avail.	Comments	Documentation
MC68HC705C9A	—	352	16K	—	16-Bit 1 I/C, 1 O/C	31	—	—	—	—	Y	40 DIP(P) 42 SDIP(B) 44 PLCC(FN) 44 QFP(FB)	3.3, 5.0	2.1	C	—	Production	'A' features	HC705C9AGRS/D
MC68HC705P6A	—	176	4.5K	—	16-Bit 1 I/C, 1 O/C	21	SIOP	—	4-CH 8-Bit	—	Y	28 DIP(P) 28 SOIC(DW)	3.3, 5.0	2.1	C	—	Production	Umbrella OTP for P1A, P4A, and P9A. See also FLASH MC68HC908JL3	HC705P6AGRS/D
MC68HC05P6	4.5K	176	—	—	16-Bit 1 I/C, 1 O/C	21	SIOP	—	4-CH 8-Bit	—	Y	28 DIP(P) 28 SOIC(DW) 28 SSOP (SD)	3.3, 5.0	2.1	C, V, M	705P6A	Production	See also FLASH MC68HC908JL3	MC68HC05P6/D MC68HC05P6AD/D
XC68HC805P18B	—	192	—	8K +128	16-Bit 1 I/C, 1 O/C	20	SIOP	—	4-CH 8-Bit	—	Y	28 DIP(P) 28 SOIC(DW)	—	—	C	—	Production		HC805P18GRS/D
MC68HC805PV8	—	192	8K EEPROM	128	15-Bit 16-Bit 2 I/C, 2 O/C	20	—	—	6-CH 8-Bit	1-CH	Y	28 SOIC(DW)	3.3, 5.0	2.1	C, V, M	805PV8	Production	4.2MHz high speed available; on-chip 40mVreg.; hyperintegration device	HC05PV8GRS/D
MC68HC05PV8A	8K	192	—	128	15-Bit 16-Bit 2 I/C, 2 O/C	20	—	—	6-CH 8-Bit	1	Y	28 SOIC(DW)	3.3, 5.0	2.1	C, V, M	805PV8	Production	Hyperintegration device	HC05PV8GRS/D
XC68HC705X4	—	176	4K	—	16-Bit 1 I/C, 1 O/C	16	—	CAN	—	—	Y	28 SOIC(DW)	5.0	2.1	C	—	Production	2MHz bus speed only	MC68HC05X4/D
MC68HC05X4	4K	176	—	—	16-Bit 1 I/C, 1 O/C MFI, RTI	16	—	CAN	—	—	Y	28 SOIC(DW)	5.0	2.1	C	705X4 (limited)	Production	2MHz bus speed only	MC68HC05X4/D
MC68HC705X32	—	528	32K	256	16-Bit 2 I/C, 2 O/C	32	SCI	CAN	8-CH 8-Bit	2-CH 8-Bit	Y	64 QFP(FU)	5.0	4.0	C, V, M	—	Production	4MHz bus speed available See also FLASH MC68HC908AB32	MC68HC05X16/D
MC68HC05X16	14.75K	352	—	256	16-Bit 2 I/C, 2 O/C	32	SCI	CAN	8-CH 8-Bit	2-CH 8-Bit	Y	64 QFP(FU)	—	2.1	C, V, M	705X32	Production	2MHz bus speed only. See also MC68HC08AB16A	MC68HC05X16/D
MC68HC05X32	—	528	32K	256	16-Bit 2 I/C, 2 O/C	32	SCI	CAN	8-CH 8-Bit	2-CH 8-Bit	Y	64 QFP(FU)	5.0	2.1	C, V, M	—	Production	4MHz bus speed available. See also FLASH MC68HC908AB32	MC68HC05X16/D

68HC05 Reference Manuals

M68HC05AG/AD
M68HC05TB/D

Applications Guide
Understanding Small Microcontrollers Text Book

68HC11 Family

THE MOTOROLA 68HC11 8-BIT MICROCONTROLLER FAMILY

68HC11 Family (Sheet 1 of 2)

Device	ROM (Bytes)	RAM (Bytes)	FLASH or OTP (Bytes)	EEPROM (Bytes)	Timer	I/O	Serial	A/D	PWM	Pkg Options	Oper. Voltage (V)	Oper. Freq. (MHz)	Temp.	FLASH or OTP	Avail.	Comments	Documentation
MC68HC11D0	—	192	—	—	16-Bit, 3/4IC, 4/5OC, RTI, pulse accumulator, watchdog	32	SPI SCI	—	—	40 PDIP 44 QFP 44 PLCC	3.0, 5.0	3.0 Max	C, V, M	—	Production	64K external address bus, low-voltage version available	MC68HC11D3/D
MC68HC711D3	—	192	4K	—	16-Bit, 3/4IC, 4/5OC, RTI, pulse accumulator, watchdog	32	SPI SCI	—	—	40 PDIP 44 PLCC 44 QFP 44 CLCC	5.0	3.0 Max	C, V, M	—	Production	64K external address bus, 3MHz, C temperature. See also FLASH MC68HC908JL3	MC68HC711D3/D
MC68HC11D3	4K	192	—	—	16-Bit, 3/4IC, 4/5OC, RTI, pulse accumulator, watchdog	32	SPI SCI	—	—	40 PDIP 44 QFP 44 PLCC	3.0, 5.0	3.0 Max	C, V, M	711D3	Production	64K external address bus See also FLASH MC68HC908JL3	MC68HC11D3/D
MC68HC711E9	—	512	12K	512	16-Bit, 3/4IC, 4/5OC, RTI, pulse accumulator	38	SPI SCI	8-CH 8-Bit	—	52 PLCC 52 CLCC 64 QFP	5.0	3.0 Max	C, V, M	—	Production	EEPROM block protect 4MHz available, contact factory	MC68HC11E/D
MC68HC711E20	—	768	20K	512	16-Bit, 3/4IC, 4/5OC, RTI, pulse accumulator	38	SPI SCI+	8-CH 8-Bit	—	52 PLCC 64 QFP 52 CLCC	5.0	4.0 Max	C, V, M	—	Production	4MHz available, contact factory See also FLASH MC68HC908AB32	MC68HC11E/D
MC68HC11E20	20K	768	—	512	16-Bit, 3/4IC, 4/5OC, RTI, pulse accumulator	38	SPI SCI+	8-CH 8-Bit	—	52 PLCC 64 QFP 52 CLCC	5.0	3.0 Max	C, V, M	711E20	Production	4MHz available, contact factory See also FLASH MC68HC908AB32	MC68HC11E/D
MC68HC11F1	—	1K	—	512	16-Bit, 3/4IC, 4/5OC, watchdog, RTI, pulse accumulator	30	SPI SCI	8-CH 8-Bit	—	68 PLCC 80 LQFP	3.0, 5.0	5.0 Max	C, V, M	—	Production	64K external address bus, 4 programmable chip selects, 4MHz non-mux address/data bus, low-voltage version	MC68HC11F1/D
MC68HC11FC0	—	1K	—	—	6-Bit, 3/4IC, 4/5OC, watchdog, RTI, pulse accumulator	—	SPI SCI	—	—	80 LQFP 64 QFP	3.0, 5.0	5.0 Max	C	—	Production	64K external address bus, 4 programmable chip selects, extra pair of power/GND pins	MC68HC11F1/D
MC68HC11K0	—	768	—	—	16-Bit, 3/4IC, 4/5OC, RTI, pulse accumulator	62	SPI SCI+	8-CH 8-Bit	4-CH 8-Bit or 2-CH 16-Bit	84 PLCC 80 QFP	3.0, 5.0	4.0 Max	C, V, M	—	Production	5MHz non-mux bus, extended memory map, 4 chip selects	MC68HC11K4/D
MC68HC11K1	—	768	—	640	16-Bit, 3/4IC, 4/5OC, RTI, pulse accumulator	62	SPI SCI+	8-CH 8-Bit	4-CH 8-Bit or 2-CH 16-Bit	84 PLCC 80 QFP	3.0, 5.0	4.0 Max	C, V, M	—	Production	5MHz non-mux bus, extended memory map, 4 chip selects	MC68HC11K4/D
MC68HC11K4	24K	768	—	640	16-Bit, 3/4IC, 4/5OC, RTI, pulse accumulator	62	SPI SCI+	8-CH 8-Bit	4-CH 8-Bit or 2-CH 16-Bit	84 PLCC 80 QFP	3.0, 5.0	4.0 Max	C, V, M	711K4 (limited)	Production	5MHz non-mux bus, extended memory map, 4 chip selects See also FLASH MC68HC908AB32	MC68HC11K4/D

68HC11 Family (Sheet 2 of 2)

Device	ROM (Bytes)	RAM (Bytes)	FLASH or OTP (Bytes)	EEPROM (Bytes)	Timer	I/O	Serial	A/D	PWM	Pkg Options	Oper. Voltage (V)	Oper. Freq. (MHz)	Temp.	FLASH or OTP	Avail.	Comments	Documentation
MC68HC711KS2	—	1K	32K	640	16-Bit, 3/4IC, 4/5OC, RTI, pulse accumulator	51	SPI+ SCI+	8-CH 8-Bit	4-CH 8-Bit or 2-CH 16-Bit	68 PLCC 80 LQFP	5.0	4.0 Max	C, V, M	—	Production	4MHz non-mux bus, no MMU, no chip selects, low-power mode, security option available See also FLASH MC68HC908AB32	MC68HC11K/D
MC68HC11KS2	32K	1K	—	640	16-Bit, 3/4IC, 4/5OC, RTI, pulse accumulator	51	SPI+ SCI+	8-CH 8-Bit	4-CH 8-Bit or 2-CH 16-Bit	68 PLCC 80 LQFP	5.0	4.0 Max	C, V, M	711KS2	Production	4MHz non-mux bus, no MMU, no chip selects, low-power mode, security option available See also FLASH MC68HC908AB32	MC68HC11K/D
MC68HC11KW1	—	768	—	640	16-Bit, 3/4IC, 4/5OC, RTI, pulse accumulator	80	SPI+ SCI+	10-CH 10-Bit	4-CH 8-Bit	100 LQFP	5.0	4.0 Max	C	—	Production	4MHz non-mux bus, 2 extra timers, 4 chip selects, extended memory map	MC68HC11KW1/D
MC68HC711P2	—	1K	32K	640	16-Bit, 3/4IC, 4/5OC, RTI, pulse accumulator	62	Triple SPI SCI	8-CH 8-Bit	4-CH 8-Bit	84 PLCC	5.0	4.0 Max	C	—	Production	64K external address bus, MI-bus interface, PLL clock circuitry See also FLASH MC68HC908AB32	MC68HC11P2/D

68HC11 Reference Manual

M68HC11RM/AD

68HC11 Reference Manual

683XX/PowerPC Families

32-Bit Legacy Motorola's PowerPC™ and MC683XX Families of microcontrollers (MCU) represent two of the leading device families currently used in automotive applications.

Automotive At the heart of the industry's smartest automotive systems is the PowerPC 32-bit RISC core, a high-performance MCU that provides customers with added performance to tackle increasingly complex control functions. The PowerPC Family is code compatible and complemented by various on-board peripherals such as memory, timers, and analog-to-digital converters as well as communications modules such as CAN, SCI, and SPI.

Memory FLASH is the dominant memory type used by the 32-bit families. Motorola is implementing a new split-gate FLASH cell, providing great reliability benefits by using a proven technology.

MPC565 The MPC565 is the latest addition to the automotive PowerPC Family whose success accelerated in 1998 with the introduction of the MPC555. The MPC565 has been designed

specifically for the harsh automotive environment and offers the high performance of a 56MHz PowerPC core and advanced peripheral features all integrated with 1M of FLASH memory on a single chip. Leading the MPC500 Family in functionality and integration, the MPC565 extends Motorola's portfolio of high-power embedded MCUs available to the automotive market.

Service Motorola offers a full range of services to accompany all of its microcontrollers, along with software solutions, support, and a wide range of low-cost development tools.

For additional information, please visit:

Documentation

<http://mcu.motps.com/documentation/index.html>

(mask set errata, specifications, application notes, and other literature)

Automotive Home Page

<http://www.mot-sps.com/automotive/>

PowerPC Family

Device	ROM (Bytes)	RAM (Bytes)	FLASH (Bytes)	Device Integration	Timer	Serial	MUX	A/D	PWM	Operating Voltage	Operating Frequency (MHz)	Temp.	Package Options	Comments	Documentation
MPC555/6	0	26K + 6K for TPUs	448K	USIU	50-channel timer system: 2 TPU3 + MIOS1	QSMCM (2 SCI + QSPI) + 2 TOUCAN	2 x TOUCAN	2 QADC64 (10-Bit A/D with 64 result registers on each)	8 x PWM	3.3Vdc for core, 5.0Vdc for FLASH	40	M	272 PBGA	Production available now MPC556 offers code compression support	MPC555UM/AD TPURM/AD RCPURM/AD
MPC561/2	0	32K + 8K for TPU + 2K for DECRAM	0	USIU	54-channel timer system: 2 TPU3 + MIOS14	QSMCM (2 SCI + 1 QSPI) + 3 TOUCAN	3 x TOUCAN	2 QADC64E (10-Bit A/D with 64 result registers each) 32 channels on chip	12 x PWM	2.6Vdc for core, 5.0Vdc for A/D and I/O	40 or 56	M	388 PBGA	Samples 2H 2001 MPC562 offers code compression support	MPC561UM/AD TPURM/AD RCPURM/AD
MPC563/4	0	32K + 8K for TPU + 2K for DECRAM	512K	USIU	54-channel timer system: 2 TPU3 + MIOS14	QSMCM (2 SCI + 1 QSPI) + 3 TOUCAN	3 x TOUCAN	2 QADC64E (10-Bit A/D with 64 result registers each) 32 channels on chip	12 x PWM	2.6Vdc for core, 5.0Vdc for A/D and I/O	40 or 56	M	388 PBGA	Samples 2H 2001 MPC564 offers code compression support	MPC561UM/AD TPURM/AD RCPURM/AD
MPC565/6	0	36K + 10K for TPU + 4K for DECRAM	1M	USIU	70-channel timer system: 3 TPU3 + MIOS14	QSMCMx2 (4 SCI + 2 QSPI) + 3 TOUCAN	3 x TOUCAN	2 QADC64E (10-Bit A/D with 64 result registers each) 40 channels on chip	12 x PWM	2.6Vdc for core, 5.0Vdc for A/D and I/O	40 or 56	M	388 PBGA	Samples 2H 2001 MPC566 offers code compression support	MPC565UM/AD TPURM/AD RCPURM/AD

Device	Processor Speed (Typ)	Drystone Performance (MIPS)	Microprogrammable Module	Translation Lookaside Buffers	FPU Floating Point Unit	Parallel (Bits)	Power Dissipation (Typ)	Miscellaneous Peripherals	Cache-L1 Instructional	Cache-L1 Data
MPC823E	81 MHz	105 + 80 MHz	CPM	8-entry	—	53	170 m @ 25 MHz	2 UARTs, 1 IC, 1 SPI, USB	16 KBytes	8 KBytes

M•CORE Devices

Device	ROM or EPROM (Bytes)	RAM (Bytes)	EEPROM (Bytes)	Timer	Serial	A/D	Operating Voltage (V)	Operating Frequency (MHz)	Temperature	Package Options	Available	MC
MMC2103	64K FLASH	2K SRAM	0	16-Bit, 2-CH PWM, 4-CH DASM	QSPI, QSCI, SCI, BDLC, DSIM, CAN	10-Bit, 10-CH QADC	3.3, 5	33	C, V, M	100 QFP	Production	1H01
MMC2107	128K FLASH	8K SRAM	0	Dual 4-CH capture/compare, 3-CH PWM	SCI	10-Bit, 8-CH QADC	3.3, 5	33		100 LQFP 144 LQFP	Production	PPAP not available
MMC2111	128K FLASH	4K SRAM	0	16-Bit, 2-CH PWM, 4-CH DASM	QSPI, QSCI, SCI, BDLC, DSIM, CAN, SPI	10-Bit, 10-CH QADC	3.3, 5	33	C, V, M	112 QFP	Samples	2H01

683XX Family

Device	ROM (Bytes)	RAM (Bytes)	FLASH (Bytes)	Device Integration	Timer	Serial	A/D	Operating Voltage (V)	Operating Frequency (MHz)	Temperature	Package Options	Avail.	Comments	Documentation
MC68332	0	2K	0	SIM	TPU	QSM	—	5.0	16, 20, 25	C, V, M	132 PQFP 144 LQFP	Production		MC68332UM/AD MC68LK332EC16/D SCIMRM/AD
MC68336	0	4K+3.5K	0	SIM	TPU CTM4	QSM	QADC	5.0	20, 25	C, V, M	160 QFP	Production		MC68336/376PP/D MC68336/376UM/AD SCIMRM/AD
MC68F375	8K	6K TPU 8K SRAM	256K	SCIM2	CTM9 TPU3	2 SCI TOUCAN Queued SPI	QADC64/ AMUX	3.3, 5.0	33	M	217 PBGA	Production		MC683F375UM/AD SCIMRM/AD
MC68376	8K	4K+3.5K	0	SIM	TPU CTM4	QSM TOUCAN	QADC	5.0	20, 25	C, V, M	160 QFP	Production		MC68336/376PP/D MC68336/376UM/AD SCIMRM/AD

683xx Reference Manuals

CPU32RM/AD
SIMRM/AD
TPURM/AD
GPTRM/AD

CPU32 Reference Manual
System Integration Module Reference Manual
Timer Processor Unit Reference Manual
General-Purpose Timer Reference Manual

QSMRM/AD
ADCRM/AD
CTMRM/D
SCIMRM/D

Queued Serial Module Reference Manual
Analog-to-Digital Converter Reference Manual
Configurable Timer Reference Manual
Single-Chip Integration Module Reference Manual

Automotive Door System Example

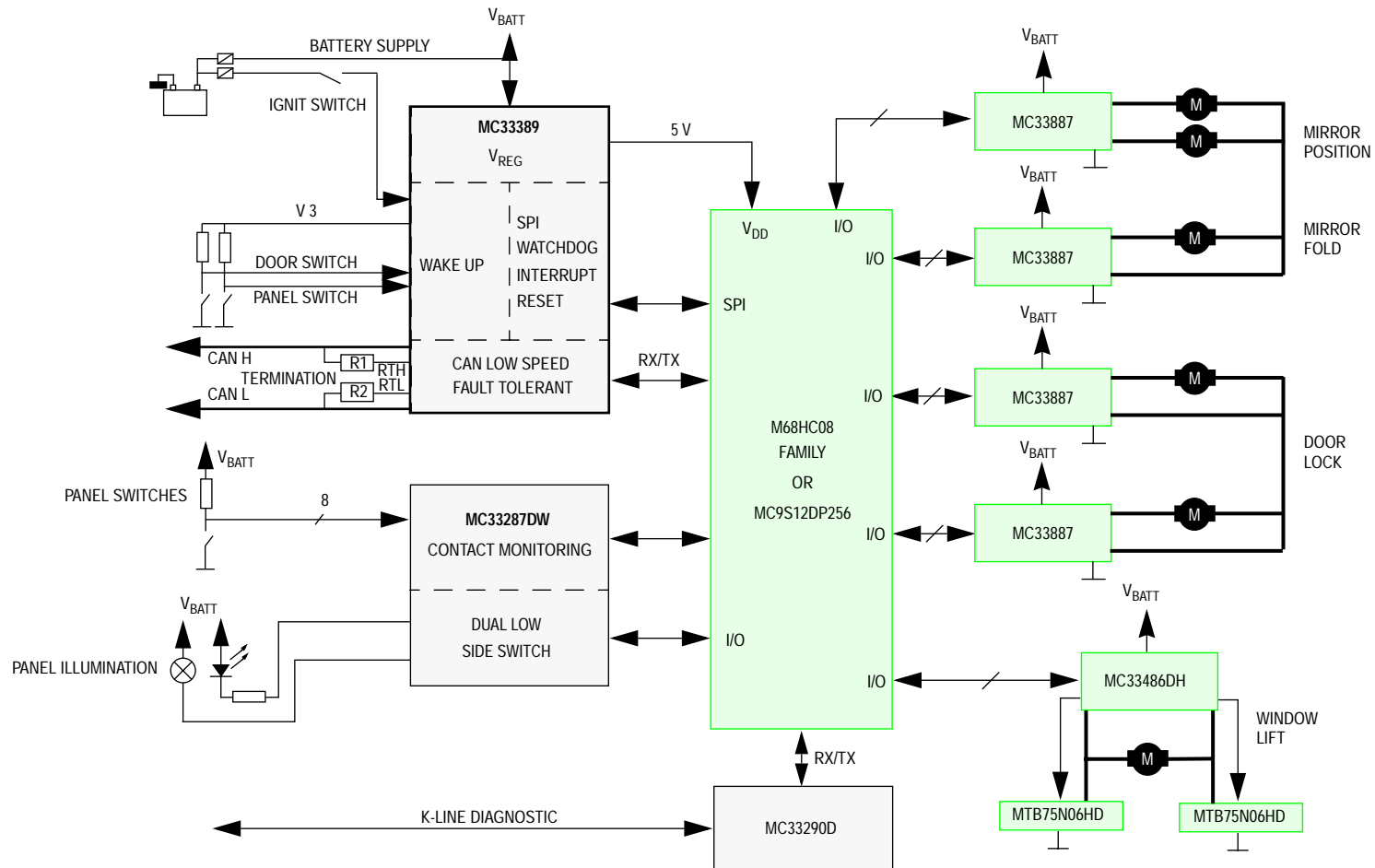

Device Application	Suggested Device	Device Highlights
System basis chip with CAN XSCVR, 2V-regulators, reset, IRQ	MC33889	SPI, CAN low-speed tolerant physical interface (125kbps)
Contact monitoring and dual low-side protected driver	MC33287DW	Parallel interface, $V_{BDSS} = 65V$, $R_{DSON} = 1.4\Omega$, $I_{Load} = 0.5A$
LIN physical interface	MC33399D	Supply 7V to 27V, several wakeup modes, sleep mode, slew rate 1 to 2V/ μ s
Microcontroller	MC9S12DP256	256K FLASH, 12K RAM, 4K EEPROM, up to 5 CAN and 1 J1850, 2 x SPI, 2 x SCI
Microcontroller	XC68HC908AZ60A	60K FLASH, 2K RAM, 1K EEPROM, CAN, 64 QFP(FU), 0.5 μ device
Motor driver/controller	MC33186DH1R2	150M Ω H-bridge driver, $V_{BDSS} = 40V$, $R_{DSON} = 0.15\Omega$
High-side driver	MC33486DH	Motor control with diagnostics and current recopy function, H-bridge, $V_{BDSS} = 40V$, $R_{SDON} = 15M\Omega$, $I_{Load} = 1-A - 20A$
TMOs power FET	MTB75N06HD	60V, 0.01 Ω

Body Controller Switching Unit Example

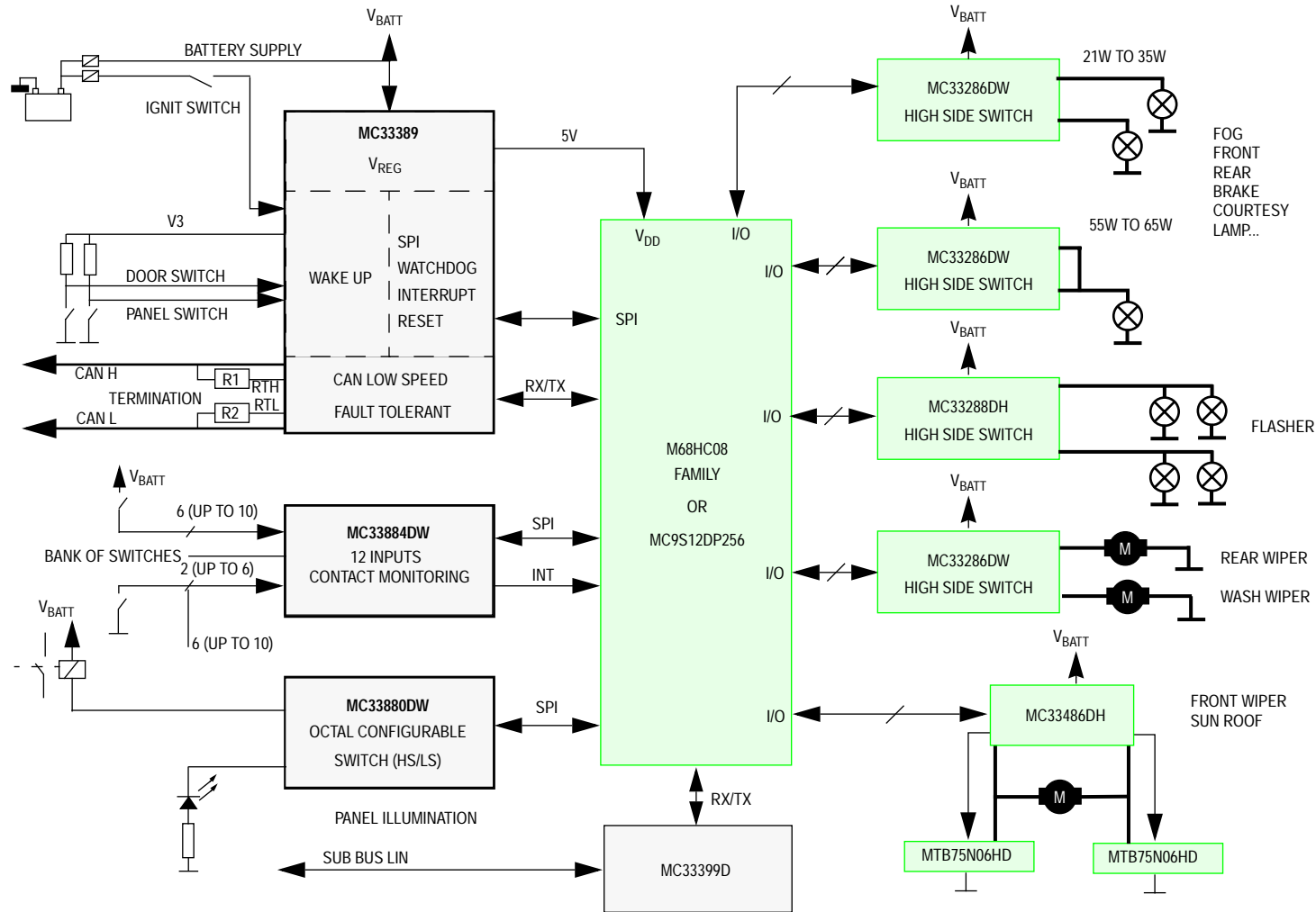

Device Application	Suggested Device	Device Highlights
System basis chip with CAN XSCVR, 2V-regulators, reset, IRQ	MC33889	SPI, CAN low-speed tolerant physical interface (125kbps)
Contact monitoring and dual low-side protected driver	MC33287DW	Parallel interface, $V_{BDSS} = 65V$, $R_{DS(on)} = 1.4\Omega$, $I_{LOAD} = 0.5A$
LIN physical interface	MC33399D	Supply 7V to 27V, several wakeup modes, sleep mode, slew rate 1 to 2V/ μs
Microcontroller	XC68HC908AZ60A	60K FLASH, 2K RAM, 1K EEPROM, CAN, 64 QFP(FU), 0.5 μ device
Motor driver/controller	MC33186DH1R2	150M Ω H-bridge driver, $V_{BDSS} = 40V$, $R_{DS(on)} = 0.15\Omega$
High-side driver	MC33486DH	Motor control with diagnostics and current recopy function, H-bridge, $V_{BDSS} = 40V$, $R_{SDON} = 15M\Omega$, $I_{Load} = 1-A - 20A$
TMOS power FET	MTB75N06HD	60V, 0.01 Ω
Microcontroller	MC9S12DP256	256K FLASH, 12K RAM, 4K EEPROM, timer, up to 5 CAN, 1 x J1850

RKE Transmitter/Receiver

RKE Transmitter/Receiver System Example

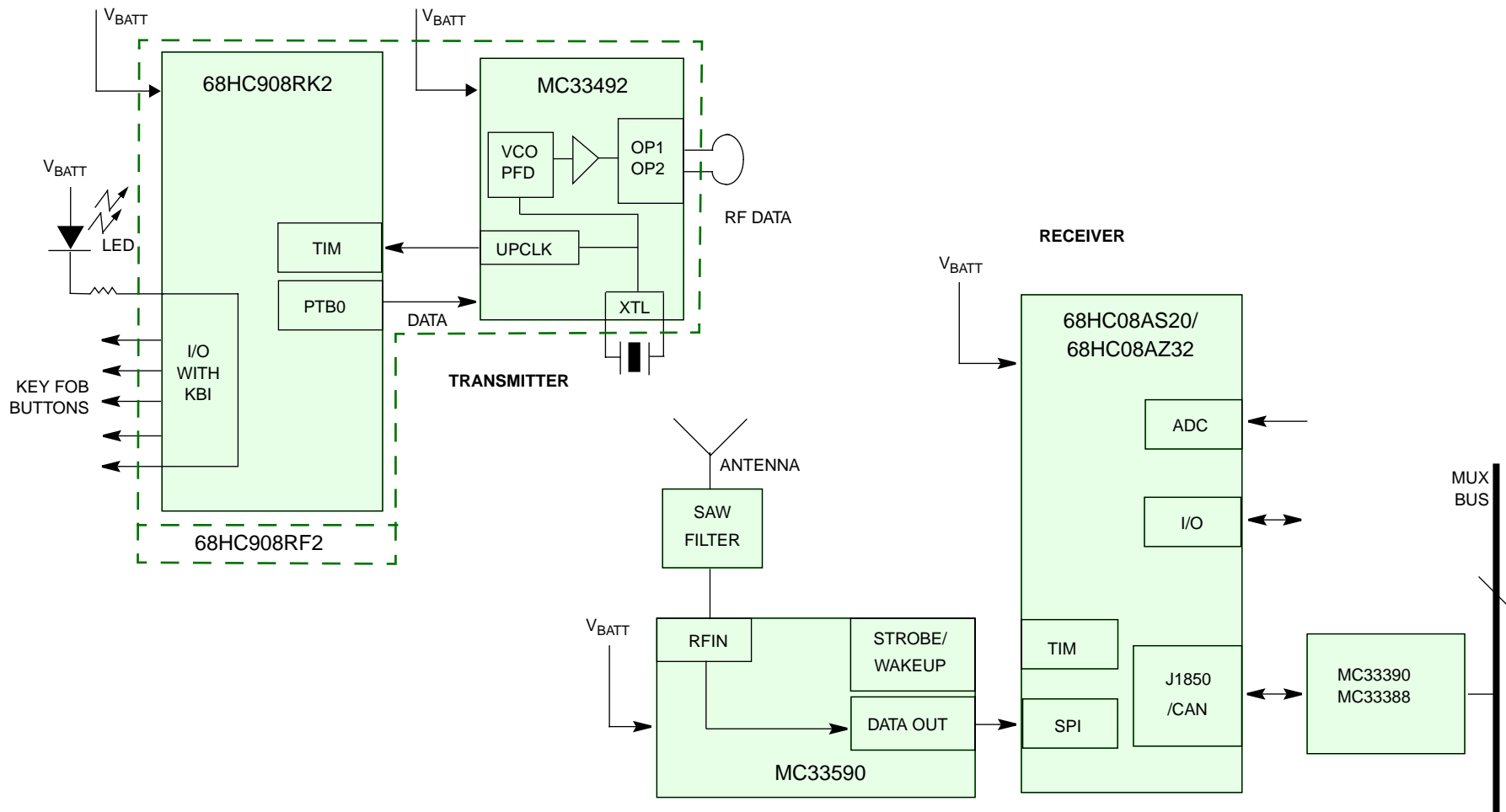

Device Application	Suggested Device	Device Highlights
Microcontroller	MC68HC908RK2	2K FLASH, 128K RAM, timer, low-power embedded FLASH routine
Microcontroller	XC68HC908RF2	2K FLASH, 128K RAM, timer, integrated RF transmitter
RF transmitter/receiver	MC33492	PLL tuned UHF transmitter (ASK and FSK modulation)
RF transmitter/receiver	MC33590	PLL tuned UHF AM receiver
Microcontroller	XC68HC08AS32	20K ROM, 1K RAM, 512 EEPROM, timer, A/D, SCI, SPI, J1850
J1850 serial link transceiver	MC33390	GM/Chrysler J1850 Class B
CAN physical interface	MC33388D	SPI, CAN low-speed tolerant physical interface (125kbps)

DSI Architecture Example

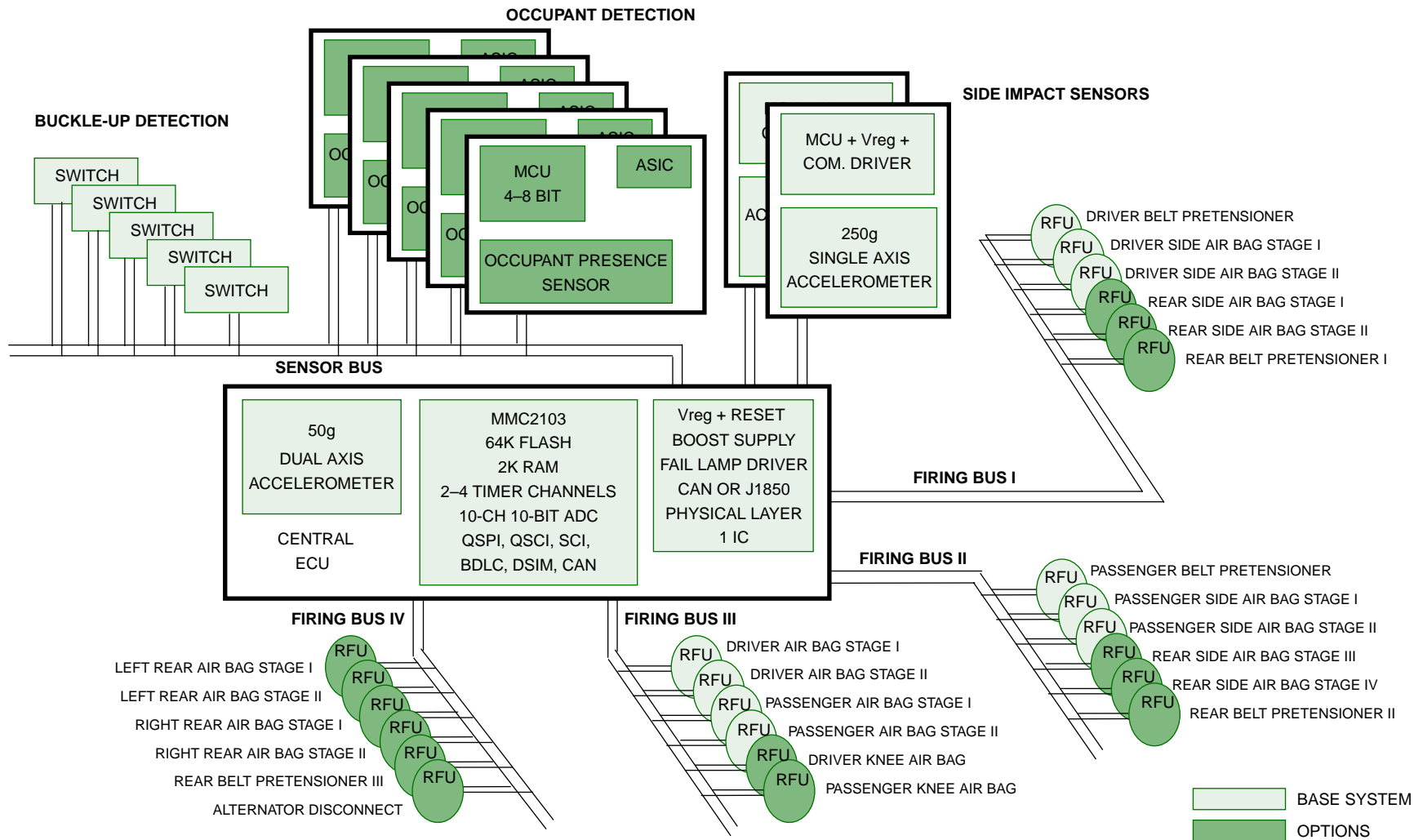

Device Application	Suggested Device	Device Highlights
DSI physical interface	MC33790	2-channel DSI physical interface for bus masters
M•CORE Microcontroller	MMC2103	With on-chip 8-channel DSI bus master protocol module
DSI Sensor	PC33793	Connects analog output sensors to the bus
DSI firing unit	PC33792	Connects remote squibs to the bus
Inertial sensor	50g	Dual axis, XY direction
Inertial sensor	250g	Single axis, Z direction

Single-Point Sensing

Motorola Single-Point Sensing Solution Example

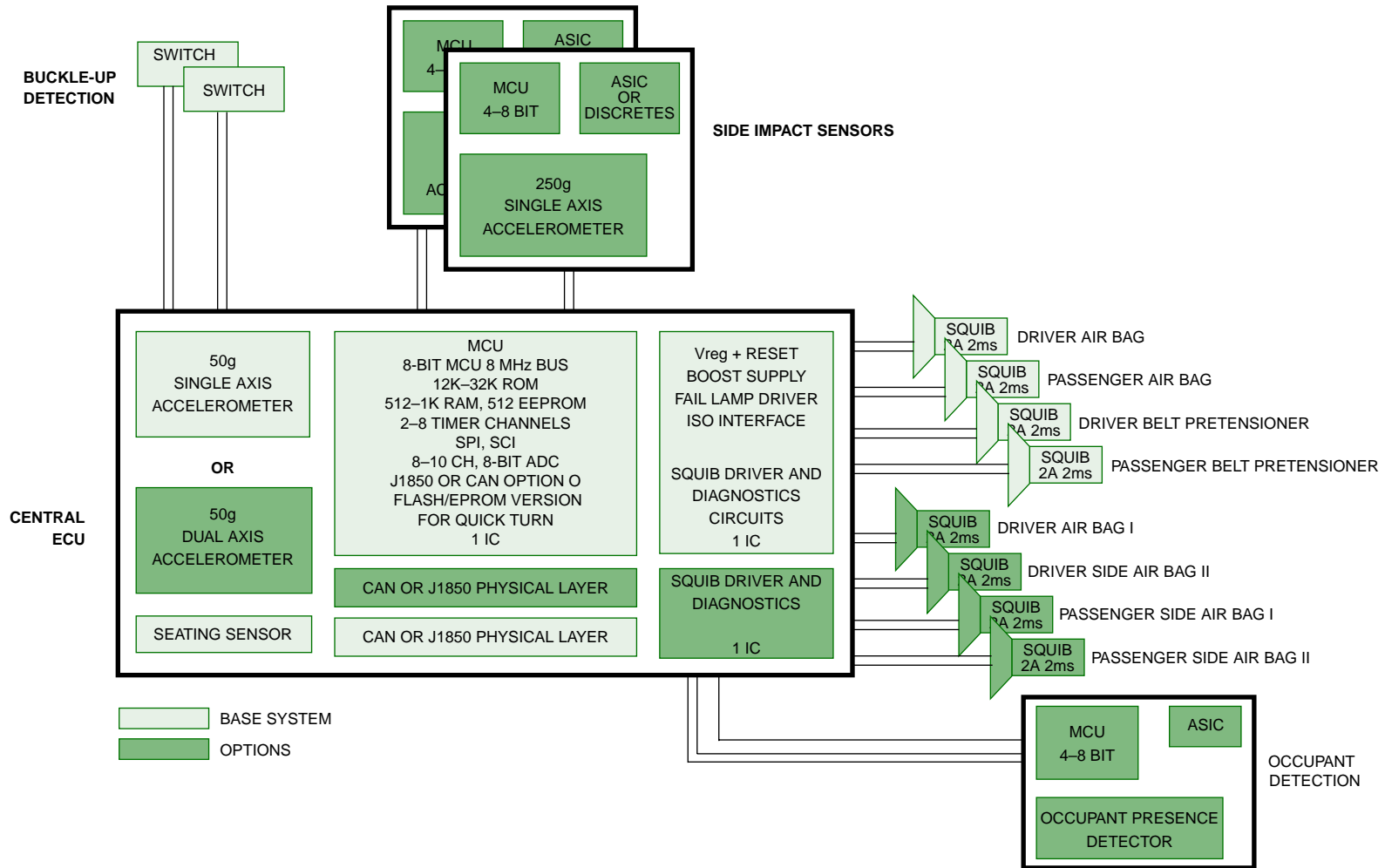

Device Application	Suggested Device	Device Highlights
Inertial sensor	50g	Dual axis, XY direction
Inertial sensor	50g	Single axis, X or Z direction
Inertial sensor	250g	Single axis, Z direction
Microcontroller	MC68HC05PV8A	8K ROM, 192 RAM, 128 EEPROM, timer, PWM, A/D
CAN physical interface	MC33388D	SPI, CAN, low-speed tolerant physical interface (125kbps)
Microcontroller	XC68HC912BC32	32K FLASH, 1K RAM, 768 EEPROM, timer, PWM, A/D, SCI, SPI, CAN
Microcontroller	PC68HC08AZ32A	32K ROM, 1K RAM, 512 EEPROM, timer, PWM, A/D, SCI, SPI, CAN

Adaptive Suspension

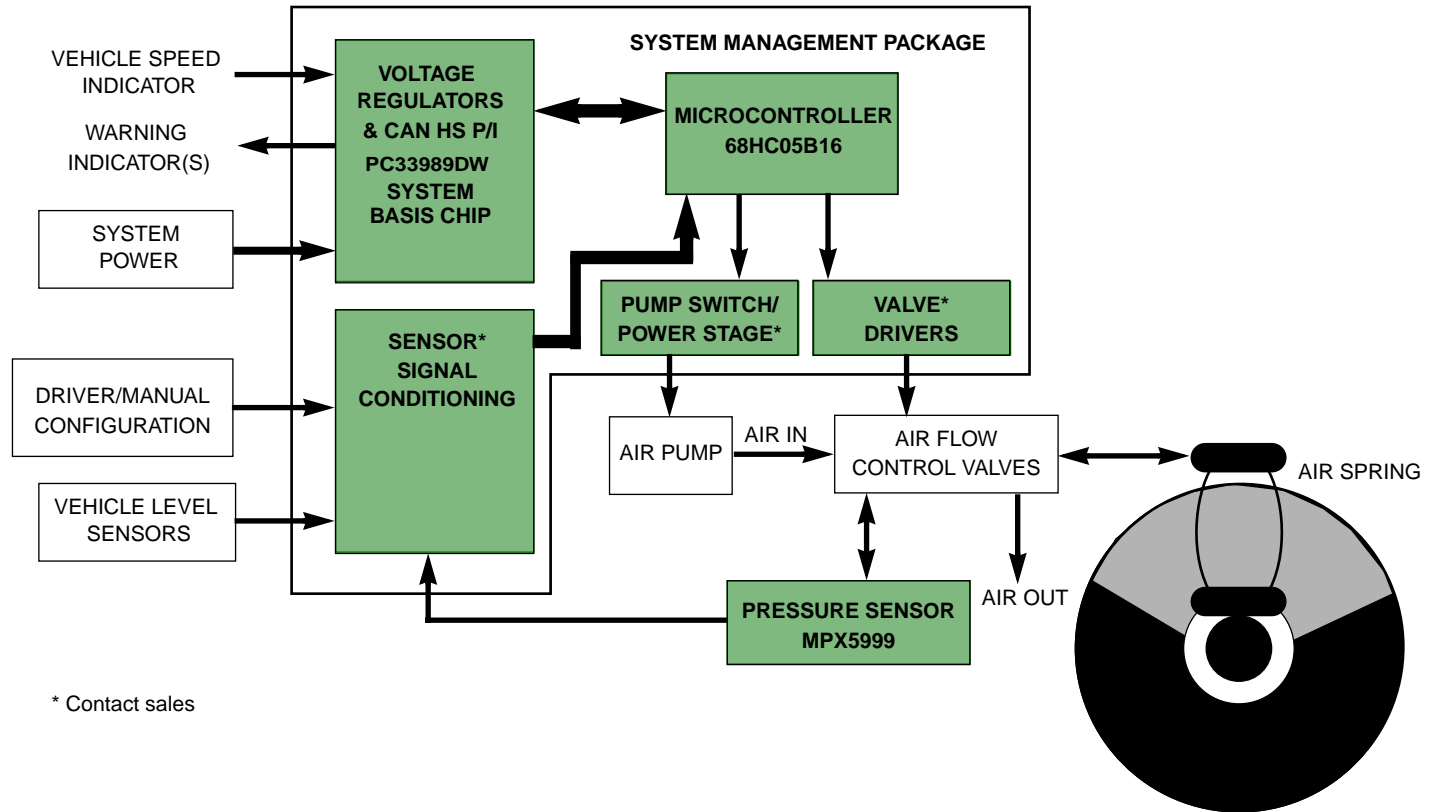

Device Application	Suggested Device	Device Highlights
Main MCU	68HC05B16	14.75K ROM, 352K RAM, 256K EEPROM, timer, SCI, A/D, PWM
Pressure sensor	MPX5999	1000KPa max. pressure rating, 4.5-mV/KPa sensitivity, 6-pin unibody package
System basis chip	PC33989	Cval Vreg+LS CAN+Wdg+3 WK up inputs, low speed, dual fault tolerant, 12V battery, 150μA, dual voltage regulator, watch dog, wake up input, sleep

Adaptive Suspension

Antilock Braking System

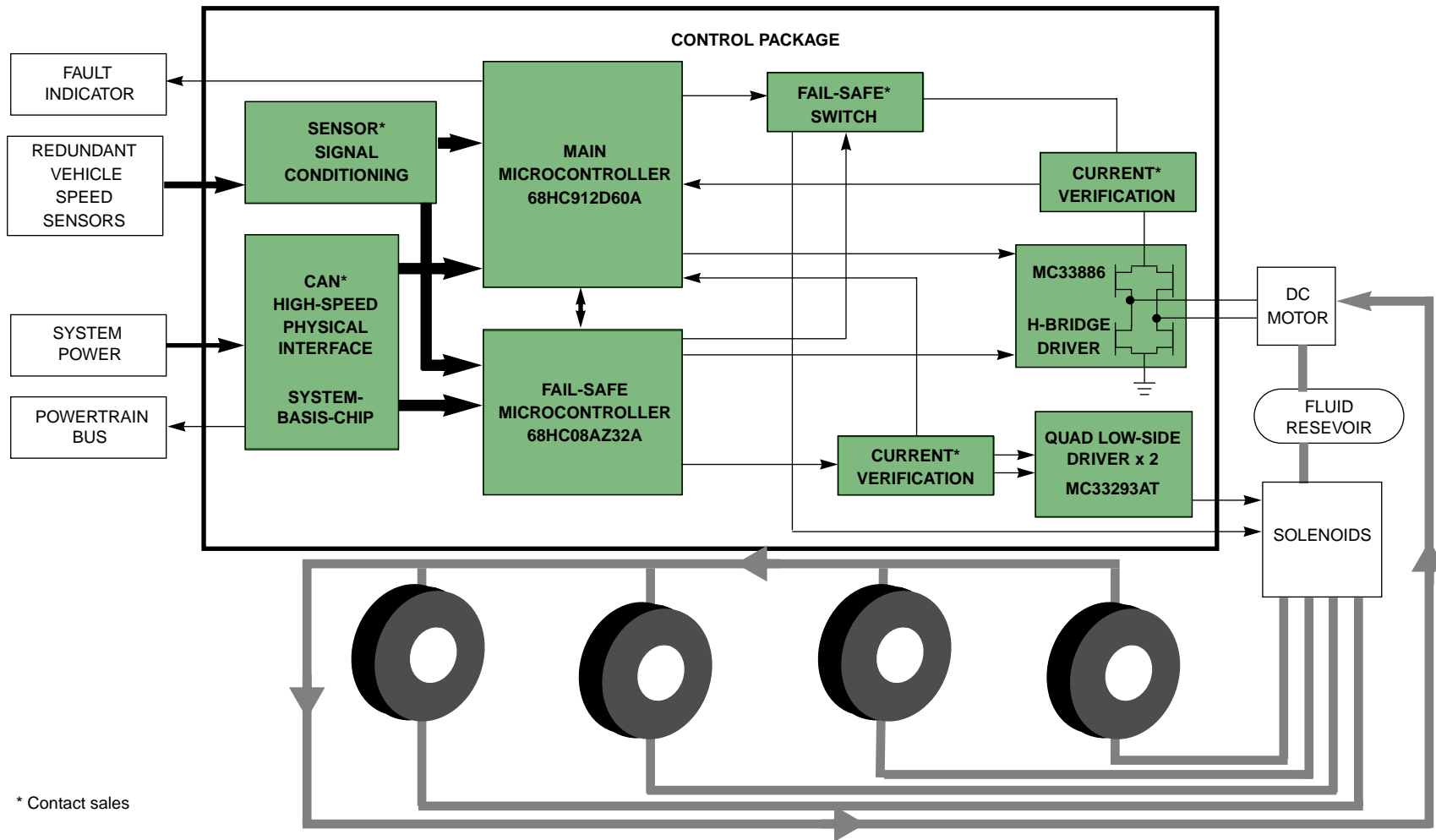

* Contact sales

Device Application	Suggested Device	Device Highlights
Main MCU	PC68HC912D60A	2K RAM, 60K FLASH, 8-CH/16-bit ECT, 2 SCI, SPI, CAN 2.0a/b
H-bridge driver	MC33886	150-mΩ H-bridge driver
Low-side driver	MC33293AT	Dual low-side driver
Fail-safe MCU	PC68HC08AZ32A	32K ROM, 1K RAM, 512 bytes EEPROM, CAN 2.0a/b, 64 QFP packaging option

Electric Power Assist Steering System Example

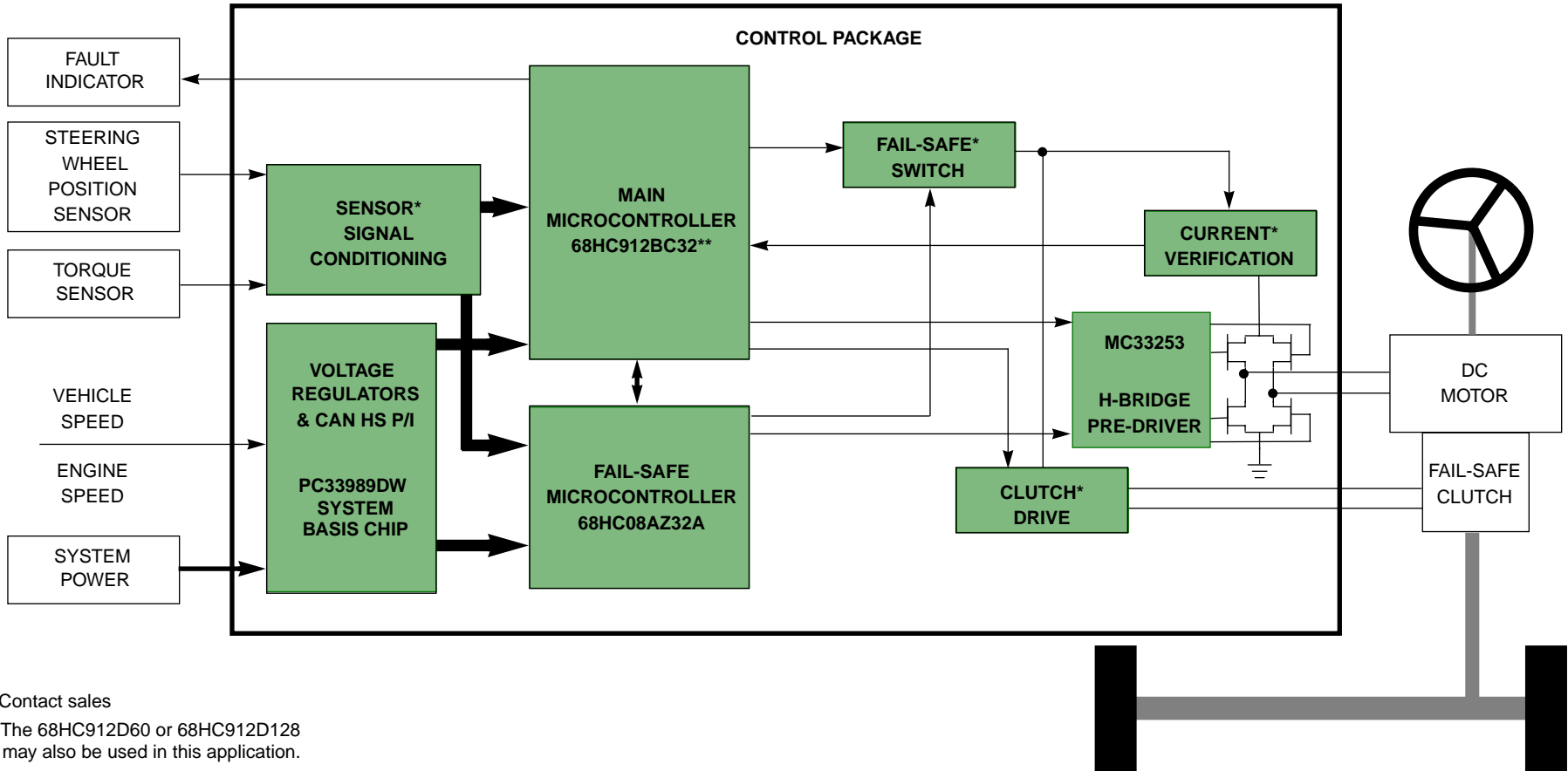

* Contact sales

** The 68HC912D60 or 68HC912D128 may also be used in this application.

Device Application	Suggested Device	Device Highlights
Main MCU	XC68HC912BC32	32K ROM, 1K RAM, 768 bytes EEPROM, CAN 2.0a/b, 80 QFP packaging option
Fail-safe MCU	PC68HC08AZ32A	32K ROM, 1K RAM, 512 bytes EEPROM, CAN 2.0a/b, 64 QFP packaging option
H-bridge driver	MC33253	Full bridge pre-driver, 1A pulse current, global enable, SO20 packaging

TPMS

Tire Pressure Monitoring System (TPMS) Enabling Chip Set

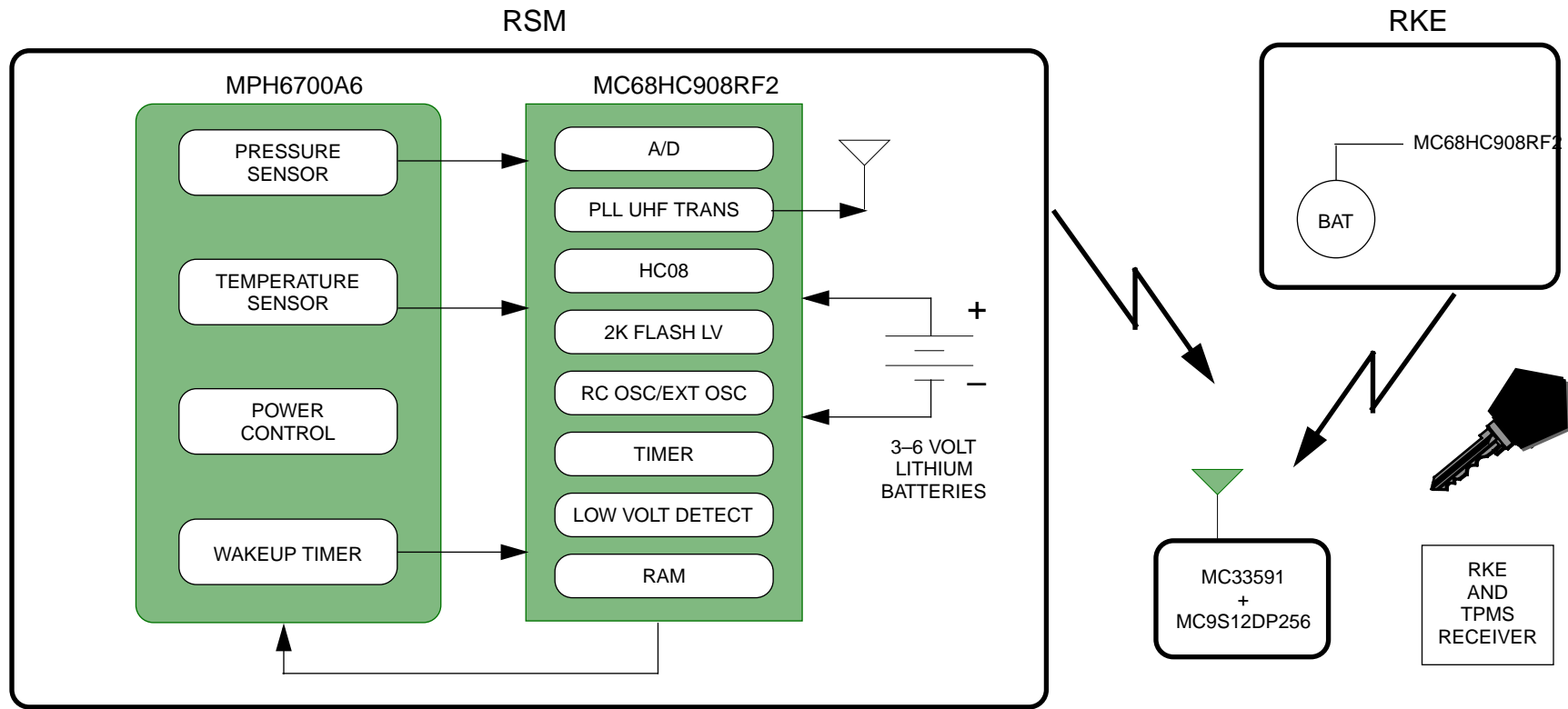

Device Application	Suggested Device	Device Highlights
Pressure sensor	MPH6700A6	Surface micromachined CMOS technology, power control, battery voltage detection, and wakeup, SSOP package
UHF receiver	MC33591	PLL tuned UHF AM receiver
UHF transmitter + MCU (FLASH)	MC68HC908RF2	2K user FLASH ROM, 128 RAM, timer, integrated RF transmitter
Receiver Microcontroller	MC9S12DP256	256K FLASH, 12K RAM, 4K EEPROM, up to 5 CAN, 1xJ1850, 250MHz operating speed.

Direct Injection System Example

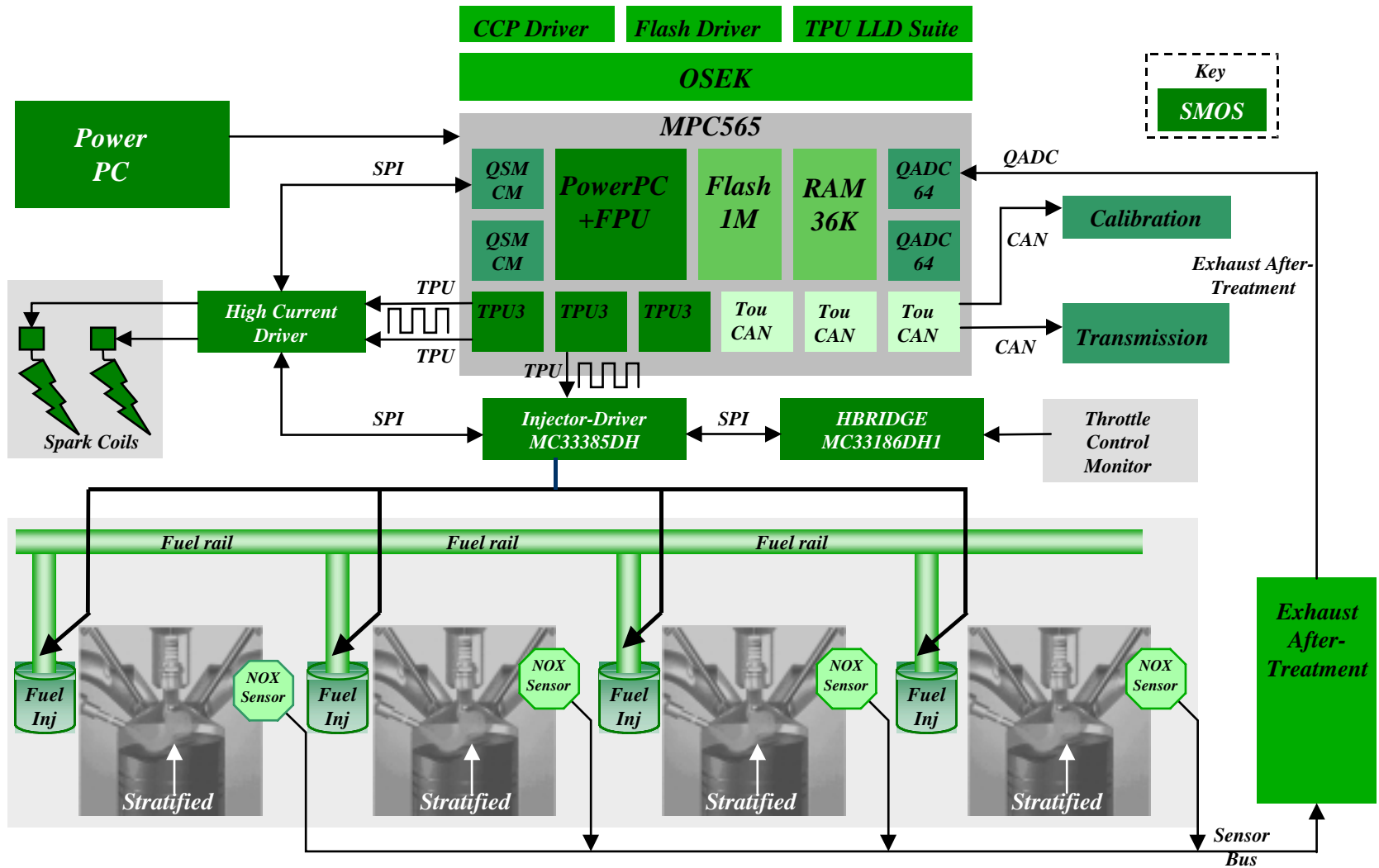

Device	Suggested Device	Device Highlights
PowerPC microcontroller	MPC565	1M FLASH, 36K RAM + 10K for TPU + 4K DECRAM
H-bridge driver	MC33186DH1	150-mΩ H-bridge driver
Direct injection FET driver	MC33385DH	Direct fuel injection MOSFET driver and controller

Direct Injection System

Driver Information

Driver Information Systems, mobileGT™ Architecture

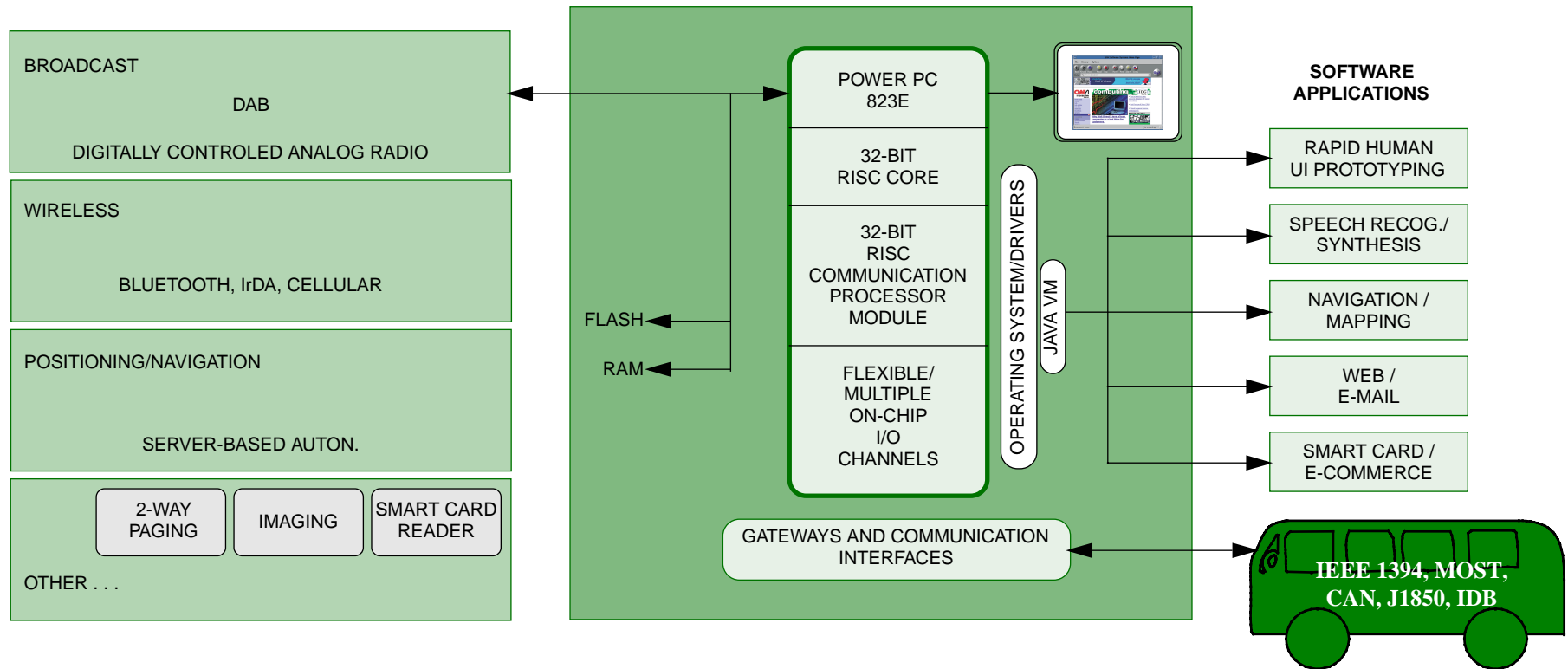

Device	Processor Speed (Typ)	Drystone Performance (MIPS)	Microprogrammable Module	Translation Lookaside Buffers	FPU Floating Point Unit	Parallel (Bits)	Power Dissipation (Typ)	Miscellaneous Peripherals	Cache-L1 Instructional	Cache-L1 Data
MPC823E	81 MHz	105 + 80 MHz	CPM	8-entry	—	53	170 m @ 25 MHz	2 UARTs, 1 IC, 1 SPI, USB	16 KBytes	8 KBytes

— Definitions —

ADC — Analog-to-Digital Converter
BDM — Background Debug Mode
CAN — Controller Area Network
CDIP — Ceramic Dual In-Line Package
CLCC — Ceramic Leaded Chip Carrier
COP — Computer Operating Properly (Watchdog Timer)
CPU16 — 16-Bit Central Processor Unit (HC11 Compatible)
CPU32 — 32-Bit Central Processor Unit (68000 Compatible)
CTM — Configurable Timer Module (Various Hardware Options)
DIP — Dual In-line Package
DTMF — Dual-Tone Multi-Frequency
EBI — External Bus Interface
GPT — General-Purpose Timer Module (4 IC, 5 OC, 2 PWM)
IC — Input Capture
I²C — Inter-Integrated Circuit
i/o — Bidirectional Input and Output Port Pins
i — Input-Only Port Pins
ISPI — Interval Serial Peripheral Interface
KBI — Keyboard Interrupt
LCD — Liquid Crystal Display
LTD — Limited Availability
LQFP — Low-Profile Quad Flat Pack
LVI — Low-Voltage Interrupt
LVR — Low-Voltage Reset
MC — Fully Qualified Production
MCCI — Multi-Channel Communication Interface (2 SCI, SPI)
MFT — Multi-Function Timer
MUX — Multiplexed
o — Output-Only Port Pins
OC — Output Compare
PC — Pre-Qualification, Engineering Samples Only
PEEP — Personality EEPROM
PEP — Personality EPROM
PLCC — Plastic Leaded Chip Carrier
PLL — Phase-Locked Loop
PQFP — Plastic Quad Flat Pack
PWM — Pulse-Width Modulation

QADC — Queued Analog-to-Digital Converter (10-Bit)
QFP — Quad Flat Pack
QSM — Queued Serial Module (SCI + QSPI)
QSPI — Queued SPI
RTI — Real-Time Interrupt
SCI — Serial Communication Interface
SCI+ — Enhanced SCI
SCIM — Single-Chip Integration Module
SDIP — Shrink Dual In-line Package
SIM — System Integration Module
SIML — Low-Power System Integration Module
SIOP — Simple Serial I/O Port
SPI — Serial Peripheral Interface
SPI+ — Enhanced SPI
SRAM — Standby RAM Module
TPU — Time Processor Unit (16 Programmable Channels)
TPURAM — Standby RAM Module with TPU Emulation Capability
UART — Universal Asynchronous Receiver/Transmitter
USB — Universal Serial Bus
XC — Initial Production Qualification, Not Fully Characterized

— Package Designators —

B — Shrink DIP (70 mil spacing)
DW — Small Outline (Wide-Body SOIC)
FA — 7 x 7 mm Quad Flat Pack (QFP)
FB — 10 x 10 mm Quad Flat Pack (QFP)
FE — CQFP (windowed) — Samples Only
FN — Plastic Quad (PLCC)
FS — CLCC (windowed) — Samples Only
FT — 28 x 28 mm Quad Flat Pack (QFP)
FU — 14 x 14 mm Quad Flat Pack (QFP)
FZ — CQFP (windowed) — Samples Only
K — Cerdip (windowed) — Samples Only
L — Ceramic Sidebrazed
P — Dual in-Line Plastic
PU — 14 x 14 mm Low-Profile Quad Flat Pack (LQFP)
PV — 20 x 20 mm Low-Profile Quad Flat Pack (LQFP)
S — Cerdip (windowed) — Samples Only
TM — Mechatronics Connector

Device Numbering System for Microcontrollers

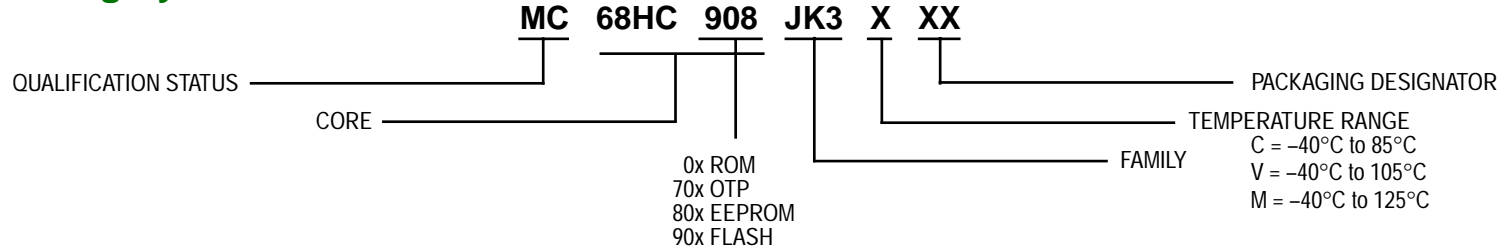

Device Numbering System for Pressure Sensors

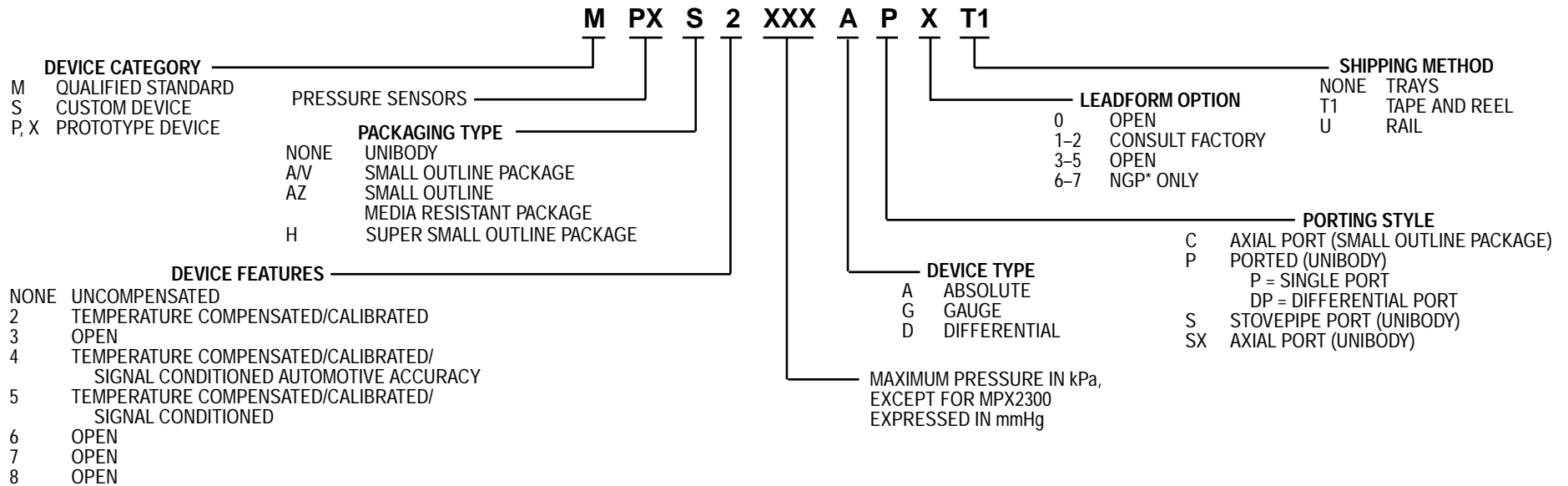

Device Numbering System for MPC5xx

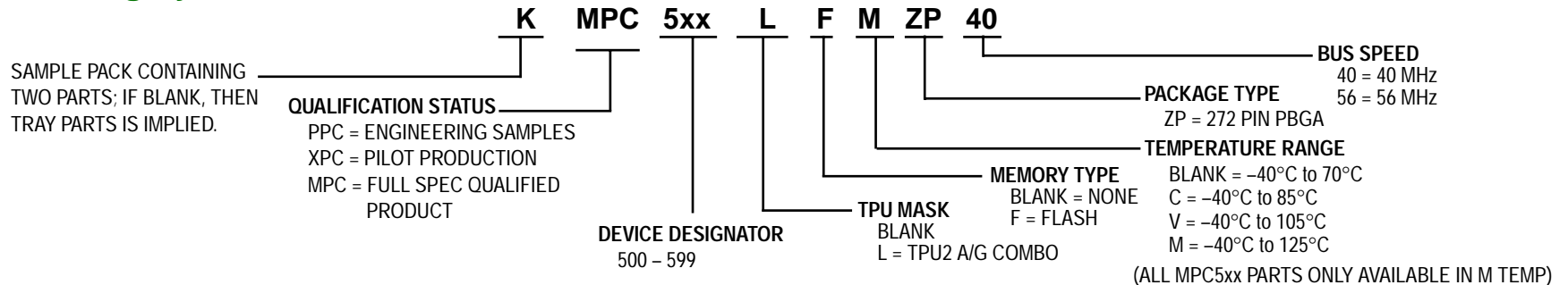

84-Lead PLCC/CLCC

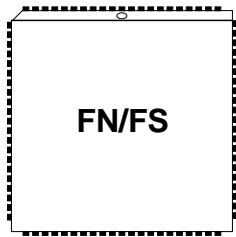

50 mil/1.27 mm Pitch
1.15 in x 1.15 in Body

68-Lead PLCC/CLCC

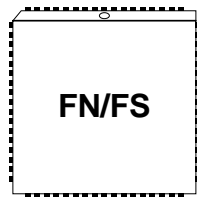

50 mil/1.27 mm Pitch
0.950 in x 0.950 in Body

52-Lead PLCC/CLCC

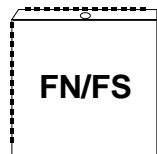

50 mil/1.27 mm Pitch
0.750 in x 0.750 in Body

44-Lead PLCC/CLCC

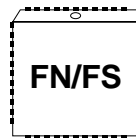

50 mil/1.27 mm Pitch
0.650 in x 0.650 in Body

28-Lead SOIC



50 mil/1.27 mm Pitch
18.0 mm x 7.5 mm Body

20-Lead SOIC

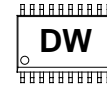

50 mil/1.27 mm Pitch
12.8 mm x 7.5 mm Body

16-Lead SOIC



50 mil/1.27 mm Pitch
10.35 mm x 7.5 mm Body

160-Lead QFP

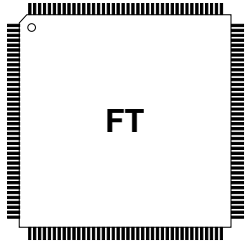

.65 mm Pitch
28 mm x 28 mm Body

144-Lead LQFP

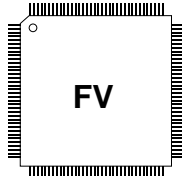

.5 mm Pitch
20 mm x 20 mm Body

132-Lead PQFP

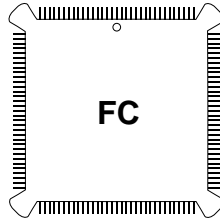

25 mil/06.35 mm Pitch
0.950 in x 0.950 in Body
(Nominal, w.o. Bumpers)

112-Lead LQFP

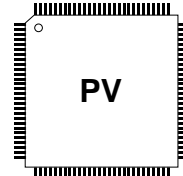

.65 mm Pitch
20 mm x 20 mm Body

100-Lead LQFP

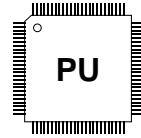

.5 mm Pitch
14 mm x 14 mm Body

80-Lead QFP/LQFP

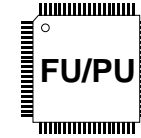

.65 mm Pitch
14 mm x 14 mm Body

64-Lead QFP

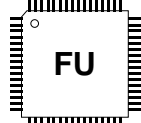

.8 mm Pitch
14 mm x 14 mm Body

52-Lead QFP

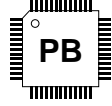

.65 mm Pitch
10 mm x 10 mm Body

44-Lead QFP

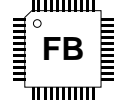

.8 mm Pitch
10 mm x 10 mm Body

32-Lead QFP



.8 mm Pitch
7 mm x 7 mm Body

388-Ball PBGA

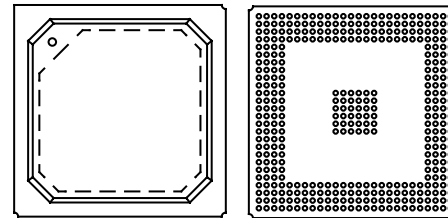

1 mm Pitch
27.0 mm x 27.0 mm Body

272-Ball PBGA

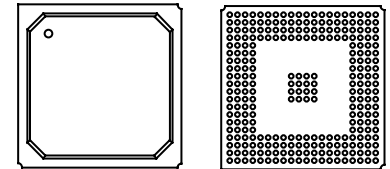

1.27 mm Pitch
27.0 mm x 27.0 mm Body

56-Pin Plastic SDIP

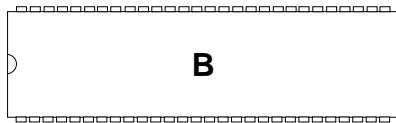

70 mil/1.778 mm Pitch
2.05 in x .55 in Body
(70 mil x 600 mil pin centers)

42-Pin Plastic SDIP

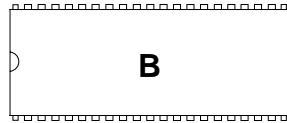

70 mil/1.778 mm Pitch
1.45 in x .55 in Body
(70 mil x 600 mil pin centers)

48-Pin Plastic DIP

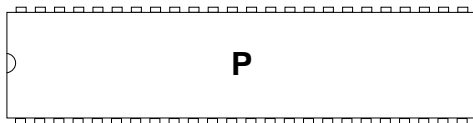

100 mil/2.54 mm Pitch
2.45 in x .55 in Body
(100 mil x 600 mil pin centers)

40-Pin Plastic DIP

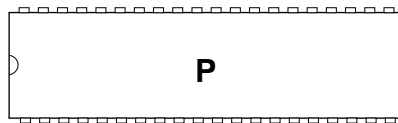

100 mil/2.54 mm Pitch
2.05 in x .55 in Body
(100 mil x 600 mil pin centers)

28-Pin DIP

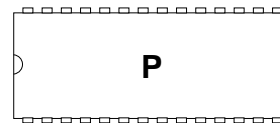

100 mil/2.54 mm Pitch
1.45 in x .55 in Body
(100 mil x 600 mil pin centers)

20-Pin Plastic DIP



100 mil/2.54 mm Pitch
.97 in x .29 in Body
(100 mil x 600 mil pin centers)

16-Pin Plastic DIP

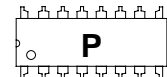

100 mil/2.54 mm Pitch
.75 in x .25 in Body
(100 mil x 600 mil pin centers)

Package Options

Package Options

4-Pin

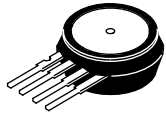

BASIC ELEMENT
CASE 344-15
SUFFIX A/D



GAUGE PORT
CASE 344B-01
SUFFIX AP/GP

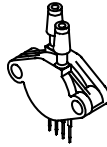

DUAL PORT
CASE 344C-01
SUFFIX DP

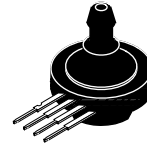

STOVEPIPE PORT
CASE 344E-01
SUFFIX AS/GS

6-Pin

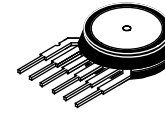

BASIC ELEMENT
CASE 867-08
SUFFIX A/D

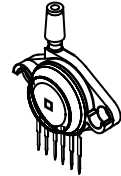

GAUGE PORT
CASE 867B-04
SUFFIX AP/GP

8-Pin

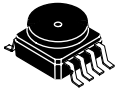

SUPER SMALL OUTLINE
(SURFACE MOUNT)
CASE 1317-02

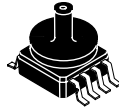

SUPER SMALL OUTLINE
(SURFACE MOUNT/PORTED)
CASE 1317A-02

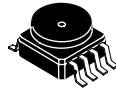

SMALL OUTLINE
(SURFACE MOUNT)
CASE 482-01

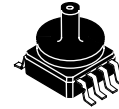

SMALL OUTLINE
(SURFACE MOUNT/PORTED)
CASE 482A-01

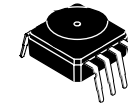

SMALL OUTLINE
(DIP)
CASE 482B-03

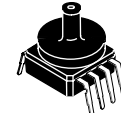

SMALL OUTLINE
(PORTED/DIP)
CASE 482C-03

Motorola reserves the right to make changes without further notice to any products herein. Motorola makes no warranty, representation or guarantee regarding the suitability of its products for any particular purpose, nor does Motorola assume any liability arising out of the application or use of any product or circuit, and specifically disclaims any and all liability, including without limitation consequential or incidental damages. "Typical" parameters which may be provided in Motorola data sheets and/or specifications can and do vary in different applications and actual performance may vary over time. All operating parameters, including "Typicals" must be validated for each customer application by customer's technical experts. Motorola does not convey any license under its patent rights nor the rights of others. Motorola products are not designed, intended, or authorized for use as components in systems intended for surgical implant into the body, or other applications intended to support or sustain life, or for any other application in which the failure of the Motorola product could create a situation where personal injury or death may occur. Should Buyer purchase or use Motorola products for any such unintended or unauthorized application, Buyer shall indemnify and hold Motorola and its officers, employees, subsidiaries, affiliates, and distributors harmless against all claims, costs, damages, and expenses, and reasonable attorney fees arising out of, directly or indirectly, any claim of personal injury or death associated with such unintended or unauthorized use, even if such claim alleges that Motorola was negligent regarding the design or manufacture of the part. Motorola and  are registered trademarks of Motorola, Inc. Motorola, Inc. is an Equal Opportunity/Affirmative Action Employer.

How to reach us:

USA/EUROPE/Locations Not Listed: Motorola Literature Distribution, P.O. Box 5405, Denver, Colorado 80217. 1-303-675-2140 or 1-800-441-2447. Customer Focus Center, 1-800-521-6274

JAPAN: Motorola Japan Ltd.; SPS, Technical Information Center, 3-20-1, Minami-Azabu, Minato-ku, Tokyo 106-8573 Japan. 81-3-3440-8573

ASIA/PACIFIC: Motorola Semiconductors H.K. Ltd.; Silicon Harbour Centre, 2 Dai King Street, Tai Po Industrial Estate, Tai Po, N.T., Hong Kong. 852-26668334

HOME PAGE: <http://motorola.com/semiconductors/>



MOTOROLA

© Motorola, Inc., 2001

SG187/D