

## FEATURES

- Fully ISO 7816-3 and EMV Compliant
- Buck-Boost Charge Pump Generates 3V or 5V
- 2.7V to 5.5V Input Voltage Range
- 3V↔ 5V Signal Level Translator
- >10kV ESD on All Smart Card Pins
- Dynamic Pull-Ups Deliver Fast Signal Rise Times
- Soft Start Limits Inrush Current at Turn On
- Very Low Operating Current: 75µA
- Shutdown Current: <2.5µA
- Short-Circuit and Overtemperature Protected
- Available in 16-Pin SSOP Package

## APPLICATIONS

- Handheld Payment Terminals
- Pay Telephones
- ATMs
- Key Chain Readers
- Smart Card Readers

## DESCRIPTION

The LTC<sup>®</sup>1756 universal Smart Card interface is fully compliant with ISO 7816-3 and EMV specifications. It provides the smallest and simplest interface circuit between a host microcontroller and general purpose Smart Cards.

An internal charge pump DC/DC converter delivers regulated 3V or 5V to the Smart Card, while an on-chip level shifter allows a connection to a low voltage controller. All Smart Card contacts are rated for 10kV ESD, eliminating the need for external ESD protection devices.

Input voltage may range from 2.7V to 5.5V, allowing direct connection to a battery. Automatic DC/DC converter soft start mitigates start-up problems that may result when the input power is provided by another regulator.

Battery life is maximized by 75µA operating current and 2µA shutdown current. The 16-pin SSOP package minimizes PCB area for compact portable systems.

**LT**, LTC and LT are registered trademarks of Linear Technology Corporation.

## TYPICAL APPLICATION

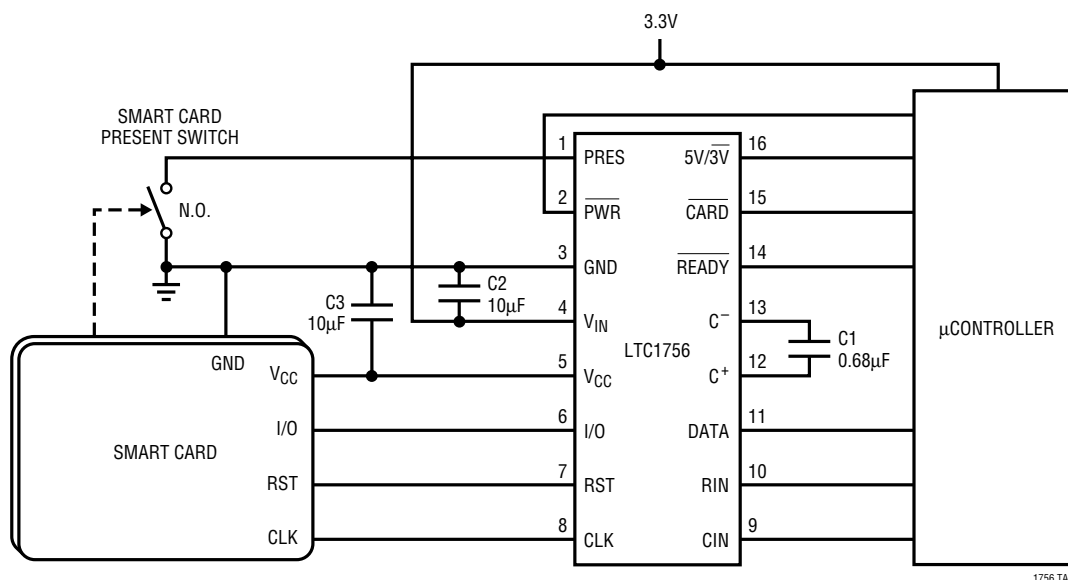

1756 TA01

## ABSOLUTE MAXIMUM RATINGS

(Note 1)

$V_{IN}$ to GND .....	-0.3V to 6.0V
$V_{CC}$ to GND .....	-0.3V to 5.5V
Digital Inputs to GND .....	-0.3V to $V_{IN} + 0.3V$
CLK, RST, I/O to GND .....	-0.3V to $V_{CC} + 0.3V$
$V_{CC}$ Short-Circuit Duration .....	Indefinite
Operating Temperature Range (Note 2) ..	-40°C to 85°C
Storage Temperature Range .....	-65°C to 150°C
Lead Temperature (Soldering, 10 sec).....	300°C

## PACKAGE/ORDER INFORMATION

<p>TOP VIEW</p> <p>GN PACKAGE 16-LEAD NARROW PLASTIC SSOP</p> <p><math>T_{JMAX} = 125^{\circ}C</math>, <math>\theta_{JA} = 135^{\circ}C/W</math></p>	<p>ORDER PART NUMBER</p> <p>LTC1756EGN</p>
--	--

Consult factory for Industrial and Military grade parts.

## ELECTRICAL CHARACTERISTICS

The ● denotes specifications which apply over the full specified temperature range, otherwise specifications are at  $T_A = 25^{\circ}C$ .  $V_{IN} = 2.7V$  to  $5.5V$ , unless otherwise noted.

PARAMETER	CONDITIONS	MIN	TYP	MAX	UNITS
<b>Power Supply</b>					
$V_{IN}$ Operating Voltage		● 2.7		5.5	V
$I_{VIN}$ Operating Current	ACTIVE State, $I_{VCC} = 0$	●	75	150	$\mu A$
$I_{VIN}$ Shutdown Current	IDLE State, $V_{IN} \leq 3.6V$	●		2.5	$\mu A$
	IDLE State, $3.6V \leq V_{IN} \leq 5.5V$	●		10	$\mu A$
$V_{CC}$ Output Voltage	$5V/\overline{3V} = V_{IN}$	● 4.75	5.00	5.25	V
	$5V/\overline{3V} = 0V$	● 2.80	3.00	3.20	V
$I_{VCC}$ Output Current	$5V/\overline{3V} = 0V$ $3V \leq V_{IN} \leq 5.5V$	● 55			mA
	$5V/\overline{3V} = V_{IN}$ $3V \leq V_{IN} \leq 5.5V$	● 65			mA
	$5V/\overline{3V} = 0V$ $2.7V \leq V_{IN} \leq 5.5V$	● 55			mA
	$5V/\overline{3V} = V_{IN}$ $2.7V \leq V_{IN} \leq 5.5V$	● 40			mA
$V_{CC}$ Turn-On Time	$C_{OUT} = 10\mu F$ , $\overline{V}_{PWR}$ to $\overline{V}_{READY}$	●	2.7	12	ms
$V_{CC}$ Discharge Time to 0.4V	$I_{VCC} = 0mA$ , $V_{CC} = 5V$ , $C_{OUT} = 10\mu F$	●	100	250	$\mu s$
<b>Controller Input/Output DATA</b>					
High Input Voltage Threshold ( $V_{IH}$ )		● $V_{IN} - 0.6$	$0.5 \cdot V_{IN}$		V
Low Input Voltage Threshold ( $V_{IL}$ )		●	$0.5 \cdot V_{IN}$	0.3	V
High Level Output Voltage ( $V_{OH}$ )	Source Current = $20\mu A$	● $0.7 \cdot V_{IN}$			V
Low Level Output Voltage ( $V_{OL}$ )	Sink Current = $-500\mu A$ (Note 3)	●		0.3	V
Output Rise/Fall Time	Loaded with $30pF$ , 10% to 90%	●		0.5	$\mu s$
Input Current ( $I_{IH}/I_{IL}$ )	$\overline{PWR} = V_{IN}$	● -1		1	$\mu A$

## ELECTRICAL CHARACTERISTICS

The ● denotes specifications which apply over the full specified temperature range, otherwise specifications are at  $T_A = 25^\circ\text{C}$ .  $V_{IN} = 2.7\text{V}$  to  $5.5\text{V}$ , unless otherwise noted.

PARAMETER	CONDITIONS		MIN	TYP	MAX	UNITS
<b>RIN, CIN, PWR, 5V/3V</b>						
High Input Voltage Threshold ( $V_{IH}$ )		●	$0.7 \cdot V_{IN}$	$0.5 \cdot V_{IN}$		V
Low Input Voltage Threshold ( $V_{IL}$ )		●		$0.5 \cdot V_{IN}$	$0.2 \cdot V_{IN}$	V
Input Current ( $I_{IH}/I_{IL}$ )		●	-1		1	$\mu\text{A}$
<b>READY, CARD</b>						
Pull-Up Current ( $I_{OH}$ )		●	250			nA
Low Level Output Voltage ( $V_{OL}$ )	Sink Current = $-20\mu\text{A}$	●			0.3	V
<b>Smart Card Input/Output I/O, <math>V_{CC} = 3\text{V}</math> or <math>5\text{V}</math></b>						
High Input Voltage Threshold ( $V_{IH}$ )	$I_{IH(\text{MAX})} = \pm 20\mu\text{A}$	●	$0.6 \cdot V_{CC}$	$0.5 \cdot V_{CC}$		V
Low Input Voltage Threshold ( $V_{IL}$ )	$I_{IL(\text{MAX})} = 1\text{mA}$	●		$0.5 \cdot V_{CC}$	0.8	V
High Level Output Voltage ( $V_{OH}$ )	Source Current = $20\mu\text{A}$ , DATA = $V_{IN}$	●	$0.8 \cdot V_{CC}$			V
Low Level Output Voltage ( $V_{OL}$ )	Sink Current = $-1\text{mA}$ , DATA = $0\text{V}$ (Note 3)	●			0.3	V
Rise/ Fall Time	Loaded with $30\text{pF}$ , 10% to 90%	●			0.5	$\mu\text{s}$
Short-Circuit Current	Shorted to $V_{CC}$	●		3.5	5	mA
<b>CLK</b>						
High Level Output Voltage ( $V_{OH}$ )	Source Current = $100\mu\text{A}$	●	$V_{CC} - 0.5$			V
Low Level Output Voltage ( $V_{OL}$ )	Sink Current = $-200\mu\text{A}$	●			0.3	V
CLK Rise/Fall Time	CLK Loaded with $30\text{pF}$	●			16	ns
CLK Frequency	CLK Loaded with $30\text{pF}$	●	5			MHz
<b>RST</b>						
High Level Output Voltage ( $V_{OH}$ )	Source Current = $200\mu\text{A}$	●	$0.8 \cdot V_{CC}$			V
Low Level Output Voltage ( $V_{OL}$ )	Sink Current = $-200\mu\text{A}$	●			0.3	V
RST Rise/Fall Time	Loaded with $30\text{pF}$	●			0.5	$\mu\text{s}$
<b>PRES</b>						
High Input Voltage Threshold ( $V_{IH}$ )		●	$0.7 \cdot V_{IN}$	$0.5 \cdot V_{IN}$		V
Low Input Voltage Threshold ( $V_{IL}$ )		●		$0.5 \cdot V_{IN}$	$0.2 \cdot V_{IN}$	V
PRES Pull-Up Current	$V_{PRES} = 0\text{V}$	●	0.5	1		$\mu\text{A}$
PRES Debounce Time	Proportional to the $0.68\mu\text{F}$ Charge Pump Capacitor	●	40	80		ms

**Note 1:** Absolute Maximum Ratings are those values beyond which the life of a device may be impaired.

**Note 2:** The LTC1756 is guaranteed to meet performance specifications from  $0^\circ\text{C}$  to  $70^\circ\text{C}$ . Specifications over the  $-40^\circ\text{C}$  to  $85^\circ\text{C}$  operating temperature range are assured by design, characterization and correlation with statistical process controls.

**Note 3:** The DATA and I/O pull-down drivers must sink up to  $250\mu\text{A}$  sourced by the internal current sources.

## PIN FUNCTIONS

**PRES (Pin 1):** (Input) Connects to the Smart Card acceptor's PRESENT indicator switch to detect if a card is inserted. This pin has a pull-up current source so that a normally open grounded switch can be detected with no external components. The pull-up current source is nonlinear, delivering higher current when the PRES pin is above 1V but very little current below 1V. This helps resist false card indications due to leakage current.

**PWR (Pin 2):** (Input) A low on the PWR pin places the LTC1756 in the ACTIVE state enabling the charge pump. The  $\overline{\text{READY}}$  pin indicates when the card supply voltage ( $V_{\text{CC}}$ ) has reached its final value and communication with the Smart Card is possible. The reset and clock channels are enabled after  $\overline{\text{READY}}$  goes low. The I/O channel is also enabled only after  $\overline{\text{READY}}$  goes low.

The falling edge of  $\overline{\text{PWR}}$  latches the state of the 5V/3V pin. After PWR is low, changes on the 5V/3V pin are ignored.

**GND (Pin 3):** Ground Reference for the IC. This pin should be connected to a low impedance ground plane. Bypass capacitors for  $V_{\text{IN}}$  and  $V_{\text{CC}}$  should be in close proximity to the GND pin.

**$V_{\text{IN}}$  (Pin 4):** Supply Voltage. May be between 2.7V and 5.5V. A 10 $\mu\text{F}$  low ESR ceramic bypass capacitor is required on this pin for optimum performance.

**$V_{\text{CC}}$  (Pin 5):** Regulated Smart Card Supply Voltage. This pin should be connected to the Smart Card  $V_{\text{CC}}$  contact. The 5V/3V pin determines the  $V_{\text{CC}}$  output voltage.

The  $V_{\text{CC}}$  pin is protected against short circuits by comparing the actual output voltage with an internal reference voltage. If  $V_{\text{CC}}$  is below its correct level (for as little as 5 $\mu\text{s}$ ) the LTC1756 switches to the Alarm state (see the State Diagram). The  $V_{\text{CC}}$  pin requires a 10 $\mu\text{F}$  charge storage capacitor to ground. For optimum performance a low ESR ceramic capacitor should be used.

During the Idle and Alarm states the  $V_{\text{CC}}$  pin is rapidly discharged to ground to comply with the deactivation requirements of the EMV and ISO-7816 specifications.

**I/O (Pin 6):** (Input/Output) Smart Card Side Data I/O Pin. This pin is used for bidirectional data transfer between the microcontroller and the Smart Card. It should be connected

to the Smart Card I/O contact. The Smart Card I/O pin must be able to sink up to 250 $\mu\text{A}$  when driving the I/O pin low due to the pull-up current source. The I/O pin becomes a low impedance to ground during the Idle state. It does not become active until  $\overline{\text{READY}}$  goes low indicating that  $V_{\text{CC}}$  is stable.

Once  $\overline{\text{READY}}$  is low, the I/O pin is protected against short circuits to  $V_{\text{CC}}$  by current limiting to 5mA maximum.

The DATA-I/O channel is bidirectional for half-duplex transmissions. Its idle state is H-H. Once an L is detected on one side of the channel the direction of transmission is established. Specifically, the side which received an L first is now the input, and the opposite side is the output. Transmission from the output side back to the input side is inhibited, thereby preventing a latch condition. Once the input side releases its L, both sides return to H, and the channel is now ready for a new L to be transmitted in either direction. If an L is forced externally on the output side, and it persists until after the L on the input side is released, this illegal input will not be transmitted to the input side because the transmission direction will not have changed. The direction of transmission can only be established from the idle (H-H) state and is determined by the first receipt of an L on either side.

**RST (Pin 7):** (Output) Level-Shifted Reset Output Pin. This pin should be connected to the Smart Card RST contact. The RST pin becomes a low impedance to ground during the Idle state (see the State Diagram). The reset channel does not become active until the  $\overline{\text{READY}}$  signal goes low indicating that  $V_{\text{CC}}$  is stable.

Short-circuit protection is provided on the RST pin by comparing RST with  $R_{\text{IN}}$ . If these signals differ for several microseconds then the LTC1756 switches to the Alarm state. This fault checking is only performed after the  $V_{\text{CC}}$  pin has reached its final value (as indicated by the  $\overline{\text{READY}}$  pin).

**CLK (Pin 8):** (Output) Level-Shifted Clock Output Pin. This pin should be connected to the Smart Card CLK contact. The CLK pin becomes a low impedance to ground during the Idle state (see the State Diagram). The clock channel does not become active until the  $\overline{\text{READY}}$  signal goes low indicating that  $V_{\text{CC}}$  is stable.

## PIN FUNCTIONS

Short-circuit protection is provided on the CLK pin by comparing CLK with  $C_{IN}$ . If these signals differ for several microseconds then the LTC1756 switches to the Alarm state. This fault checking is only performed after the  $V_{CC}$  pin has reached its final value (as indicated by the  $\overline{READY}$  pin).

The clock channel is optimized for signal integrity in order to meet the stringent duty cycle requirements of the EMV specification. Therefore, to reduce power in low power applications, clock stop mode is recommended when data is not being exchanged.

**CIN (Pin 9):** (Input) Clock Input Pin from the Microcontroller. During the Active state this signal appears on the CLK pin after being level-shifted and buffered.

**RIN (Pin 10):** (Input) Reset Input Pin from the Microcontroller. During the Active state this signal appears on the RST pin after being level-shifted and buffered.

**DATA (Pin 11):** (Input/Output) Microcontroller Side Data I/O Pin. This pin is used for bidirectional data transfer between the microcontroller and the Smart Card. The microcontroller data pin must be open drain and must be able to sink up to 250 $\mu$ A when driving the DATA pin low due to the pull-up current source. The DATA pin becomes high impedance during the Idle state (see the State Diagram). It does not become active until the  $\overline{READY}$  signal goes low indicating that  $V_{CC}$  is stable.

**C<sup>+</sup>, C<sup>-</sup> (Pins 12, 13):** Charge Pump Flying Capacitor Terminals. Optimum values for the flying capacitor range from 0.68 $\mu$ F to 1 $\mu$ F. Best performance is achieved with a low ESR X7R ceramic capacitor.

**$\overline{READY}$  (Pin 14):** (Output) Readiness Indicator of the Smart Card Supply Voltage ( $V_{CC}$ ). When the LTC1756 is placed in the Active state the soft start feature slowly ramps the  $V_{CC}$  voltage. A low on the  $\overline{READY}$  pin indicates that  $V_{CC}$  has reached its final value.

The  $\overline{READY}$  pin is configured as an open-drain pull-down with a weak pull-up current source.

The  $\overline{READY}$  pin also indicates if the LTC1756 is in Alarm mode. The LTC1756 detects faults such as  $V_{CC}$  underrange for at least 5 $\mu$ s, overtemperature shutdown, CLK or RST invalid output levels and card removal during Active state. CLK or RST invalid and overtemperature faults are detected only after  $V_{CC}$  has reached its final value.  $V_{CC}$  underrange and card removal during Active faults are detected at any time during the Active period (i.e., once  $\overline{PWR} = 0V$ ).

If the LTC1756 has been activated normally and  $V_{CC}$ , the card voltage, has reached its final value then  $\overline{READY}$  will go low indicating normal operation. If, following this, a fault occurs and the LTC1756 enters the Alarm state, the  $\overline{READY}$  pin will return high.

In the event that a fault precedes the activation of  $V_{CC}$ , such as a direct short circuit from  $V_{CC}$  to GND, the LTC1756 will attempt to operate until the fault is detected and then automatically shut down and enter the Alarm state. In this case the  $\overline{READY}$  pin will never go low after the command to start the smart card is given (i.e.,  $\overline{PWR} = 0V$ ).

If the LTC1756 enters the Alarm state it can only be cleared by returning the  $\overline{PWR}$  pin high.

**$\overline{CARD}$  (Pin 15):** (Output) Level-Shifted and Debounced PRES Signal from the Smart Card Acceptor Switch. When a valid card indication appears, this pin communicates the presence of the Smart Card to the microcontroller. The  $\overline{CARD}$  pin has an open-drain active pull-down with a weak pull-up current source. The debounce circuit ensures that a card has been present for a continuous period of at least 40ms before asserting  $\overline{CARD}$  low. The  $\overline{CARD}$  pin returns high within 50 $\mu$ s of card removal.

**5V/3V (Pin 16):** (Input) Controls the output voltage ( $V_{CC}$ ) of the DC/DC converter during the Active state. A valid high sets  $V_{CC}$  to 5V. A valid low sets  $V_{CC}$  to 3V. The 5V/3V pin is latched on the falling edge of the  $\overline{PWR}$  pin. When  $\overline{PWR}$  is low, changes on the 5V/3V pin are ignored. To change the voltage on  $V_{CC}$  the LTC1756 must first be returned to the Idle state by bringing the  $\overline{PWR}$  pin high.

**BLOCK DIAGRAM**

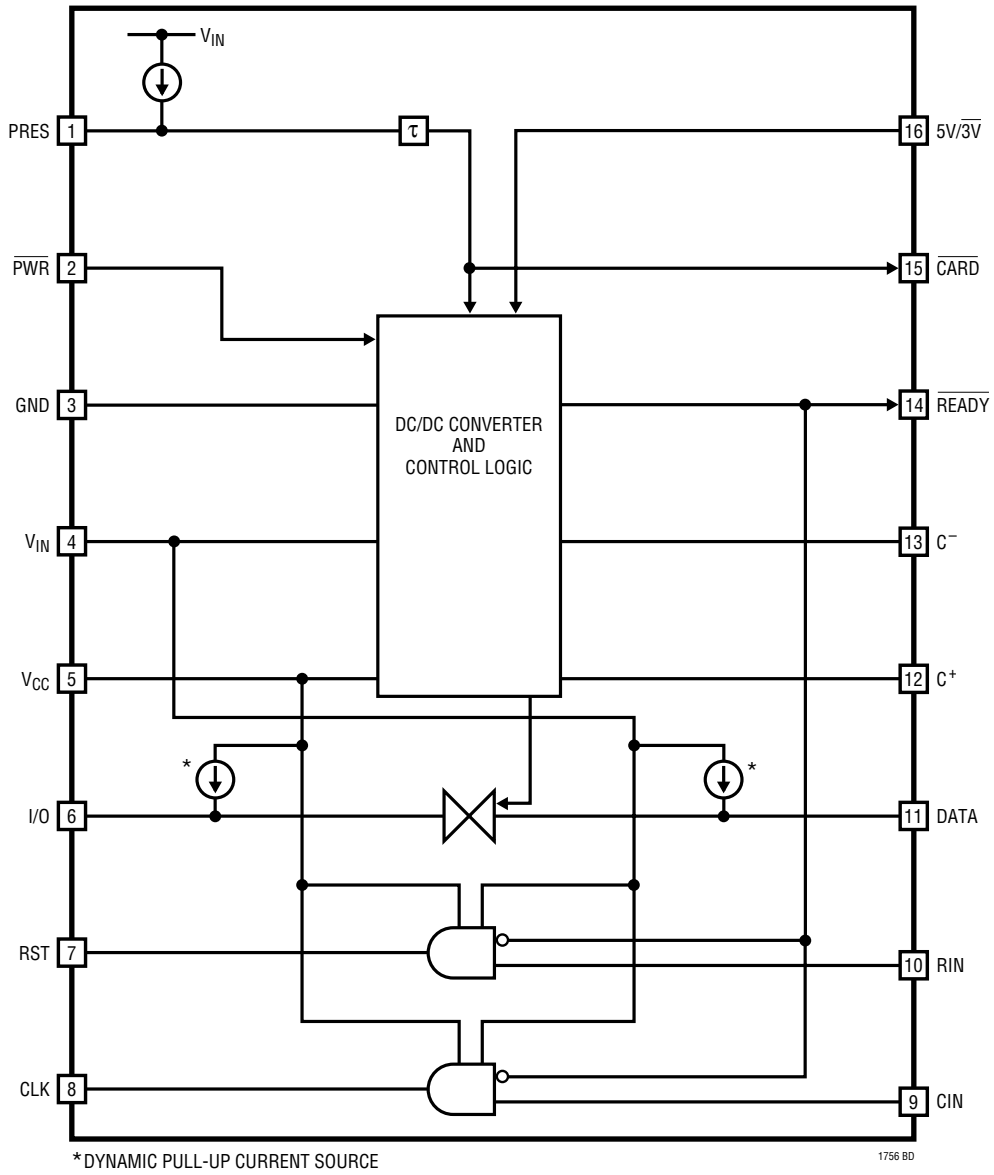

## APPLICATIONS INFORMATION

### 10kV ESD Protection

All Smart Card pins (CLK, RST, I/O,  $V_{CC}$  and GND) can withstand over 10kV of human body model ESD in situ. In order to ensure proper ESD protection, careful board layout is required. The GND pin should be tied directly to a ground plane. The  $V_{CC}$  capacitor should be located very close to the  $V_{CC}$  pin and tied immediately to the ground plane.

### Capacitor Selection

The style and value of capacitors used with the LTC1756 determine several parameters such as output ripple voltage, charge pump strength, Smart Card switch debounce time and  $V_{CC}$  discharge rate.

Due to the switching nature of a capacitive charge pump, low equivalent series resistance (ESR) capacitors are recommended for the capacitors at  $V_{IN}$  and  $V_{CC}$ . Whenever the flying capacitor is switched to the  $V_{CC}$  charge storage capacitor, considerable current flows. The product of this high current and the ESR of the output capacitor can generate substantial voltage spikes on the  $V_{CC}$  output. These spikes may cause problems with the Smart Card or may interfere with the regulation loop of the LTC1756. Therefore, ceramic or tantalum capacitors are recommended rather than higher ESR aluminum capacitors. Between ceramic and tantalum, ceramic capacitors generally have the lowest ESR. Some manufacturers have developed low ESR tantalum capacitors but they can be expensive and may still have higher ESR than ceramic types. Thus, while they cannot be avoided, ESR spikes will typically be lowest when using ceramic capacitors.

For ceramic capacitors there are several different materials available to choose from. The choice of ceramic material is generally based on factors such as available capacitance, case size, voltage rating, electrical performance and cost. For example, capacitors made of Y5V material have high packing density, which provides high capacitance for a given case size. However, Y5V capacitors tend to lose considerable capacitance over the  $-40^{\circ}\text{C}$  to  $85^{\circ}\text{C}$  temperature range. X7R ceramic capacitors are more stable over temperature but don't provide the high packing density. Therefore, large capacitance values are generally not available in X7R ceramic.

The value and style of the flying capacitor are important not only for the charge pump but also because they provide the large debounce time for the Smart Card detection channel. A  $0.68\mu\text{F}$  X7R capacitor is a good choice for the flying capacitor because it provides fairly constant capacitance over temperature and its value is not prohibitively large.

The charge storage capacitor on the  $V_{CC}$  pin determines the ripple voltage magnitude and the discharge time of the Smart Card voltage. To minimize ripple, generally, a large value is needed. However, to meet the  $V_{CC}$  discharge rate specification, the value should not exceed  $20\mu\text{F}$ . A  $10\mu\text{F}$  capacitor can be used but the ripple magnitude will be higher leading to worse apparent DC load regulation. Typically a  $15\mu\text{F}$  to  $18\mu\text{F}$  Y5V ceramic capacitor is the best choice for the  $V_{CC}$  charge storage capacitor. For best performance, this capacitor should be connected as close as possible to the  $V_{CC}$  and GND pins. Note that most of the electrostatic discharge (ESD) current on the Smart Card pins is absorbed by this capacitor.

## APPLICATIONS INFORMATION

The bypass capacitor at  $V_{IN}$  is also important. Large dips on the input supply due to ESR may cause problems with the internal circuitry of the LTC1756. A good choice for the input bypass capacitor is a 10 $\mu$ F Y5V style ceramic

### Dynamic Pull-Up Current Sources

The current sources on the bidirectional pins (DATA and I/O) are dynamically activated to achieve a fast rise time with a relatively small static current (Figure 1). Once a bidirectional pin is relinquished, a small start-up current begins to charge the node. An edge rate detector determines if the pin is released by comparing its slew rate with an internal reference value. If a valid transition is detected, a large pull-up current enhances the edge rate on the node. The higher slew rate corroborates the decision to charge the node thereby effecting a dynamic form of hysteresis. Once the node has reached the power supply voltage the internal comparator requires several hundred nanoseconds to reset. Pulling down on the pin before the reset delay expires will result in a momentary contention and a higher current flow. Therefore, the comparator delay sets the upper limit on the maximum data rate of the bidirectional channels to about 500kHz.

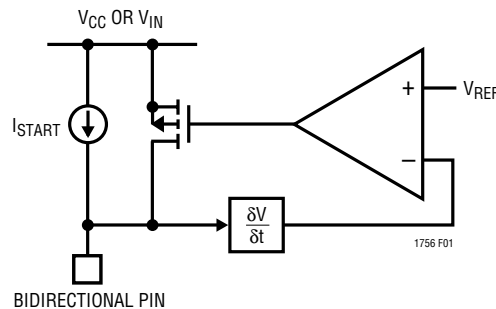

Figure 1. Dynamic Pull-Up Current Sources

### Low Power Operation

The LTC1756 is inherently a low power device. When there is no Smart Card present the supply current is less than 2.5 $\mu$ A. When a Smart Card is present the LTC1756 operates with a quiescent current of only 75 $\mu$ A, thus the majority of power is consumed by charge pump losses and the card itself. If the card can be made to consume less power during idle times a significant power savings will be achieved. Whenever possible Clock Stop Mode should be used (or alternatively a very low “idling” clock speed). Furthermore, in the Active state, the bidirectional pins should all be relinquished whenever possible since there is some static current flow when a bidirectional pin is pulled down.

### Overtemperature Fault Protection

An overtemperature circuit disables the chip and places the LTC1756 in the Alarm state if the IC’s junction temperature exceeds 150°C.



## APPLICATIONS INFORMATION

### Self-Start Mode

By connecting the  $\overline{\text{CARD}}$  pin to the  $\overline{\text{PWR}}$  pin the LTC1756 can be made to start up automatically when a Smart Card is detected (Figure 2). In this mode, the  $\overline{\text{READY}}$  pin becomes an interrupt signal indicating to the microcontroller that a Smart Card is present and that  $V_{\text{CC}}$ , the charge pump voltage, is at its final value. The Smart Card remains powered as long as it is detected by the  $\overline{\text{PRES}}$  pin. When the Smart Card is removed the LTC1756 will automatically be deactivated by the fault detection circuitry.

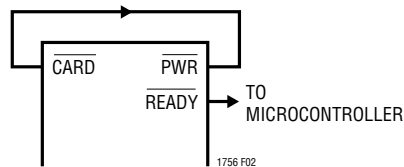

Figure 2. Self-Start Mode

### Deactivation Sequence

For maximum flexibility the Smart Card can be deactivated either manually or automatically. In manual mode the deactivation is controlled by explicitly manipulating the LTC1756 input and control pins ( $\overline{\text{DATA}}$ ,  $\overline{\text{RIN}}$  and  $\overline{\text{CIN}}$  followed by  $\overline{\text{PWR}}$ ). In automatic mode the  $\overline{\text{PWR}}$  pin is used to perform the built-in deactivation sequence. Once  $\overline{\text{PWR}}$  is brought high the built-in deactivation sequence occurs as follows:

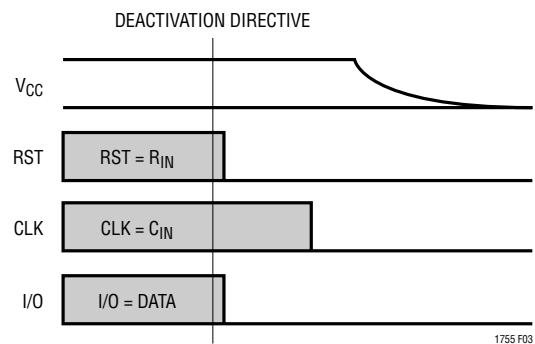

Figure 3. Deactivation Sequence

In the event of a fault, the LTC1756 automatically implements the built-in deactivation sequence.

## APPLICATIONS INFORMATION

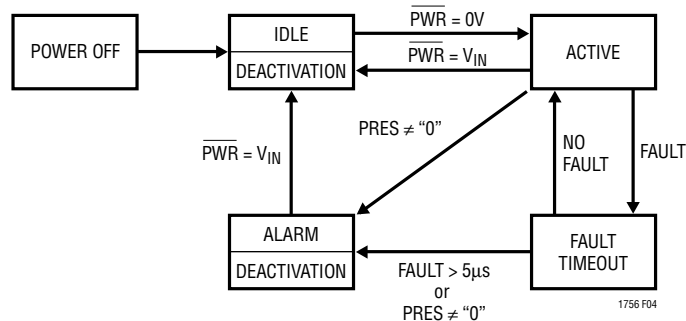

Figure 4. LTC1756 State Diagram

## State Definitions

## IDLE/DEACTIVATION

$V_{CC}$ , RST, CLK, I/O = L

$\overline{\text{READY}}$ , DATA = Z

$\overline{\text{CARD}} = \text{PRES}$

Once the LTC1756 enters the Idle/Deactivation state the deactivation sequence begins. The deactivation sequence will continue until  $V_{CC}$  is discharged to approximately 1V. An activation command ( $\overline{\text{PWR}} = 0\text{V}$ ) will only be acknowledged once this occurs.

## ALARM/DEACTIVATION

The only possible next state is Idle/Deactivation which is achieved by disabling the LTC1756 via the  $\overline{\text{PWR}}$  pin (i.e.,  $\overline{\text{PWR}} = V_{IN}$ ).

The alarm indication can be cleared by rapidly cycling the  $\overline{\text{PWR}}$  pin. However, a new activation cycle will not begin until  $V_{CC}$  is or has dropped below approximately 1V.

## ACTIVE

$V_{CC} = 3\text{V}$  or  $5\text{V}$  (as determined by the  $5\text{V}/\overline{3\text{V}}$  pin)

RST =  $R_{IN}$ , CLK =  $C_{IN}$

I/O, DATA = Ready for data (after  $\overline{\text{READY}}$  becomes low)

$\overline{\text{CARD}} = \text{PRES}$

## FAULT TIMEOUT

Same as Active except:

The duration of a fault is being measured. If the fault duration exceeds  $5\mu\text{s}$  then the Alarm/Deactivation state follows. If the fault duration is less than  $5\mu\text{s}$ , then the device is returned to the Active state.

**PACKAGE DESCRIPTION**

Dimensions in inches (millimeters) unless otherwise noted.

**GN Package**  
**16-Lead Plastic SSOP (Narrow 0.150)**  
 (LTC DWG # 05-08-1641)

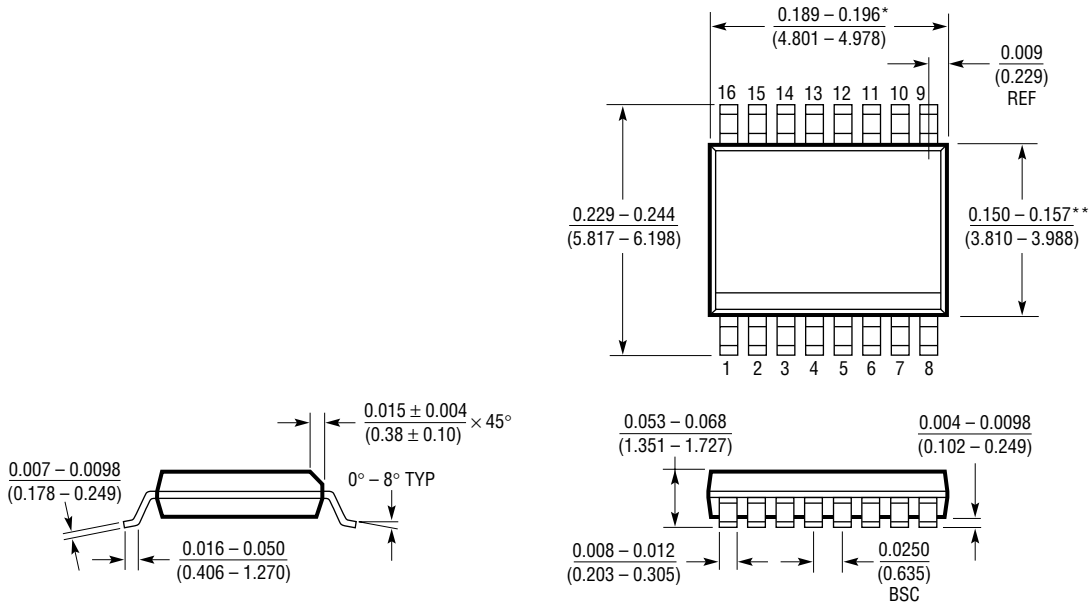

\* DIMENSION DOES NOT INCLUDE MOLD FLASH. MOLD FLASH SHALL NOT EXCEED 0.006" (0.152mm) PER SIDE  
 \*\* DIMENSION DOES NOT INCLUDE INTERLEAD FLASH. INTERLEAD FLASH SHALL NOT EXCEED 0.010" (0.254mm) PER SIDE

GN16 (SSOP) 1098

**RELATED PARTS**

PART NUMBER	DESCRIPTION	COMMENTS
LTC1514/LTC1515	Micropower Step-Up/Step-Down Inductorless DC/DC Converters	Regulated Output Up to 50mA, $V_{IN}$ from 2V to 10V, SO-8 Package
LTC1516	Micropower Regulated 5V Charge Pump	5V/50mA Output from 2V to 5V Input, SO-8 Package
LTC1555/LTC1556	SIM Power Supply and Level Translator	Step-Up/Step-Down Charge Pump + SIM Level Translators, >10kV ESD
LTC1754-5	5V Charge Pump with Shutdown in SOT-23	$V_{IN}$ from 2.7V to 5.5V, 50mA Output with $V_{IN} \geq 3V$
LTC1755	Smart Card Interface with C4, C8 Pins	$V_{IN}$ from 2.7V to 6V, 10kV ESD On All Smart Card Pins, 60 $\mu$ A Operating Current
LTC1986	3V/5V SIM Power Supply in SOT-23	$V_{IN}$ from 2.6V to 4.4V, 3V/5V Output at 10mA