

Low Noise, 8th Order, Clock Sweepable Cauer Lowpass Filter

FEATURES

- 8th Order Filter in a 14-Pin Package
- 80dB or More Stopband Attenuation at $2 \times f_{CUTOFF}$
- 50:1 f_{CLOCK} to f_{CUTOFF} Ratio (Cauer)
100:1 f_{CLOCK} to f_{-3dB} Ratio (Transitional)
- 135 μ V_{RMS} Total Wideband Noise
- 0.03% THD or Better
- 100kHz Maximum f_{CUTOFF} Frequency
- Operates up to $\pm 8V$ Power Supplies
- Input Frequency Range up to 50 Times the Filter Cutoff Frequency

APPLICATIONS

- Antialiasing Filters
- Telecom Filters
- Sinewave Generators

DESCRIPTION

The LTC1064-4 is an 8th order, clock sweepable Cauer low-pass switched capacitor filter. An external TTL or CMOS clock programs the value of the filter's cutoff frequency. With pin 10 at V^+ , the f_{CLOCK} to f_{CUTOFF} ratio is 50:1; the filter has a Cauer response and with compensation the passband ripple is $\pm 0.1dB$. The stopband attenuation is 80dB at $2 \times f_{CUTOFF}$. Cutoff frequencies up to 100kHz can be achieved. With pin 10 at V^- , the f_{CLOCK} to f_{-3dB} ratio is 100:1, the filter has a transitional Butterworth-Cauer response with lower noise and lower delay nonlinearity than the Cauer response. The stopband attenuation at $2.5 \times f_{-3dB}$ is 92dB. Cutoff frequencies up to 50kHz can be achieved.

The LTC1064-4 features low noise and low harmonic distortion even when input voltages up to $3V_{RMS}$ are applied. The LTC1064-4 overall performance competes with equivalent multi-op amp active realizations. The LTC1064-4 is pin compatible with the LTC1064-1, LTC1064-2, and LTC1064-3.

The LTC1064-4 is manufactured using Linear Technology's enhanced LTCMOS™ silicon gate process.

TYPICAL APPLICATION

8th Order Clock Sweepable Lowpass Elliptic Filter

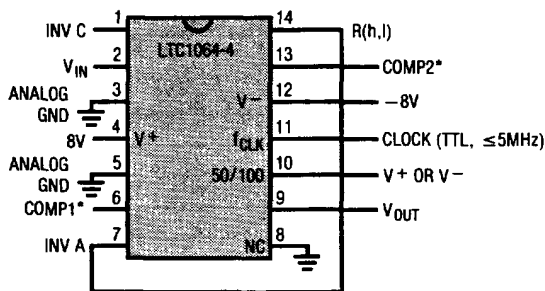

*FOR FREQUENCIES ABOVE 20kHz AND MINIMUM PASSBAND RIPPLE REFER TO THE PIN DESCRIPTION SECTION FOR COMPENSATION GUIDELINES.
 NOTE: THE POWER SUPPLIES SHOULD BE BYPASSED BY A 0.1 μ F CAPACITOR CLOSE TO THE PACKAGE.
 BYPASSING PIN 10 WITH 0.1 μ F CAPACITOR REDUCES CLOCK FEEDTHROUGH. THE CONNECTION BETWEEN PINS 7 AND 14 SHOULD BE PHYSICALLY DONE UNDER THE PACKAGE.

Frequency Response

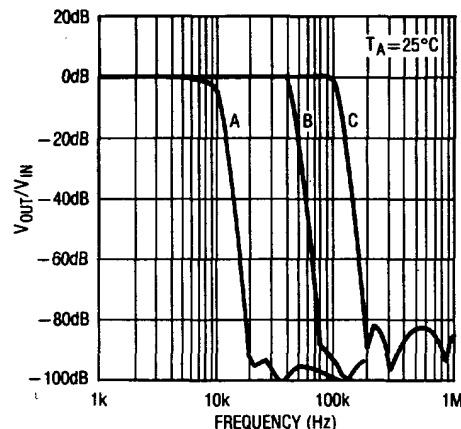

CURVE A: $f_{CLK} = 1MHz$, 100:1
 CURVE B: $f_{CLK} = 2MHz$, 50:1
 CURVE C: $f_{CLK} = 5MHz$, 50:1
 $C_{COMP1} = 30pF$
 $C_{COMP2} = 18pF$

LTC1064-4

ABSOLUTE MAXIMUM RATINGS

Total Supply Voltage (V^+ to V^-) 16.5V
 Input Voltage at Any Pin $V^- - 0.3V \leq V_{IN} \leq V^+ + 0.3V$
 Power Dissipation 400mW
 Storage Temperature Range -65°C to 150°C

Lead Temperature (Soldering, 10 sec.) 300°C
 Operating Temperature Range
 LTC1064-4M -55°C to 125°C
 LTC1064-4C -40°C to 85°C

PACKAGE/ORDER INFORMATION

TOP VIEW	ORDER PART NUMBER	TOP VIEW	ORDER PART NUMBER
<p>J PACKAGE 14-LEAD CERAMIC DIP</p> <p>N PACKAGE 14-LEAD PLASTIC DIP</p>	<p>LTC1064-4MJ LTC1064-4CJ LTC1064-4CN</p>	<p>S PACKAGE 16-LEAD PLASTIC SOL</p>	<p>LTC1064-4CS</p>

ELECTRICAL CHARACTERISTICS

$V_S = \pm 7.5\text{V}$, 50:1, $f_{CLK} = 1\text{MHz}$, $f_C = 20\text{kHz}$, $R_I = 10\text{k}\Omega$, $T_A = 25^\circ$, TTL clock input level unless otherwise specified.

PARAMETER	CONDITIONS	MIN	TYP	MAX	UNITS
Passband Gain	Referenced to 0dB, 1Hz – $0.05f_{CUTOFF}$	• -0.5	0.0002	0.1	dB
Gain TempCo			$20 \pm 1\%$		dB/°C
Passband Edge Frequency, f_C					kHz
Gain at f_C	Referenced to Passband Gain, $f_C = 20\text{kHz}$	• -0.4	21.5	0.7	dB
-3dB Frequency	50:1 (Cauer Response)		10		kHz
	100:1 (Transitional Response)				kHz
Passband Ripple (Note 1)	$0.1f_C$ to $0.95f_C$ Referenced to Passband Gain	• 0		0.75	dB
Stopband Attenuation	At $1.7f_{CUTOFF}$	• -56	-60		dB
Stopband Attenuation	At $2f_{CUTOFF}$		-80		dB
Input Frequency Range	50:1, Pin 10 at V^+	0		f_{CLK}	kHz
	100:1, Pin 10 at V^-	0		$f_{CLK}/2$	kHz
Output Voltage Swing and Operating Input Voltage Range	$V_S = \pm 2.37\text{V}$	• ± 1.1			V
	$V_S = \pm 5\text{V}$	• ± 3.1			V
	$V_S = \pm 7.5\text{V}$	• ± 5.0			V
Total Harmonic Distortion	$V_S = \pm 5\text{V}$, Input = $1V_{RMS}$ at 1kHz		0.015		%
	$V_S = \pm 7.5\text{V}$, Input = $3V_{RMS}$ at 1kHz		0.03		%
Wideband Noise	$V_S = \pm 5\text{V}$, Input = GND 1Hz-999kHz		120		μV_{RMS}
	$V_S = \pm 7.5\text{V}$, Input = GND 1Hz-999kHz		135		μV_{RMS}
Output DC Offset	$V_S = \pm 7.5\text{V}$		± 50	± 160	mV
Output DC Offset TempCo	$V_S = \pm 5\text{V}$		-100		$\mu V/^\circ\text{C}$
	$V_S = \pm 7.5\text{V}$		-200		$\mu V/^\circ\text{C}$
Input Impedance		9	13		k Ω
Output Impedance	$f_{OUT} = 10\text{kHz}$		2		Ω
Output Short Circuit Current	Source/Sink		3/1		mA
Clock Feedthrough	Input = GND		200		μV_{RMS}
Maximum Clock Frequency	50% Duty Cycle, $V_S = \pm 7.5\text{V}$ (Note 2)			5	MHz
Power Supply Current	$V_S = \pm 2.37\text{V}$, $f_{CLK} = 1\text{MHz}$	•	11	18	mA
	$V_S = \pm 5\text{V}$, $f_{CLK} = 1\text{MHz}$	•	14	20	mA
	$V_S = \pm 7.5\text{V}$, $f_{CLK} = 1\text{MHz}$	•	17	24	mA
		•		32	mA
Power Supply Voltage Range		• ± 2.37		± 8	V

The • denotes the specifications which apply over the full operating temperature range.

Note 1: For tighter passband ripple specifications please consult with LTC's marketing.

Note 2: Not tested, guaranteed by design.

TYPICAL PERFORMANCE CHARACTERISTICS

Graph 1. Gain vs Frequency

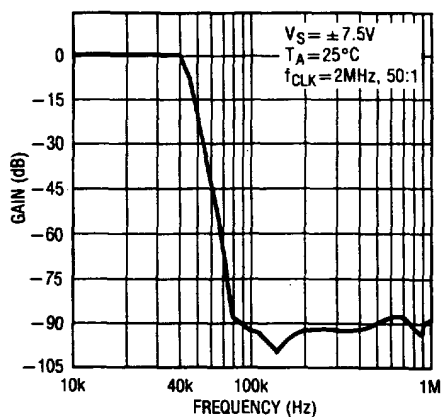

Graph 2. Passband Phase Shift vs Frequency

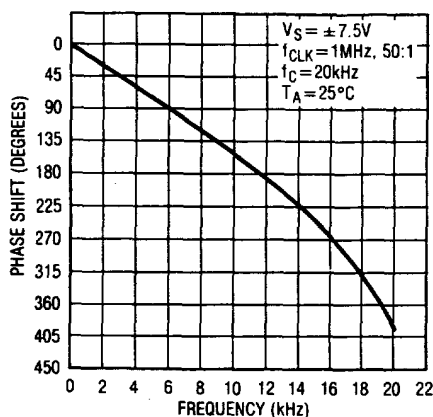

Graph 3. Passband Group Delay

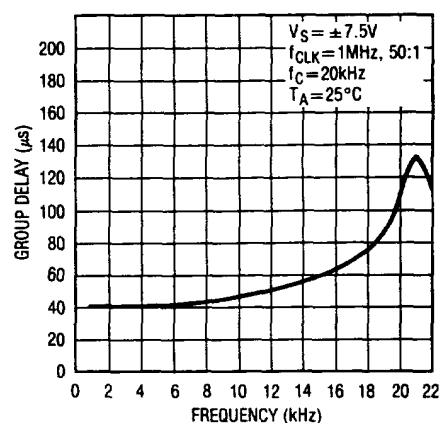

Graph 4. Gain vs Frequency with Compensation

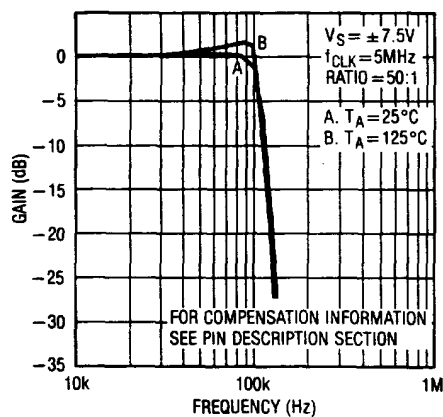

Graph 5. Device to Device Phase Matching

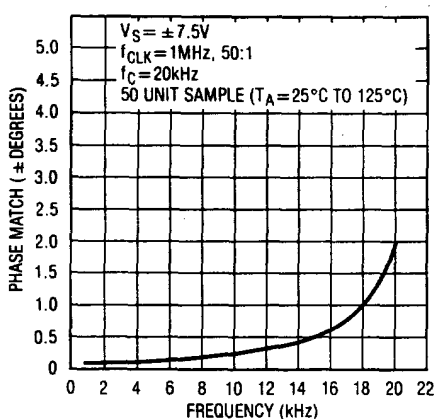

Graph 6. Total Harmonic Distortion

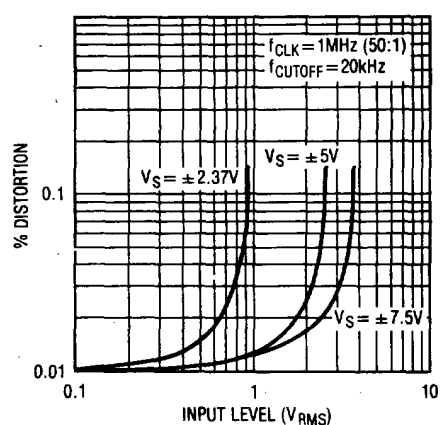

Graph 7. Power Supply Current vs Power Supply Voltage

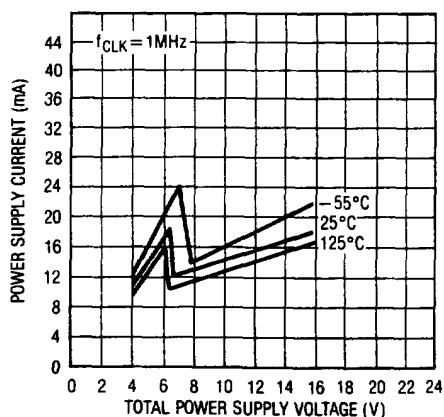

Graph 8. Transient Response
 $f_{CLK} = 1\text{MHz}$, Ratio = 50:1,
 $f_C = 20\text{kHz}$, $V_S = \pm 7.5\text{V}$, 1kHz,
 Square Wave Input

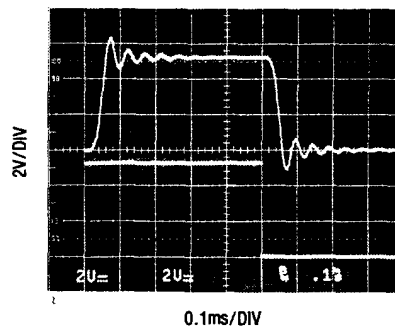

TYPICAL PERFORMANCE CHARACTERISTICS

Table 1. Wideband Noise (μV_{RMS}). Input Grounded, $f_{\text{CLK}} = 1\text{MHz}$.

PIN 10 TO	$f_{\text{CLK}}/f_{\text{CUTOFF}}$	$V_S = \pm 2.37\text{V}$	$V_S = \pm 5\text{V}$	$V_S = \pm 7.5\text{V}$
		NOISE (μV_{RMS})	NOISE (μV_{RMS})	NOISE (μV_{RMS})
V^+	50:1	120	135	145
V^-	100:1	100	120	130

Table 2. Gain/Phase, Pin 10 at V^+ . Typical Response.
 $f_{\text{CUTOFF}} = 1\text{kHz}$, $V_S = \pm 5\text{V}$, $T_A = 25^\circ\text{C}$ $f_{\text{CLK}} = 50\text{kHz}$ Ratio = 50:1

FREQUENCY	GAIN	PHASE
0.200kHz	-0.075dB	-59.990 deg
0.400kHz	-0.050dB	-122.400 deg
0.600kHz	0.020dB	169.300 deg
0.800kHz	0.060dB	88.500 deg
1.000kHz	0.090dB	-26.100 deg
1.200kHz	-15.640dB	-175.100 deg
1.400kHz	-34.700dB	126.500 deg
1.600kHz	-51.700dB	87.600 deg
1.800kHz	-68.600dB	38.400 deg
2.000kHz	-84.110dB	-47.860 deg

Table 3. Gain/Delay, Pin 10 at V^+ . Typical Response.
 $f_{\text{CUTOFF}} = 1\text{kHz}$, $V_S = \pm 5\text{V}$, $T_A = 25^\circ\text{C}$ $f_{\text{CLK}} = 50\text{kHz}$ Ratio = 50:1

FREQUENCY	GAIN	DELAY
0.200kHz	-0.074dB	0.844ms
0.300kHz	-0.070dB	0.867ms
0.400kHz	-0.050dB	0.899ms
0.500kHz	-0.020dB	0.949ms
0.600kHz	0.020dB	1.021ms
0.700kHz	0.050dB	1.122ms
0.800kHz	0.060dB	1.275ms
0.900kHz	0.120dB	1.592ms
1.000kHz	0.090dB	2.160ms
1.100kHz	-5.020dB	2.070ms
1.200kHz	-15.650dB	1.288ms

Table 4. Gain/Phase, Pin 10 at V^- . Typical Response.
 $f_{-3\text{dB}} = 1\text{kHz}$, $V_S = \pm 5\text{V}$, $T_A = 25^\circ\text{C}$ $f_{\text{CLK}} = 100\text{kHz}$ Ratio = 100:1

FREQUENCY	GAIN	PHASE
0.200kHz	-0.179dB	-60.090 deg
0.400kHz	-0.440dB	-122.000 deg
0.600kHz	-0.810dB	170.800 deg
0.800kHz	-1.480dB	91.900 deg
1.000kHz	-3.500dB	-16.300 deg
1.200kHz	-17.720dB	-140.500 deg
1.400kHz	-35.700dB	164.800 deg
1.600kHz	-52.700dB	135.000 deg
1.800kHz	-71.900dB	114.000 deg
2.000kHz	-96.160dB	-49.670 deg

Table 5. Gain/Delay, Pin 10 at V^- . Typical Response.
 $f_{-3\text{dB}} = 1\text{kHz}$, $V_S = \pm 5\text{V}$, $T_A = 25^\circ\text{C}$ $f_{\text{CLK}} = 100\text{kHz}$ Ratio = 100:1

FREQUENCY	GAIN	DELAY
0.200kHz	-0.174dB	0.842ms
0.300kHz	-0.300dB	0.861ms
0.400kHz	-0.440dB	0.888ms
0.500kHz	-0.610dB	0.933ms
0.600kHz	-0.810dB	0.999ms
0.700kHz	-1.090dB	1.095ms
0.800kHz	-1.480dB	1.242ms
0.900kHz	-2.080dB	1.503ms
1.000kHz	-3.500dB	1.832ms
1.100kHz	-8.720dB	1.724ms
1.200kHz	-17.720dB	1.183ms

Table 6. Gain/Phase, Pin 10 at GND.
 $V_S = \pm 5\text{V}$, $T_A = 25^\circ\text{C}$

FREQUENCY	GAIN	PHASE
0.200kHz	-0.383dB	-47.140 deg
0.400kHz	-1.000dB	-92.000 deg
0.600kHz	-1.300dB	-134.300 deg
0.800kHz	-0.280dB	-178.800 deg
1.000kHz	2.670dB	109.200 deg
1.200kHz	-3.500dB	6.000 deg
1.400kHz	-12.510dB	-47.400 deg
1.600kHz	-20.000dB	-88.800 deg
1.800kHz	-27.300dB	-127.800 deg
2.000kHz	-35.000dB	-164.200 deg

TYPICAL PERFORMANCE CHARACTERISTICS

Table 7. Gain/Phase for Figure 6.
 Typical Response, Pin 10 at V⁺, f_{CUTOFF} = 40kHz
 V_S = ±7.5V, f_{CLK} = 2MHz, Ratio = 50:1

FREQUENCY	GAIN	PHASE
10.000kHz	-0.094dB	-75.900 deg
12.000kHz	-0.100dB	-91.400 deg
14.000kHz	-0.090dB	-107.200 deg
16.000kHz	-0.080dB	-123.300 deg
18.000kHz	-0.060dB	-139.600 deg
20.000kHz	-0.040dB	-156.500 deg
22.000kHz	-0.020dB	-173.800 deg
24.000kHz	0.000dB	168.200 deg
26.000kHz	0.020dB	149.400 deg
28.000kHz	0.030dB	130.000 deg
30.000kHz	0.020dB	109.400 deg
32.000kHz	0.010dB	87.700 deg
34.000kHz	-0.020dB	64.600 deg
36.000kHz	-0.030dB	39.500 deg
38.000kHz	-0.010dB	11.400 deg
40.000kHz	-0.070dB	-22.000 deg
42.000kHz	-0.920dB	-64.100 deg
44.000kHz	-4.000dB	-110.100 deg
46.000kHz	-8.970dB	-147.000 deg
48.000kHz	-14.320dB	-173.500 deg
50.000kHz	-19.460dB	166.800 deg

Table 8. Gain/Phase for Figure 7.
 Typical Response, Pin 10 at V⁺, f_{CUTOFF} = 100kHz
 V_S = ±7.5V, T_A = 25°C, f_{CLK} = 5MHz Ratio = 50:1

FREQUENCY	GAIN	PHASE
10.000kHz	-0.096dB	-32.390 deg
20.000kHz	-0.100dB	-64.900 deg
30.000kHz	-0.080dB	-98.100 deg
40.000kHz	-0.040dB	-132.300 deg
50.000kHz	0.020dB	-168.200 deg
60.000kHz	0.070dB	153.600 deg
70.000kHz	0.040dB	112.100 deg
80.000kHz	-0.120dB	66.400 deg
90.000kHz	-0.460dB	14.600 deg
100.000kHz	-1.310dB	-49.300 deg
110.000kHz	-5.640dB	-129.000 deg
120.000kHz	-14.530dB	167.800 deg
130.000kHz	-23.800dB	126.700 deg
140.000kHz	-32.600dB	96.200 deg
150.000kHz	-41.000dB	71.300 deg
160.000kHz	-49.200dB	49.200 deg
170.000kHz	-57.500dB	29.000 deg
180.000kHz	-66.500dB	9.800 deg
190.000kHz	-77.770dB	-2.320 deg
200.000kHz	-92.050dB	76.740 deg

Table 9. Gain/Phase for Figure 7.
 Typical Response, Pin 10 at V⁺, f_{CUTOFF} = 100kHz
 V_S = ±7.5V, T_A = 125°C, f_{CLK} = 5MHz Ratio = 50:1

FREQUENCY	GAIN	PHASE
10.000kHz	-0.071dB	-33.800 deg
20.000kHz	-0.040dB	-67.800 deg
30.000kHz	0.050dB	-102.500 deg
40.000kHz	0.190dB	-138.300 deg
50.000kHz	0.410dB	-176.100 deg
60.000kHz	0.670dB	143.100 deg
70.000kHz	0.920dB	98.400 deg
80.000kHz	1.150dB	48.200 deg
90.000kHz	1.530dB	-10.900 deg
100.000kHz	1.110dB	-96.500 deg

FREQUENCY	GAIN	PHASE
110.000kHz	-7.420dB	172.100 deg
120.000kHz	-18.240dB	119.400 deg
130.000kHz	-28.000dB	83.300 deg
140.000kHz	-37.000dB	54.000 deg
150.000kHz	-45.700dB	-27.600 deg
160.000kHz	-54.300dB	2.100 deg
170.000kHz	-63.300dB	-24.900 deg
180.000kHz	-73.610dB	-60.210 deg
190.000kHz	-85.300dB	-138.990 deg
200.000kHz	-83.390dB	129.580 deg

PIN DESCRIPTION

Power Supply Pins (4, 12)

The V^+ (pin 4) and V^- (pin 12) should be bypassed with a $0.1\mu\text{F}$ capacitor to an adequate analog ground. Low noise, non-switching power supplies are recommended. **To avoid latch up when the power supplies exhibit high turn-on transients, a 1N5817 Schottky diode should be added from the V^+ and V^- pins to ground, Figures 1 and 2.**

Clock Pin (11)

For $\pm 5\text{V}$ supplies the logic threshold level is 1.4V . For $\pm 8\text{V}$ and 0V to 5V supplies the logic threshold levels are 2.4V and 3V respectively. The logic threshold levels vary $\pm 100\text{mV}$ over the full military temperature range. The recommended duty cycle of the input clock is 50% although for clock frequencies below 500kHz the clock "on" time can be as low as 200ns . The maximum clock frequency for $\pm 5\text{V}$ supplies is 4MHz . For $\pm 7\text{V}$ supplies and above, the maximum clock frequency is 5MHz . Do not allow the clock levels to exceed the power supplies. For single supply operation and for $V_S \geq 6\text{V}$, $T^2\text{L}$ clock signals can be accommodated through level shifting, Figure 3.

Analog Ground Pins (3, 5)

For dual supply operation these pins should be connected to a ground plane. For single supply operation both pins should be tied to one half supply, Figure 2.

Connection Pins (7, 14)

A very short connection between pins 14 and 7 is recommended. This connection should be preferably done under the IC package. In a breadboard, use a one inch, or less, shielded coaxial cable; the shield should be grounded. In a PC board, use a one inch trace or less; surround the trace by a ground plane.

NC Pin (8)

Pin 8 is not internally connected, it should be preferably grounded.

Input, Output Pins (2, 9)

The input pin 2 is connected to a $12\text{k}\Omega$ resistor tied to the inverting input of an op amp. Pin 2 is protected against static discharge. The device's output, pin 9, is the output of an op amp which can typically source/sink $3/1\text{mA}$. Although the internal op amps are unity gain stable, driving long coax cables is not recommended.

When testing the device for noise and distortion, the output, pin 9, should be buffered, Figure 4. **The op amp power supply wire (or trace) should be connected directly to the power source.** To eliminate any output clock feedthrough, pin 9 should be buffered with a simple R, C lowpass filter, Figure 5. The cutoff frequency of the output filter should be $f_{\text{CLK}}/3$.

50/100 Ratio Pin (10)

For an f_{CLK}/f_c ratio of 50:1, pin 10 should be tied to V^+ . For an $f_{\text{CLK}}/f_{-3\text{dB}}$ ratio of 100:1, pin 10 should be tied to V^- . When pin 10 is at mid-supplies (i.e. ground), the filter response is neither Cauer nor transitional. Table 6 illustrates this response. Bypassing pin 10 with a $0.1\mu\text{F}$ capacitor reduces the, already small, clock feedthrough.

Compensation Pins (6, 7 and 1, 13)

To obtain a Cauer response with minimum passband ripple and cutoff frequencies above 20kHz , compensating components are required. Figure 6 uses $\pm 7.5\text{V}$ power supplies and compensation components to achieve up to 40kHz sweepable cutoff frequencies and $\pm 0.1\text{dB}$ passband ripple. Table 7 lists the typical amplitude response of Figure 6. Figure 7 illustrates the compensation scheme required to obtain a 100kHz cutoff frequency; Graph 4 and Tables 8 and 9 list the typical response of Figure 7 for 25°C and 125°C ambient temperature. As shown the ripple increases at high temperatures but still a $\pm 0.25\text{dB}$ figure can be obtained for ambient temperatures below 70°C .

PIN DESCRIPTION

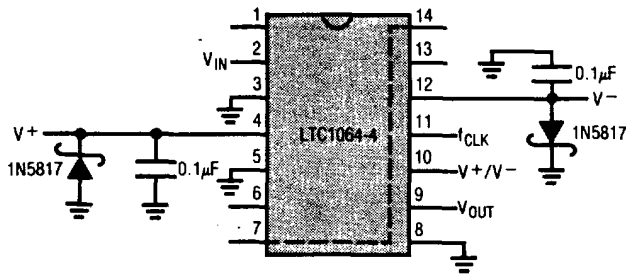

Figure 1. Using Schottky Diodes to Protect the IC from Power Supply Spikes.

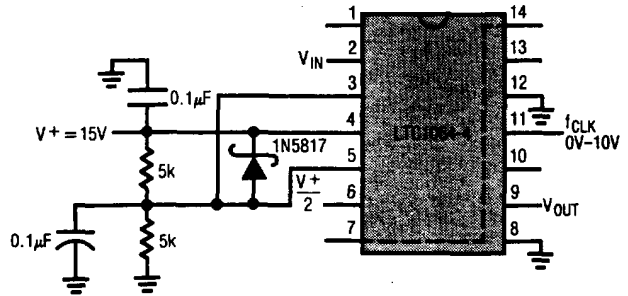

Figure 2. Single Supply Operation. If Fast Power Up or Down Transients are Expected, Use a 1N5817 Schottky Diode Between Pins 4 and 5.

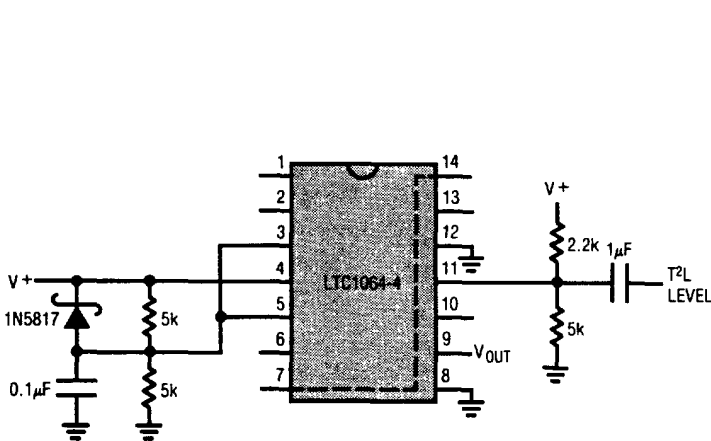
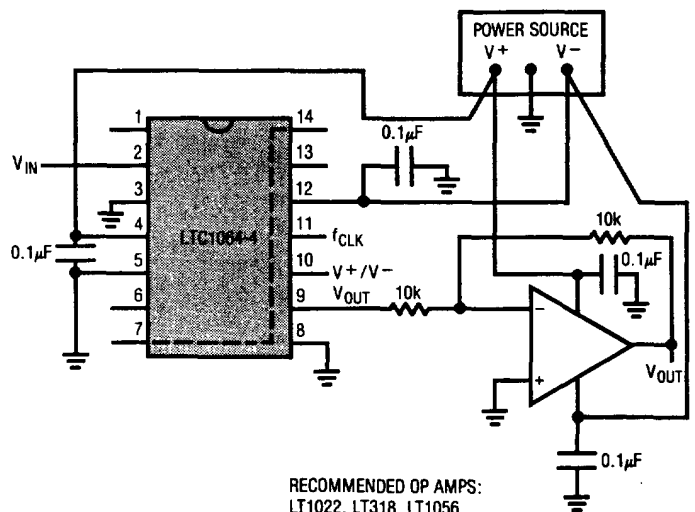

Figure 3. Level Shifting the Input T²L Clock for Single Supply Operation ≥ 6V.



RECOMMENDED OP AMPS:
LT1022, LT318, LT1056

Figure 4. Buffering the Filter Output. The Buffer Op Amp Should Not Share the LTC1064-4 Power Lines.

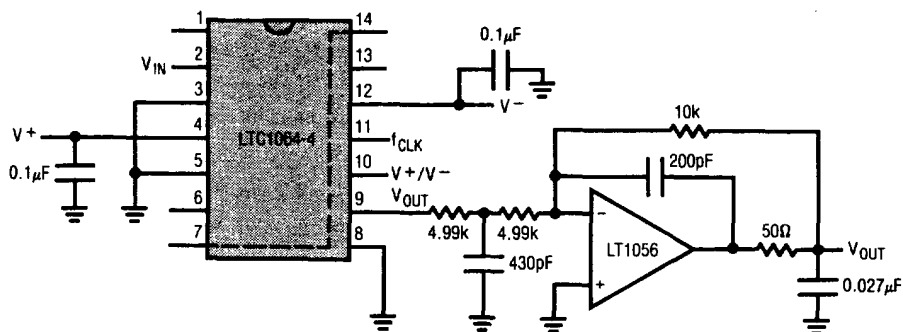

Figure 5. Adding an Output Buffer-Filter to Eliminate Any Clock Feedthrough. Passband Error of Output Buffer is ± 0.1dB to 50kHz, -3dB at 94kHz.

PIN DESCRIPTION

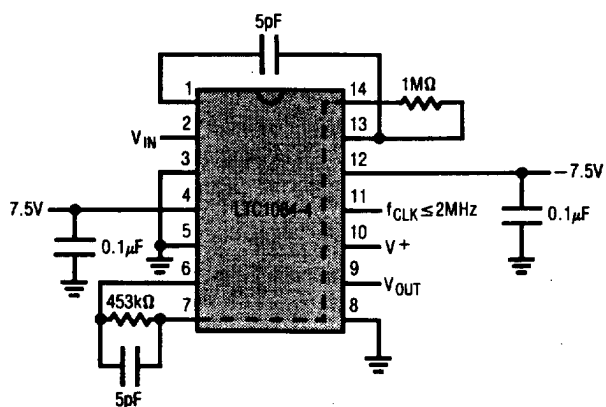

Figure 6. Compensating LTC1064-4 for Passband Ripple of $\pm 0.1\text{dB}$ and f_{CUTOFF} Sweeps to 40kHz.

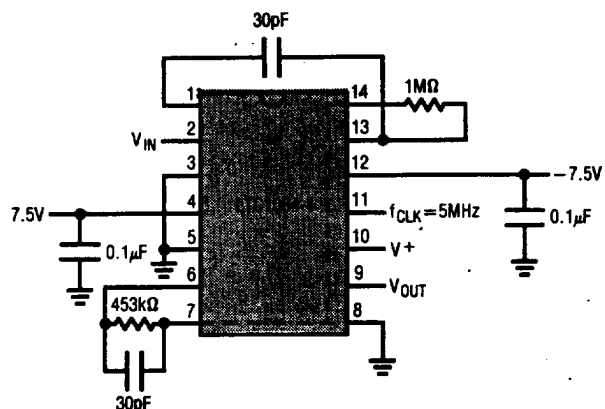

Figure 7. Compensating LTC1064-4 for $f_{\text{CUTOFF}} = 100\text{kHz}$, Gain at $f_{\text{CUTOFF}} \approx -1.3\text{dB}$, Table 8.