

## FEATURES

- Lowpass Filter with No DC Error
- Low Passband Noise
- Operates DC to 20kHz
- Operates on a Single 5V Supply or Up to  $\pm 8V$
- 5th Order Filter
- Maximally Flat Response
- Internal or External Clock
- Cascadable for Faster Rolloff
- Buffer Available
- 8 Pin DIP Package

## APPLICATIONS

- 60Hz Lowpass Filters
- Anti-Aliasing Filter
- Low Level Filtering
- Rolling Off AC Signals from High DC Voltages
- Digital Voltmeters
- Scales
- Strain Gauges

## DESCRIPTION

The LTC1062 is a 5th order all pole maximally flat lowpass filter with no DC error. Its unusual architecture puts the filter outside the DC path so DC offset and low frequency noise problems are eliminated. This makes the LTC1062 very useful for lowpass filters where DC accuracy is important.

The filter input and output are simultaneously taken across an external resistor. The LTC1062 is coupled to the signal through an external capacitor. This R,C reacts with the internal switched capacitor network to form a 5th order rolloff at the output.

The filter cutoff frequency is set by an internal clock which can be externally driven. The clock to cutoff frequency ratio is typically 100:1, allowing the clock ripple to be easily removed.

Two LTC1062s can be cascaded to form a 10th order quasi max flat lowpass filter. The device can be operated with single or dual supplies ranging from  $\pm 2.5V$  to  $\pm 9V$ .

The LTC1062 is manufactured using Linear Technology's enhanced LTCMOS™ silicon gate process.

LTCMOS™ is a trademark of Linear Technology Corp.

8

## TYPICAL APPLICATION

10Hz 5th Order Butterworth Lowpass Filter

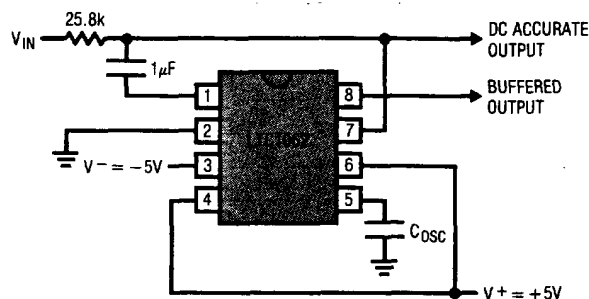

NOTE: TO ADJUST OSCILLATOR FREQUENCY, USE A 6800pF CAPACITOR IN SERIES WITH A 50K POT FROM PIN 5 TO GROUND.

Filter Amplitude Response and Noise

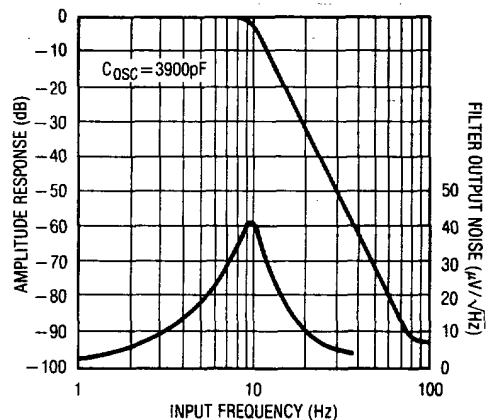

# LTC1062

## ABSOLUTE MAXIMUM RATINGS

Total Supply Voltage ( $V^+$  to  $V^-$ ) ..... 18V  
 Input Voltage at Any Pin .....  $V^- - 0.3V \leq V_{IN} \leq V^+ + 0.3V$   
 Lead Temperature (Soldering, 10 sec) ..... 300°C

Operating Temperature Range

LTC1062M .....  $-55^\circ\text{C} \leq T_A \leq 125^\circ\text{C}$

LTC1062C .....  $-40^\circ\text{C} \leq T_A \leq 85^\circ\text{C}$

Storage Temperature Range .....  $-65^\circ\text{C}$  to  $150^\circ\text{C}$

## PACKAGE/ORDER INFORMATION

TOP VIEW	ORDER PART NUMBER	TOP VIEW	ORDER PART NUMBER
<p>J8 PACKAGE 8-LEAD HERMETIC DIP</p> <p>N8 PACKAGE 8-LEAD PLASTIC DIP</p> <p><math>T_{JMAX} = 150^\circ\text{C}</math>, <math>\theta_{JA} = 100^\circ\text{C/W}</math> (J)  <math>T_{JMAX} = 100^\circ\text{C}</math>, <math>\theta_{JA} = 130^\circ\text{C/W}</math> (N)</p>	<p>LTC1062MJ8 LTC1062CJ8 LTC1062CN8</p>	<p>S PACKAGE 16-LEAD PLASTIC SOL</p> <p><math>T_{JMAX} = 150^\circ\text{C}</math>, <math>\theta_{JA} = 90^\circ\text{C/W}</math></p>	<p>LTC1062CS</p> <p>PART MARKING</p> <p>LTC1062CS</p>

Consult factory for industrial grade parts.

## ELECTRICAL CHARACTERISTICS

Test Conditions:  $V^+ = 5V$ ,  $V^- = -5V$ ,  $T_A = 25^\circ\text{C}$  unless otherwise specified, AC output measured at pin 7, Figure 1.

PARAMETER	CONDITIONS	MIN	TYP	MAX	UNITS
Power Supply Current	$C_{OSC}$ (Pin 5 to $V^-$ , Pin 11 in S16) = 100pF		4.5	7 10	mA mA
Input Frequency Range			0k - 20k		Hz
Filter Gain at $f_{IN} = 0$	$f_{CLK} = 100\text{kHz}$ , Pin 4, (Pin 6 in S16) at $V^+$ $C = 0.01\mu\text{F}$ , $R = 25.78\text{k}$		0.00		dB
$f_{IN} = 0.5f_C$ (Note 1)			-0.02	-0.3	dB
$f_{IN} = f_C$		-2	-3.00		dB
$f_{IN} = 2f_C$		-28	-30.00		dB
$f_{IN} = 4f_C$		-52	-60.00		dB
Clock to Cutoff Frequency Ratio, $f_{CLK}/f_C$	Same as above		100 $\pm$ 1		%
Filter Gain at $f_{IN} = 16\text{kHz}$	$f_{CLK} = 400\text{kHz}$ , Pin 4 at $V^+$ $C = 0.01\mu\text{F}$ , $R = 6.5\text{k}$	-45	-52		dB
$f_{CLK}/f_C$ Tempco	Same as above		10		ppm/ $^\circ\text{C}$
Filter Output (Pin 7, Pin 13 in S16) DC Swing	Pin 7 buffered with an external op amp	$\pm 3.5$	$\pm 3.8$		V
Clock Feedthrough			1		mV <sub>p-p</sub>
<b>Internal Buffer</b>					
Bias Current			2	50	pA
Bias Current			170	1000	pA
Offset Voltage			2	20	mV
Voltage Swing	$R_{LOAD} = 20\text{k}$	$\pm 3.5$	$\pm 3.8$		V
Short-Circuit Current Source/Sink			40/3		mA

## ELECTRICAL CHARACTERISTICS

Test Conditions:  $V^+ = 5V$ ,  $V^- = -5V$ ,  $T_A = 25^\circ C$  unless otherwise specified, AC output measured at pin 7, Figure 1.

PARAMETER	CONDITIONS	MIN	TYP	MAX	UNITS
<b>Clock (Note 3)</b>					
Internal Oscillator Frequency	$C_{OSC}$ (Pin 5 to $V^-$ , Pin 11 in S16) = 100pF	25	32	50	kHz
	$C_{OSC}$ (Pin 5 to $V^-$ , Pin 11 in S16) = 100pF ●	15		65	kHz
Max Clock Frequency			4		MHz
Pin 5 (Pin 11 in S16) Source or Sink Current		●	40	80	$\mu A$

The ● denotes specifications which apply over the full operating temperature range.

**Note 1:**  $f_c$  is the frequency where the gain is -3dB with respect to the input signal.

**Note 2:** The LTC1062M operates from  $-55^\circ C \leq T_A \leq 125^\circ C$ , the LTC1062C operates from  $-40^\circ C \leq T_A \leq 85^\circ C$ .

**Note 3:** The external or driven clock frequency is divided by either 1, 2, or 4 depending upon the voltage at pin 4. For the J8, N8 package, when pin 4 =  $V^+$ , ratio = 1; when pin 4 = GND, ratio = 2; when pin 4 =  $V^-$ , ratio = 4.

## BLOCK DIAGRAM (J8 or N8 package)

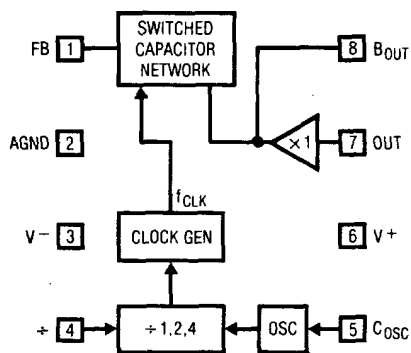

BY CONNECTING PIN 4 TO  $V^+$ , AGND, OR  $V^-$ , THE OUTPUT FREQUENCY OF THE INTERNAL CLOCK GENERATOR IS THE OSCILLATOR FREQUENCY DIVIDED BY 1, 2, 4. THE ( $f_{CLK}/f_c$ ) RATIO OF 100:1 IS WITH RESPECT TO THE INTERNAL CLOCK GENERATOR OUTPUT FREQUENCY. PIN 5 CAN BE DRIVEN WITH AN EXTERNAL CMOS LEVEL CLOCK. THE LTC1062 CAN ALSO BE SELF-CLOCKED BY CONNECTING AN EXTERNAL CAPACITOR ( $C_{OSC}$ ) TO GROUND (OR TO  $V^-$  IF  $C_{OSC}$  IS POLARIZED). UNDER THIS CONDITION AND WITH  $\pm 5V$  SUPPLIES, THE INTERNAL OSCILLATOR FREQUENCY IS:

$$f_{OSC} = 140kHz [33pF / (33pF + C_{OSC})]$$

For Adjusting Oscillator Frequency, Insert a 50K Pot in Series with  $C_{OSC}$ . Use Two Times Calculated  $C_{OSC}$ .

## AC TEST CIRCUIT

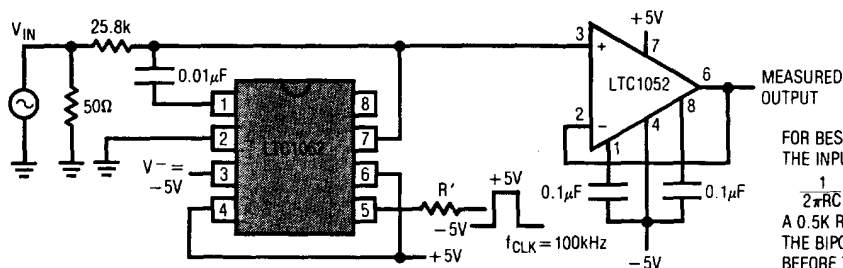

FOR BEST MAX. FLAT APPROXIMATION. THE INPUT R,C SHOULD BE SUCH AS:

$$\frac{1}{2\pi RC} = \frac{f_{CLK}}{100} \times 1.63$$

A 0.5K RESISTOR,  $R'$ , SHOULD BE USED IF THE BIPOLAR EXTERNAL CLOCK IS APPLIED BEFORE THE POWER SUPPLIES TURN ON.

Figure 1.

# TYPICAL PERFORMANCE CHARACTERISTICS

Amplitude Response Normalized to the Cutoff Frequency

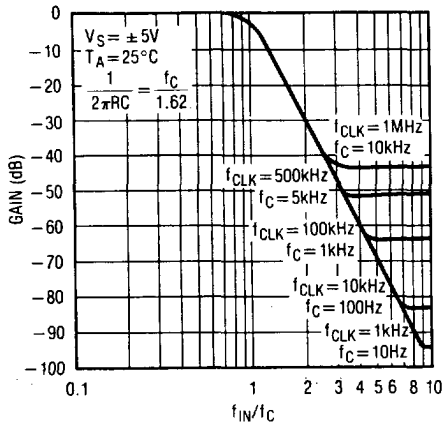

Amplitude Response Normalized to the Cutoff Frequency

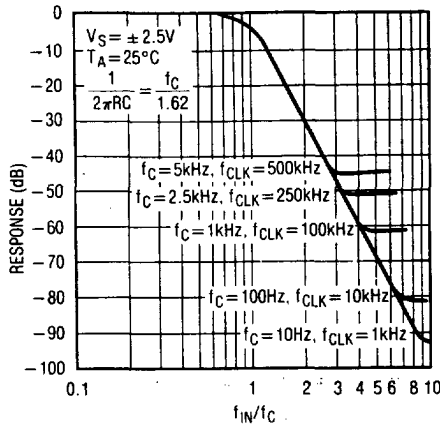

Passband Gain vs Input Frequency

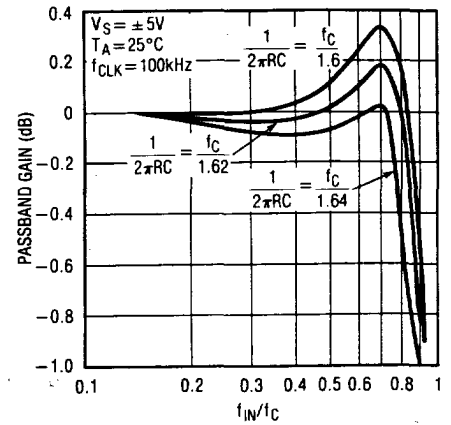

Passband Gain vs Input Frequency

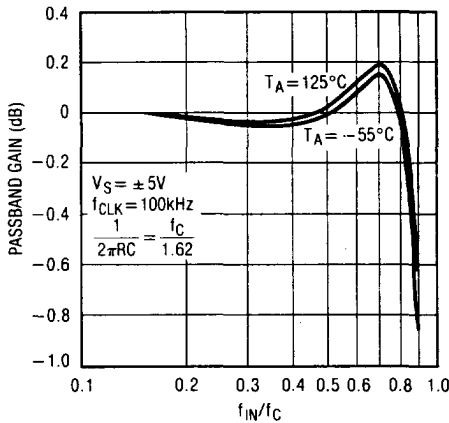

Passband Phase Shift vs Input Frequency

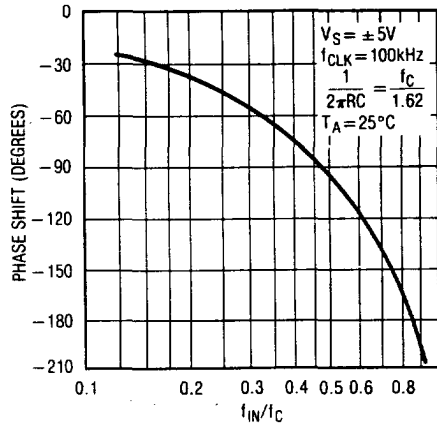

Filter Noise Spectral Density

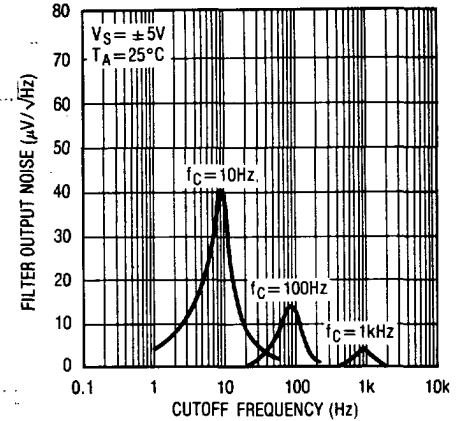

Normalized Oscillator Frequency, f\_osc vs Supply Voltage

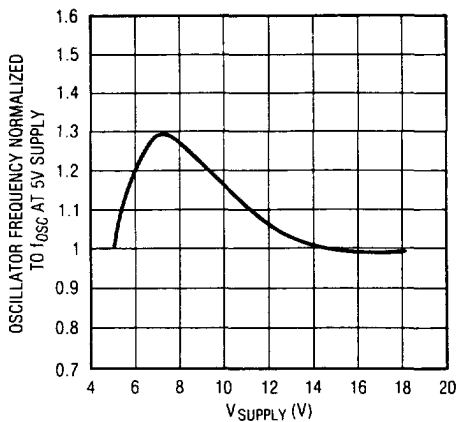

Oscillator Frequency, f\_osc vs Ambient Temperature

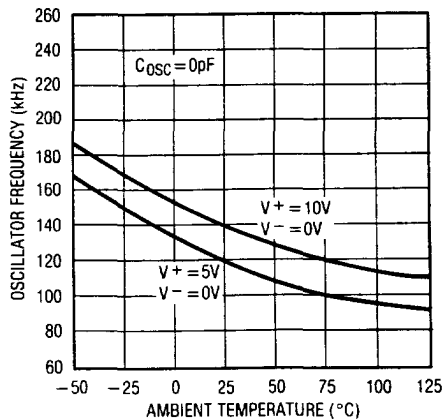

Power Supply Current vs Power Supply Voltage

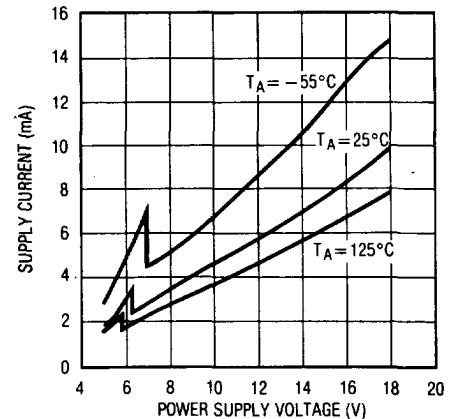

## APPLICATIONS INFORMATION

### Filter Input Voltage Range

Every node of the LTC1062 typically swings within 1V of either voltage supply, positive or negative. With the appropriate external (R,C) values, the amplitude response of all the internal or external nodes does not exceed a gain of 0 dB with the exception of pin 1. The amplitude response of the feedback node (pin 1) is shown in Figure 2. For an input frequency around  $0.8 \times f_c$ , the gain is 1.7 V/V and, with  $\pm 5V$  supplies, the peak-to-peak input voltage should not exceed 4.7V. If the input voltage goes beyond this value, clipping and distortion of the output waveform occur, but the filter will not get damaged nor will it oscillate. Also, the absolute maximum input voltage should not exceed the power supplies.

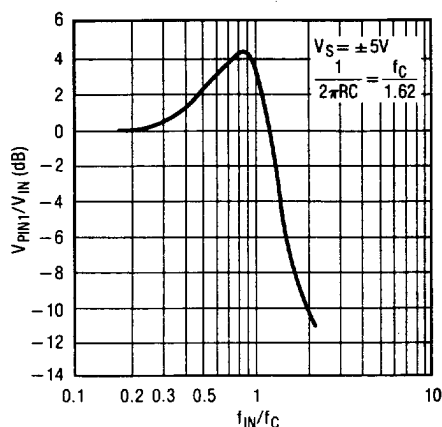

Figure 2. Amplitude Response of Pin 1

### Internal Buffer

The internal buffer out (pin 8) and pin 1 are part of the signal AC path. Excessive capacitive loading will cause gain errors in the passband, especially around the cutoff frequency. The internal buffer gain at DC is typically 0.006dB. The internal buffer output can be used as a filter output, however it has a few millivolts of DC offset. The temperature coefficient of the internal buffer is typically  $1\mu V/^\circ C$ .

### Filter Attenuation

The LTC1062 rolloff is typically 30dB/octave. When the clock, and the cutoff frequencies increase, the filter's maximum attenuation decreases. This is shown in the Typical Performance Characteristics. The decrease of the maximum attenuation, is due to the roll off at higher frequencies of the loop gains of the various internal feedback paths and not to the increase of the noise floor. For instance, for a 100kHz clock and 1kHz cutoff frequency, the maximum attenuation is about 64dB. A 4kHz, 1Vrms input signal will be predictably attenuated by 60dB at the output. A 6kHz, 1Vrms input signal will be attenuated by 64dB and not by 77dB as an ideal 5th order maximum flat filter would have dictated. The LTC1062 output at 6kHz will be about  $630\mu V_{rms}$ . The measured rms noise from DC to 17kHz was  $100\mu V_{rms}$  which is 16dB below the filter output.

### C<sub>OSC</sub>, Pin 5

The C<sub>OSC</sub>, pin 5, can be used with an external capacitor, C<sub>OSC</sub>, connected from pin 5 to ground. If C<sub>OSC</sub> is polarized it should be connected from pin 5 to the negative supply, pin 3. C<sub>OSC</sub> lowers the internal oscillator frequency. If pin 5 is floating, an internal 33pF capacitor plus the external interpin capacitance set the oscillator frequency around 140kHz with  $\pm 5V$  supply. An external C<sub>OSC</sub> will bring the oscillator frequency down by the ratio  $(33pF)/(33pF + C_{OSC})$ . The typical performance characteristics curves provide the necessary information to get the internal oscillator frequency for various power supply ranges. Pin 5 can also be driven with an external CMOS clock to override the internal oscillator. Although standard 7400 series CMOS gates do not guarantee CMOS levels with the current source and sink requirements of pin 5, they will, in reality, drive the C<sub>OSC</sub> pin. CMOS gates conforming to standard B series output drive have the appropriate voltage levels and more than enough output current to simultaneously drive several LTC1062 C<sub>OSC</sub> pins. The typical trip levels of the internal Schmitt trigger which input is pin 5, are given below.

V SUPPLY	V <sub>th+</sub>	V <sub>th-</sub>
±2.5V	+0.9V	-1V
±5V	+1.3V	-2.1V
±6V	+1.7V	-2.5V
±7V	+1.75V	-2.9V

## APPLICATIONS INFORMATION

### Divide By 1, 2, 4 (Pin 4)

By connecting pin 4 to V<sup>+</sup>, to mid supplies or to V<sup>-</sup>, the clock frequency driving the internal switched capacitor network is the oscillator frequency divided by 1, 2, 4, respectively. Note that the  $f_{CLK}/f_C$  ratio of 100:1 is with respect to the internal clock generator output frequency. The internal divider is useful for applications where octave tuning is required. The  $\pm 2$  threshold is typically  $\pm 1V$  from the mid supply voltage.

### Transient Response

Figure 3 shows the LTC1062 response to a 1V input step.

### Filter Noise

The filter wideband rms noise is typically  $100\mu V_{rms}$  for  $\pm 5V$  supply and it is nearly independent from the value of the cutoff frequency. For single 5V supply the rms noise is  $80\mu V_{rms}$ . Sixty-two percent of the wideband noise is in the passband, that is from DC to  $f_C$ . The noise spectral density, unlike conventional active filters, is nearly zero for frequencies below  $0.1 \times f_C$ . This is shown in the typical performance characteristics section. Table 1 shows the LTC1062 rms noise for different noise bandwidths.

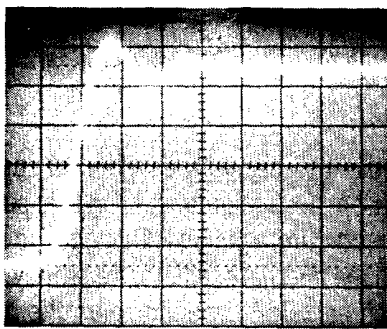

200mV/VERT DIV  
50ms/HORIZ DIV,  $f_C = 10Hz$   
5ms/HORIZ DIV,  $f_C = 100Hz$   
0.5ms/HORIZ DIV,  $f_C = 1kHz$

$$\frac{1}{2\pi RC} = \frac{f_C}{1.62}$$

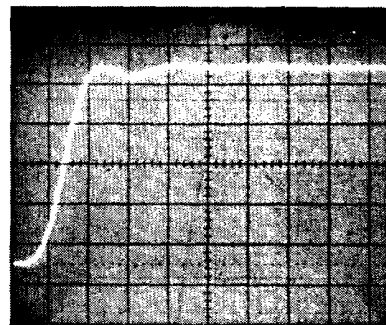

$$\frac{1}{2\pi RC} = \frac{f_C}{1.94}$$

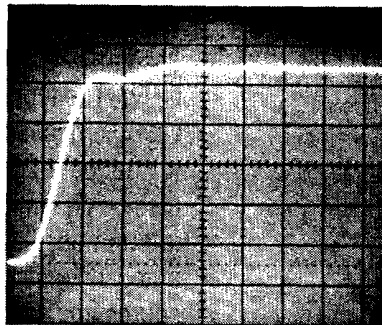

$$\frac{1}{2\pi RC} = \frac{f_C}{2.11}$$

Figure 3. Step Response to a 1V Peak Input Step

Table 1

NOISE BW	rms NOISE $V_S = \pm 5V$
DC - $0.1 \times f_C$	$2\mu V$
DC - $0.25 \times f_C$	$8\mu V$
DC - $0.5 \times f_C$	$20\mu V$
DC - $1 \times f_C$	$62\mu V$
DC - $2 \times f_C$	$100\mu V$

# TYPICAL APPLICATIONS

**AC Coupling an External CMOS Clock Powered from a Single Positive Supply, V+**

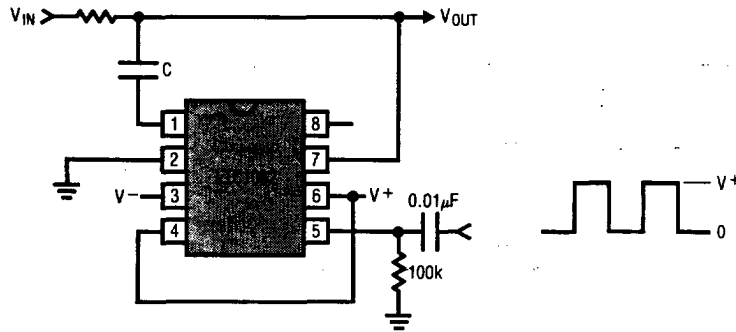

**Adding an External (R1, C1) to Eliminate the Clock Feedthrough and to Improve the High Frequency Attenuation Floor**

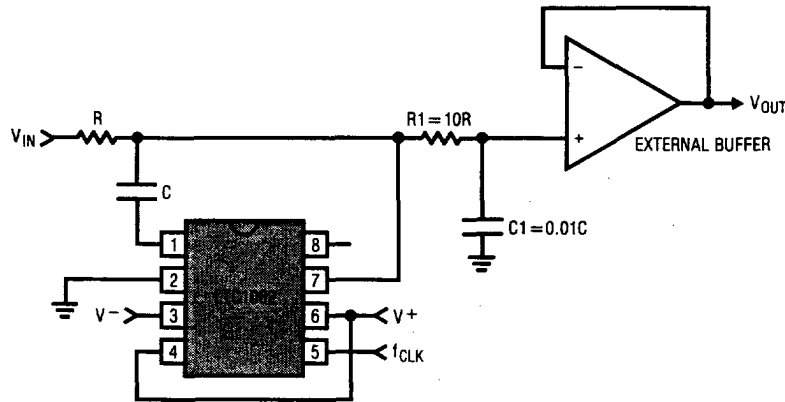

**Filtering AC Signals from High DC Voltages**

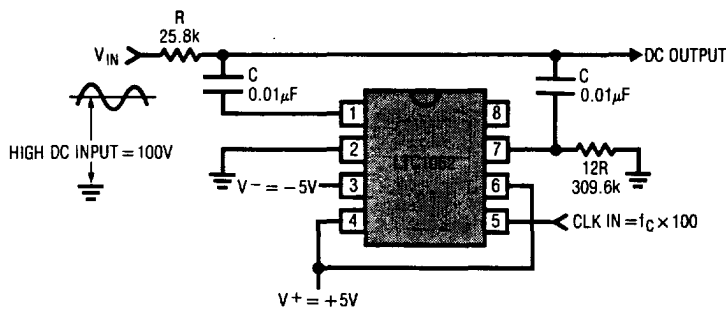

EX:  $f_{CLK} = 100kHz$ ,  $f_C = 1kHz$ . THE FILTER ACCURATELY PASSES THE HIGH DC INPUT AND ACTS AS 5th ORDER LP FILTER FOR THE AC SIGNALS RIDING ON THE DC.

**Passband Amplitude Response for the High DC Accurate 5th Order Filter**

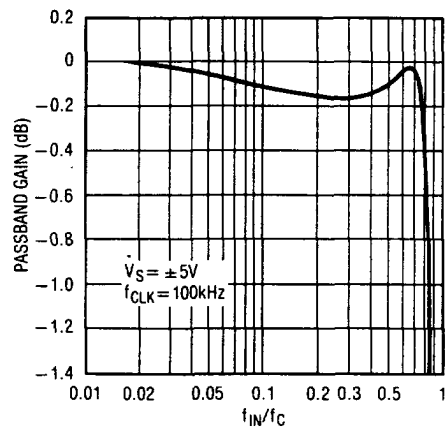

## TYPICAL APPLICATIONS

### Cascading Two LTC1062s to Form a Very Selective Clock Sweepable Bandpass Filter

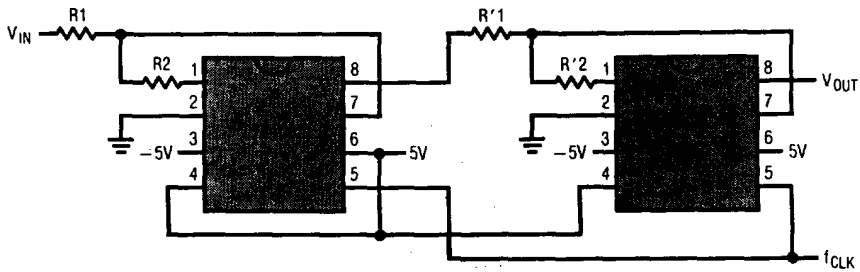

R1 = 10k, R2 = 10k  
R'1 = 10k, R'2 = 12.5k

### Clock Tunable Notch Filter

For simplicity use R3 = R4 = R5 = 10k;

$$\frac{R1}{R2} = 1.234, \frac{f_{CLK}}{f_{notch}} = \frac{79.3}{1}$$

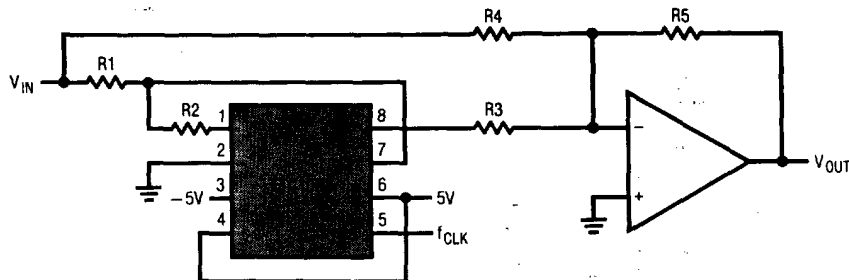

Frequency Response of the Bandpass Filter

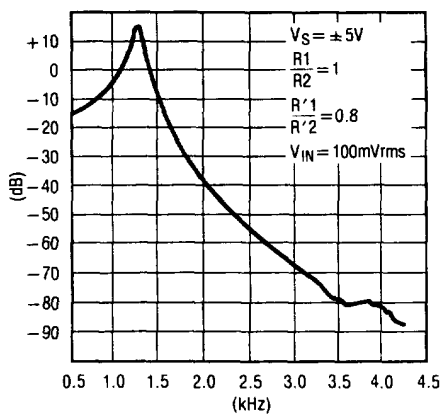

Frequency Response of the Notch Filter

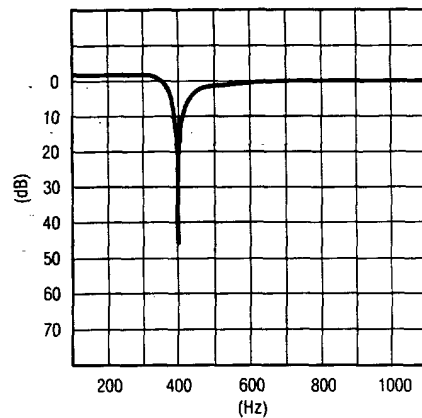



# TYPICAL APPLICATIONS

## Simple Cascading Technique

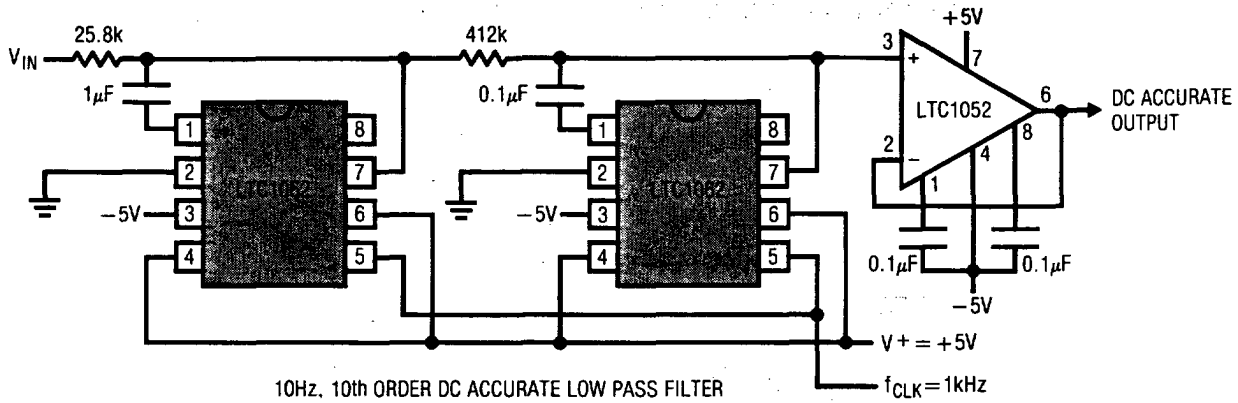

10Hz, 10th ORDER DC ACCURATE LOW PASS FILTER  
 60dB/OCTAVE ROLLOFF  
 0.5dB PASSBAND ERROR, 0dB DC GAIN  
 MAXIMUM ATTENUATION 110dB ( $f_{CLK} = 10kHz$ )  
 100dB ( $f_{CLK} = 1kHz$ )  
 95dB ( $f_{CLK} = 1MHz$ )

## 100Hz, 50Hz, 25Hz 5th Order DC Accurate LP Filter

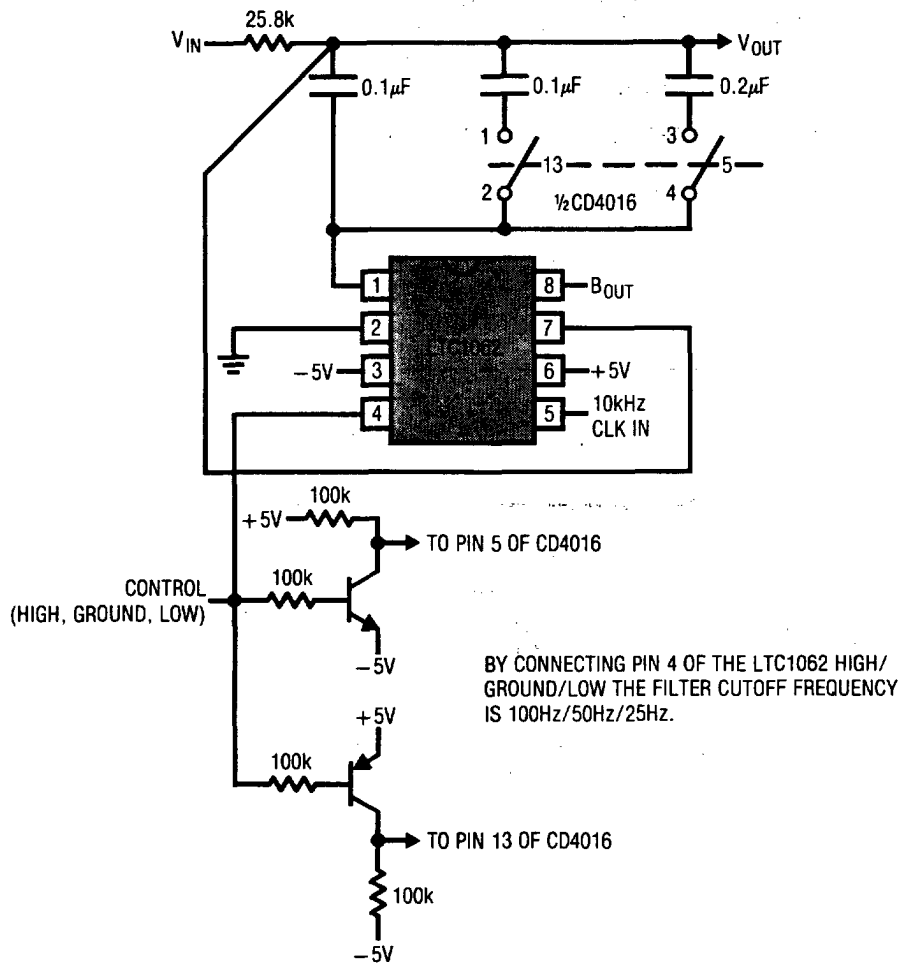

BY CONNECTING PIN 4 OF THE LTC1062 HIGH/ GROUND/LOW THE FILTER CUTOFF FREQUENCY IS 100Hz/50Hz/25Hz.

**TYPICAL APPLICATIONS**

**7th Order 100Hz Lowpass Filter with Continuous Output Filtering, Output Buffering and Gain Adjustment**

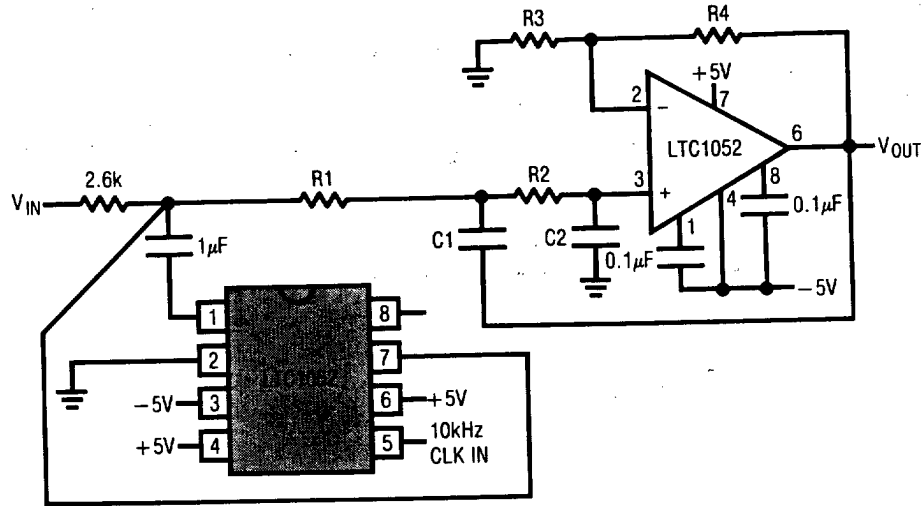

THE LTC1052 IS CONNECTED AS A 2<sup>ND</sup> ORDER SALLEN AND KEY LOWPASS FILTER WITH A CUTOFF FREQUENCY EQUAL TO THE CUTOFF FREQUENCY OF THE LTC1062. THE ADDITIONAL FILTERING ELIMINATES ANY 10kHz CLOCK FEED THROUGH PLUS DECREASES THE WIDEBAND NOISE OF THE FILTER.

DC OUTPUT OFFSET (REFERRED TO A DC GAIN OF UNITY) = 5μV MAX.

WIDEBAND NOISE (REFERRED TO A DC GAIN OF UNITY) = 60μVrms

OUTPUT FILTER COMPONENT VALUES						
DC GAIN	R3	R4	R1	R2	C1	C2
1	∞	0	14.3k	53.6k	0.1μF	0.033μF
10	3.57k	32.4k	46k	274k	0.01μF	0.02μF

**Single 5V Supply 5th Order LP Filter**

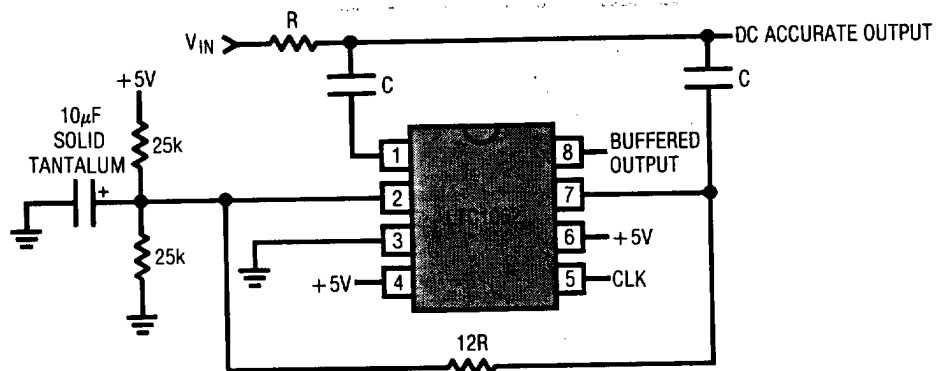

FOR A 10Hz FILTER R = 29.4k, C = 1μF, f<sub>CLK</sub> = 1kHz

THE FILTER IS MAXIMALLY FLAT FOR  $\frac{1}{2\pi RC} = \frac{f_c}{1.84}$

TYPICAL APPLICATIONS

A Lowpass Filter with a 60Hz Notch

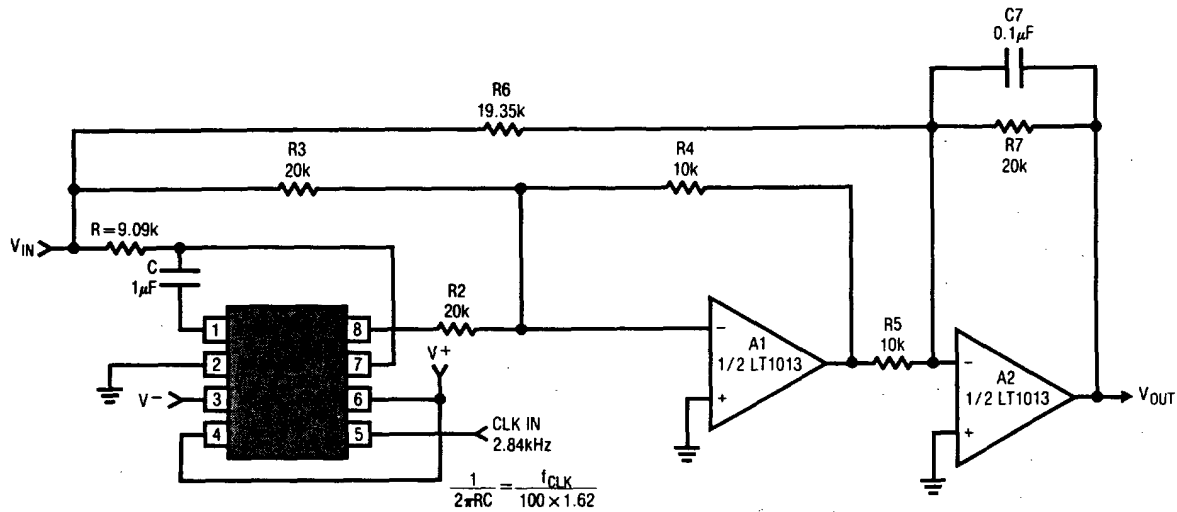

Frequency Response of the Above Lowpass Filter with the Notch  $f_{NOTCH} = \frac{f_{CLK}}{47.3}$

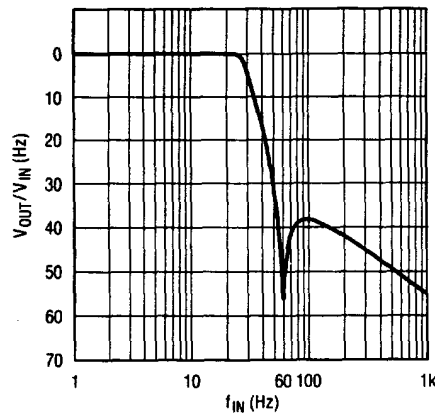

8

A Low Frequency, 5Hz Filter using Back-to-Back Solid Tantalum Capacitors

