

Single Switch Synchronous Forward Controller

FEATURES

- Synchronous Rectifier Control for High Efficiency
- Programmable Volt-Second Clamp
- Output Power Levels from 25W to 500W
- Low Current Start-Up
- True PWM Soft-Start
- Low Stress Short Circuit Protection
- Precision 100mV Current Limit Threshold
- Adjustable Delay for Synchronous Timing
- Accurate Shutdown Threshold with Programmable Hysteresis
- Programmable Slope Compensation
- Programmable Leading Edge Blanking
- Programmable Frequency (100kHz to 500kHz)
- Synchronizable to an External Clock up to $1.5 \cdot f_{OSC}$
- Internal 1.23V Reference
- 2.5V External Reference
- Current Mode Control
- Small 16-Pin SSOP Package

APPLICATIONS

- Telecommunications Power Supplies
- Industrial and Distributed Power
- Isolated and Non-Isolated DC/DC Converters

DESCRIPTION

The LT[®]1952 is a current mode PWM controller optimized to control the forward converter topology, using one primary MOSFET. The LT1952 provides synchronous rectifier control, resulting in extremely high efficiency. A programmable Volt-Second clamp provides a safeguard for transformer reset that prevents saturation. This allows a single MOSFET on the primary side to reliably run at greater than 50% duty cycle for high MOSFET, transformer and rectifier utilization. The LT1952 includes soft-start for controlled exit from shutdown, overcurrent conditions and undervoltage lockout. A precision 100mV current limit threshold, independent of duty cycle, combines with soft-start to provide hiccup short circuit protection. Micropower start-up allows the LT1952 to be efficiently started from high input voltages. Programmable slope compensation and leading edge blanking allow optimization of loop bandwidth with a wide range of inductors and MOSFETs. The LT1952 can be programmed over a 100kHz to 500kHz frequency range and the part can be synchronized to an external clock. The error amplifier is a true op amp, allowing a wide range of compensation networks. The LT1952 is available in a small 16-pin SSOP package.

LT, LTC and LT are registered trademarks of Linear Technology Corporation.

TYPICAL APPLICATION

36V to 72V Input, 12V at 20A Semi-Regulated Bus Converter

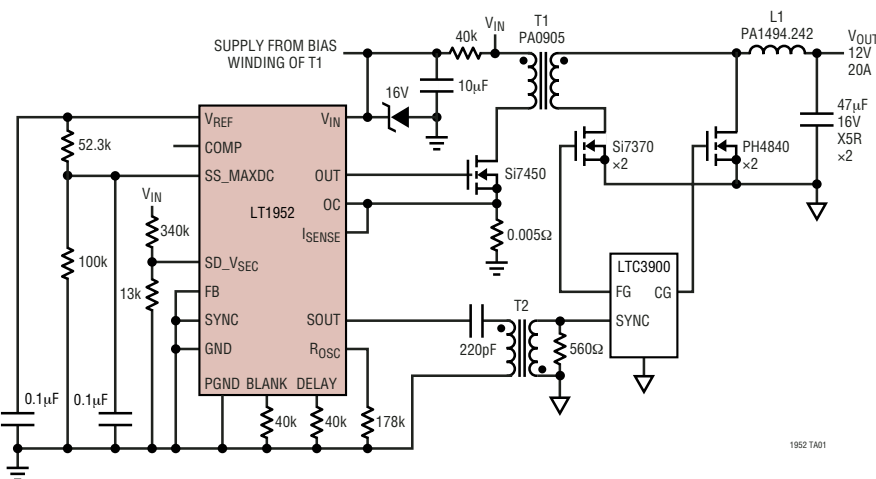

12V Bus Converter
 V_{OUT} vs V_{IN}

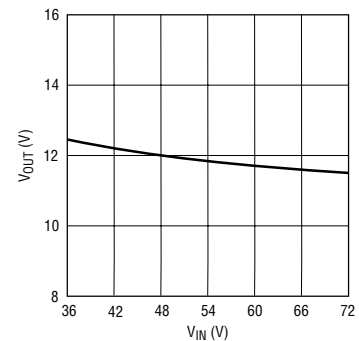

1952 TA01

1952 TA01b

ABSOLUTE MAXIMUM RATINGS

(Note 1)

V_{IN} (Note 8)	-0.3V to 25V
SYNC, SS_MAXDC, SD_VSEC, I _{SENSE} , OC, COMP, BLANK, DELAY	-0.3V to 6V
FB	-0.3V to 3V
R _{OSC}	-50 μ A
V _{REF}	-10mA
Operating Junction Temperature Range (Notes 2, 5)	-40°C to 125°C
Storage Temperature Range	-65°C to 150°C
Lead Temperature (Soldering, 10 sec)	300°C

PACKAGE/ORDER INFORMATION

<p>TOP VIEW</p> <p>GN PACKAGE 16-LEAD PLASTIC SSOP T_{JMAX} = 125°C, θ_{JA} = 110°C/W, θ_{JC} = 40°C/W</p>	ORDER PART NUMBER
	LT1952EGN LT1952IGN
	GN PART MARKING
	1952E 1952I

Consult LTC Marketing for parts specified with wider operating temperature ranges.

ELECTRICAL CHARACTERISTICS

The ● denotes the specifications which apply over the full operating temperature range, otherwise specifications are at T_A = 25°C. COMP = open, FB = 1.4V, R_{OSC} = 178k, SYNC = 0V, SS_MAXDC = V_{REF}, V_{REF} = 0.1 μ F, SD_VSEC = 2V, BLANK = 40k, DELAY = 40k, I_{SENSE} = 0V, OC = 0V, OUT = 1nF, V_{IN} = 15V, SOUT = open, unless otherwise specified.

PARAMETER	CONDITIONS	MIN	TYP	MAX	UNITS	
PWM CONTROLLER						
Operational Input Voltage	I _(VREF) = 0 μ A	● V _{IN OFF}		25	V	
V _{IN} Quiescent Current	I _(VREF) = 0 μ A, FB = 0V, I _{SENSE} = OC = Open		5.2	6.5	mA	
V _{IN} Startup Current	FB = 0V, SS_MAXDC = 0V (Notes 4, 9)	●	460	700	μ A	
V _{IN} Shutdown Current	SD_VSEC = 0V		240	350	μ A	
SD_VSEC Threshold	10V < V _{IN} < 25V	●	1.261	1.32	1.379	V
SD_VSEC (ON) Current	SD_VSEC = SD_VSEC Threshold + 100mV		0		μ A	
SD_VSEC (OFF) Current	SD_VSEC = SD_VSEC Threshold - 100mV		9.5	11.2	12.9	μ A
V _{IN ON}		●	12.75	14.25	15.75	V
V _{IN OFF}		●	8.0	8.75	9.25	V
V _{IN HYSTERESIS}		●	3.75	5.5	6.75	V
VREF						
Output Voltage	I _(VREF) = 0 μ A	●	2.425	2.5	2.575	V
Line Regulation	I _(VREF) = 0 μ A, 10V < V _{IN} < 25V			1	10	mV
Load Regulation	0 μ A < I _(VREF) < 2.5mA			1	10	mV
OSCILLATOR						
Frequency: f _{OSC}	R _{OSC} = 178k, FB = 1V	●	165	200	240	kHz
Minimum Programmable f _{OSC}	R _{OSC} = 365k		80	100	120	kHz
Maximum Programmable f _{OSC}	R _{OSC} = 64.9k, COMP = 2.5V, SD_VSEC = 2.64V		440	500	560	kHz
SYNC Input Resistance				18		k Ω
SYNC Switching Threshold	FB = 1V			1.5	2.2	V
SYNC Frequency/f _{osc}	FB = 1V (Note 7)			1.25	1.5	
f _{OSC} Line Reg	FB = 1V, R _{OSC} = 178k; 10V < V _{IN} < 25V, SS_MAXDC = 1.84V			0.05	0.33	%/V
V _{ROSC}	R _{OSC} Pin voltage			1		V

ELECTRICAL CHARACTERISTICS The ● denotes the specifications which apply over the full operating temperature range, otherwise specifications are at $T_A = 25^\circ\text{C}$. COMP = open, FB = 1.4V, $R_{\text{OSC}} = 178\text{k}$, SYNC = 0V, SS_MAXDC = V_{REF} , $V_{\text{REF}} = 0.1\mu\text{F}$, SD_VSEC = 2V, BLANK = 40k, DELAY = 40k, $I_{\text{SENSE}} = 0\text{V}$, OC = 0V, OUT = 1nF, $V_{\text{IN}} = 15\text{V}$, SOUT = open, unless otherwise specified.

PARAMETER	CONDITIONS	MIN	TYP	MAX	UNITS
ERROR AMPLIFIER					
FB Reference Voltage	$10\text{V} < V_{\text{IN}} < 25\text{V}$, $V_{\text{OL}} + 0.2\text{V} < \text{COMP} < V_{\text{OH}} - 0.2$	● 1.201	1.226	1.250	V
FB Input Bias Current	FB = FB Reference Voltage		-75	-200	nA
Open Loop Voltage Gain	$V_{\text{OL}} + 0.2\text{V} < \text{COMP} < V_{\text{OH}} - 0.2$	65	85		dB
Unity Gain Bandwidth	(Note 6)		3		MHz
COMP Source Current	FB = 1V, COMP = 1.6V	-4	-9		mA
COMP Sink Current	COMP = 1.6V	4	10		mA
COMP Current (Disabled)	FB = V_{REF} , COMP = 1.6V	18	23	28	μA
COMP High Level: V_{OH}	FB = 1V, $I_{(\text{COMP})} = -250\mu\text{A}$	2.7	3.2		V
COMP Active Threshold	FB = 1V, SOUT Duty Cycle > 0 %	0.7	1.0		V
COMP Low Level: V_{OL}	$I_{(\text{COMP})} = 250\mu\text{A}$		0.15	0.4	V
CURRENT SENSE					
I_{SENSE} Maximum Threshold	COMP = 2.5V, FB = 1V	197	220	243	mV
I_{SENSE} Input Current (Duty Cycle = 0%)	COMP = 2.5V, FB = 1V (Note 4)		-8		μA
I_{SENSE} Input Current (Duty Cycle = 80%)	COMP = 2.5V, FB = 1V (Note 4)		-35		μA
OC Threshold		● 98	107	116	mV
OC Input Current	(OC = 100mV)		-50	-100	nA
Default Blanking Time	COMP = 2.5V, FB = 1V (Note 10)		180		ns
Adjustable Blanking Time	COMP = 2.5V, FB = 1V, $R_{\text{BLANK}} = 120\text{k}$		540		ns
V_{BLANK}			1		V
SOUT DRIVER					
SOUT Clamp Voltage	$I_{(\text{GATE})} = 0\mu\text{A}$, COMP = 2.5V, FB = 1V	10.5	12	13.5	V
SOUT Low Level	$I_{(\text{GATE})} = 25\text{mA}$		0.5	0.75	V
SOUT High Level	$I_{(\text{GATE})} = -25\text{mA}$, $V_{\text{IN}} = 12\text{V}$, COMP = 2.5V, FB = 1V	10			V
SOUT Active Pull-Off in Shutdown	$V_{\text{IN}} = 5\text{V}$, SD_VSEC = 0V, SOUT = 1V	1			mA
SOUT to OUT (Rise) DELAY (t_{DELAY})	COMP = 2.5V, FB = 1V (Note 10) $R_{\text{DELAY}} = 120\text{k}$		40	120	ns
V_{DELAY}			0.9		V
OUT DRIVER					
OUT Rise Time	FB = 1V, CL = 1nF (Notes 3, 6)		50		ns
OUT Fall Time	FB = 1V, CL = 1nF (Notes 3, 6)		30		ns
OUT Clamp Voltage	$I_{(\text{GATE})} = 0\mu\text{A}$, COMP = 2.5V, FB = 1V	11.5	13	14.5	V
OUT Low Level	$I_{(\text{GATE})} = 20\text{mA}$ $I_{(\text{GATE})} = 200\text{mA}$		0.45	0.75	V
OUT High Level	$I_{(\text{GATE})} = -20\text{mA}$, $V_{\text{IN}} = 12\text{V}$, COMP = 2.5V, FB = 1V $I_{(\text{GATE})} = -200\text{mA}$, $V_{\text{IN}} = 12\text{V}$, COMP = 2.5V, FB = 1V	9.9			V
OUT Active Pull-Off in Shutdown	$V_{\text{IN}} = 5\text{V}$, SD_VSEC = 0V, OUT = 1V	20			mA

ELECTRICAL CHARACTERISTICS The ● denotes the specifications which apply over the full operating temperature range, otherwise specifications are at $T_A = 25^\circ\text{C}$. COMP = open, FB = 1.4V, $R_{OSC} = 178\text{k}$, SYNC = 0V, SS_MAXDC = V_{REF} , $V_{REF} = 0.1\mu\text{F}$, SD_VSEC = 2V, BLANK = 40k, DELAY = 40k, $I_{SENSE} = 0\text{V}$, OC = 0V, OUT = 1nF, $V_{IN} = 15\text{V}$, SOUT = open, unless otherwise specified.

PARAMETER	CONDITIONS	MIN	TYP	MAX	UNITS
OUT Max Duty Cycle	COMP = 2.5V, FB = 1V, $R_{DELAY} = 10\text{k}$ ($f_{OSC} = 200\text{kHz}$) SD_VSEC = 1.4V, SS_MAXDC = V_{REF}	83	90		%
OUT Max Duty Cycle Clamp	COMP = 2.5V, FB = 1V, $R_{DELAY} = 10\text{k}$ ($f_{OSC} = 200\text{kHz}$) SD_VSEC = 1.32V, SS_MAXDC = 1.84V SD_VSEC = 2.64V, SS_MAXDC = 1.84V	63.5 25	72 33	80.5 41	% %

SOFT-START

SS_MAXDC Low Level: V_{OL}	$I_{(SS_MAXDC)} = 150\mu\text{A}$, OC = 1V		0.2		V
SS_MAXDC Soft-Start Reset Threshold	Measured on SS_MAXDC		0.45		V
SS_MAXDC Active Threshold	FB = 1V, DC > 0%		0.8		V
SS_MAXDC Input Current (Soft-Start Pulldown: Idis)	SS_MAXDC = 1V, SD_VSEC = 1.4V, OC = 1V		800		μA

Note 1: Absolute Maximum Ratings are those values beyond which the life of a device may be impaired.

Note 2: The LT1952EGN is guaranteed to meet performance specifications from 0°C to 125°C junction temperature. Specifications over the -40°C to 125°C operating junction temperature range are assured by design, characterization and correlation with statistical process controls. The LT1952IGN is guaranteed over the full -40°C to 125°C operating junction temperature range.

Note 3: Rise and Fall times are measured at 10% and 90% levels.

Note 4: Guaranteed by correlation to static test.

Note 5: This IC includes over-temperature protection that is intended to protect the device during momentary overload conditions. Junction

temperature will exceed 125°C when over-temperature protection is active. Continuous operation above the specified maximum operating junction temperature may impair device reliability.

Note 6: Guaranteed but not tested.

Note 7: Maximum recommended SYNC frequency = 500kHz.

Note 8: In applications where the V_{IN} pin is supplied via an external RC network from a SYSTEM $V_{IN} > 25\text{V}$, an external zener with clamp voltage $V_{IN\text{ ON(MAX)}} < V_Z < 25\text{V}$ should be connected from the V_{IN} pin to ground.

Note 9: V_{IN} start-up current is measured at $V_{IN} = V_{IN\text{ ON}} - 0.25\text{V}$ and scaled by x 1.18 (to correlate to worst case V_{IN} start-up current at $V_{IN\text{ ON}}$).

Note 10: Timing for R = 40k derived from measurement with R = 240k.

TYPICAL PERFORMANCE CHARACTERISTICS

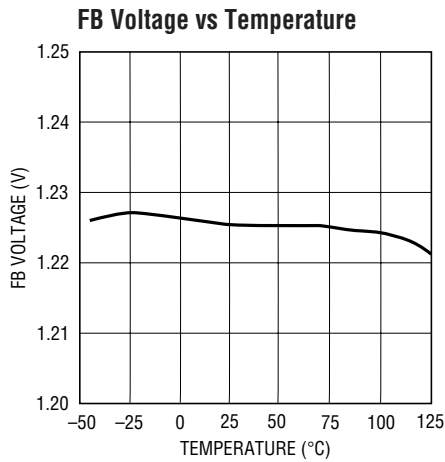

1952 G01

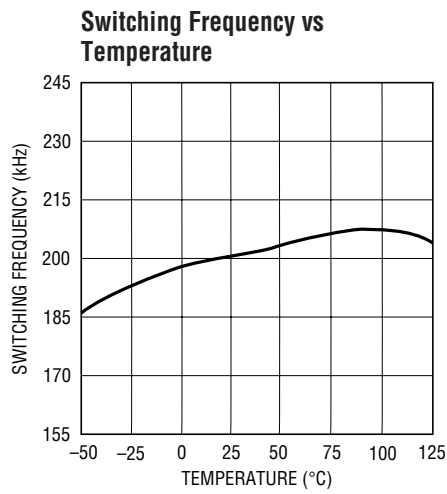

1952 G02

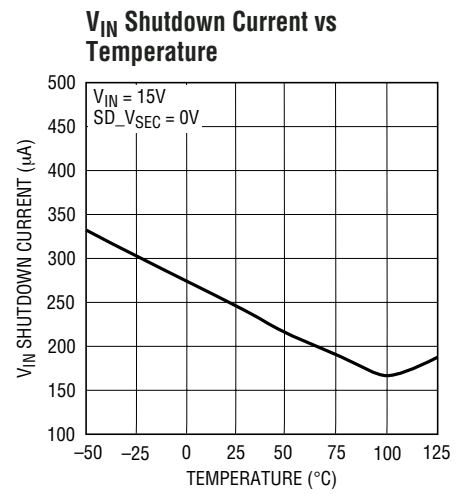

1952 G03

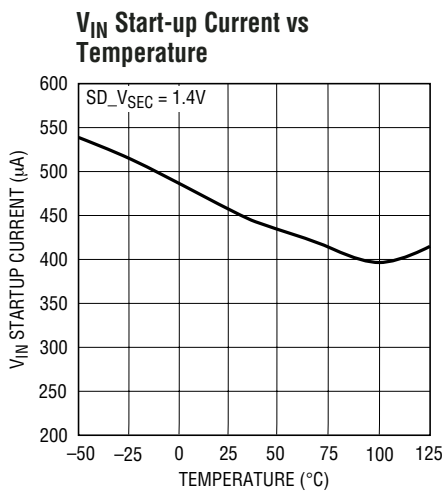

1952 G04

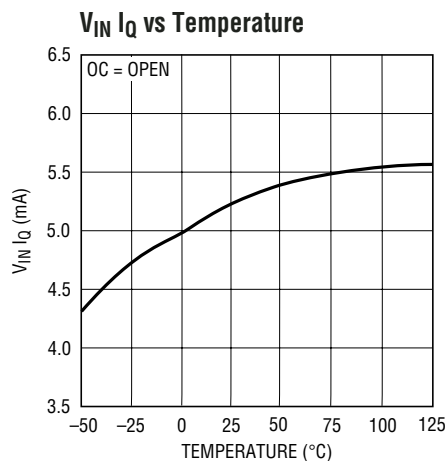

1952 G05

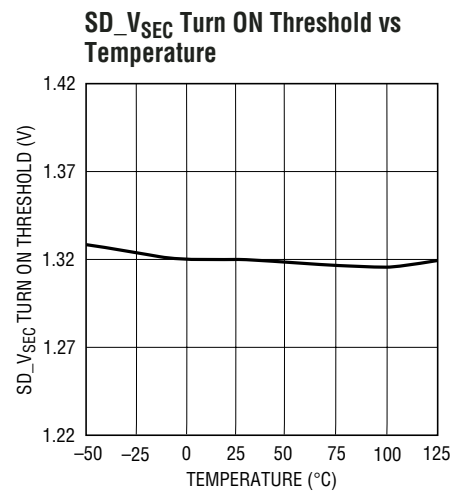

1952 G06

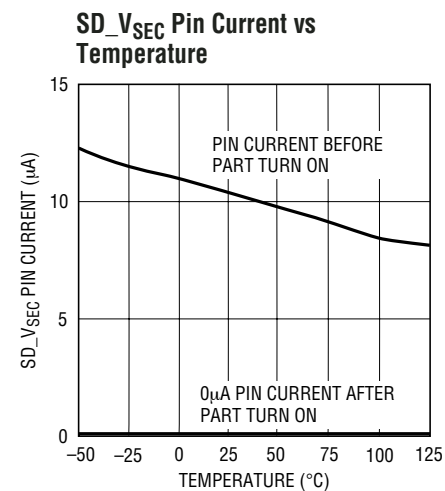

1952 G07

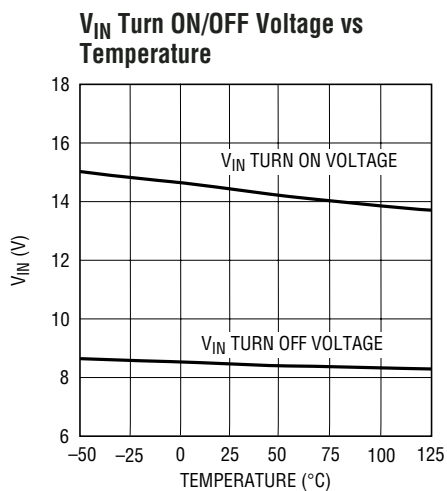

1952 G08

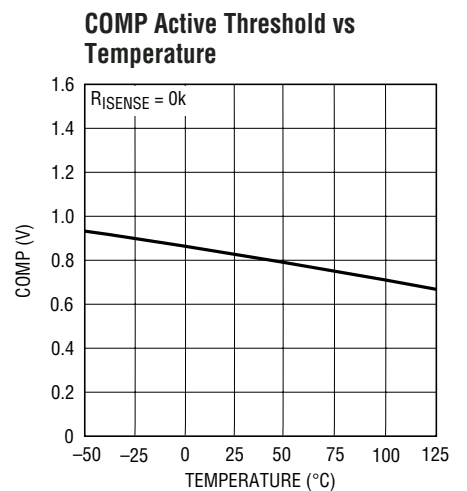

1952 G09

TYPICAL PERFORMANCE CHARACTERISTICS

COMP Source Current vs Temperature

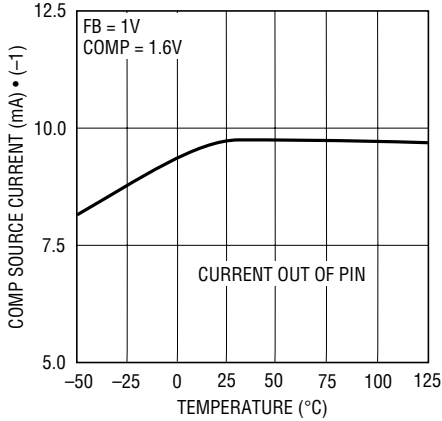

1952 G10

COMP Sink Current vs Temperature

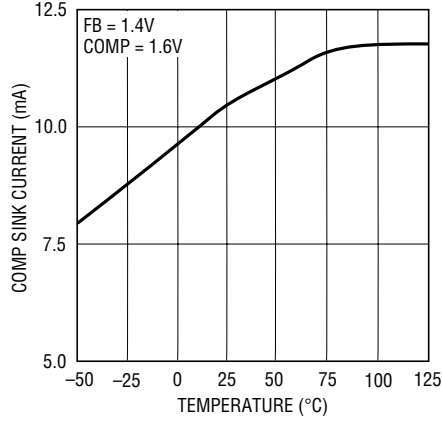

1952 G11

(Disabled) COMP Pin Current vs Temperature

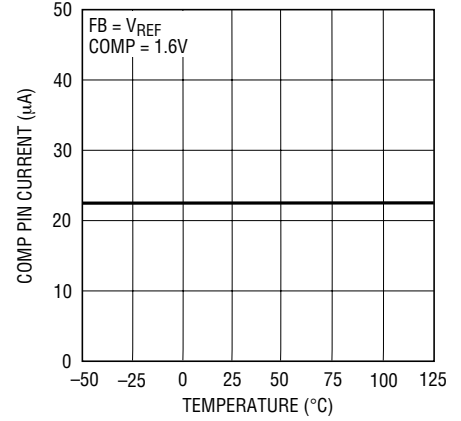

1952 G12

I_{SENSE} Maximum Threshold vs COMP

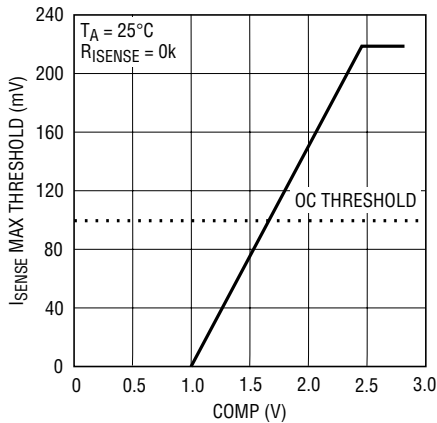

1952 G13

I_{SENSE} Maximum Threshold vs Temperature

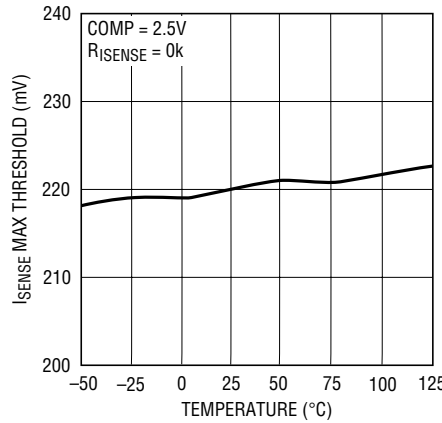

1952 G14

I_{SENSE} Pin Current (Out of Pin) vs Duty Cycle

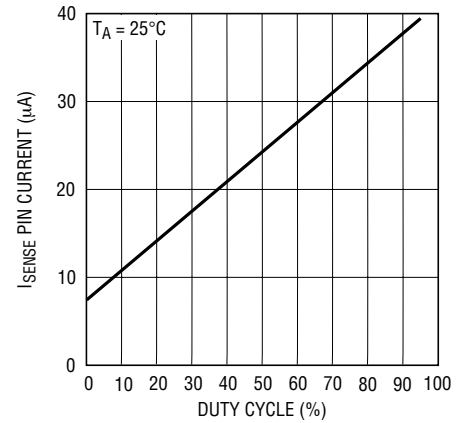

1952 G15

I_{SENSE} Maximum Threshold vs Duty Cycle (Programming Slope Compensation)

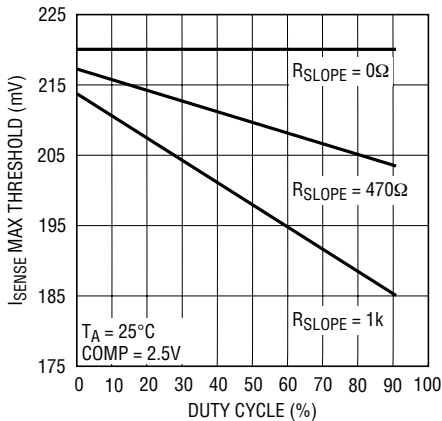

1952 G16

OC (Over-Current) Threshold vs Temperature

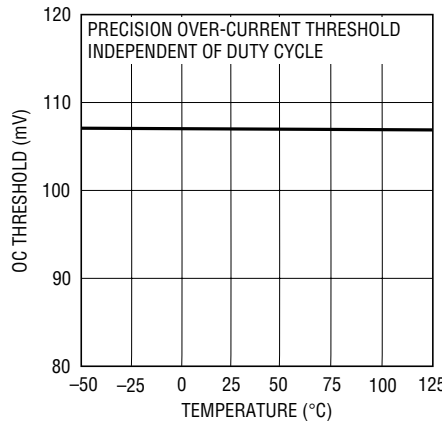

1952 G17

Blank Duration vs Temperature

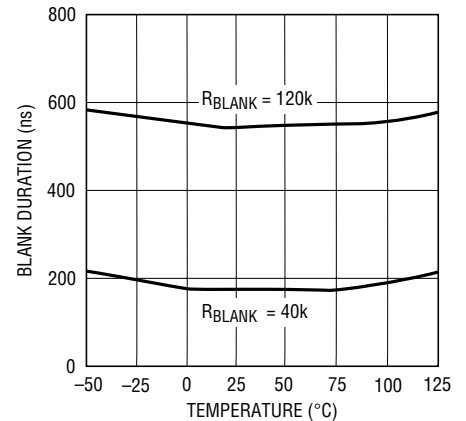

1952 G18



TYPICAL PERFORMANCE CHARACTERISTICS

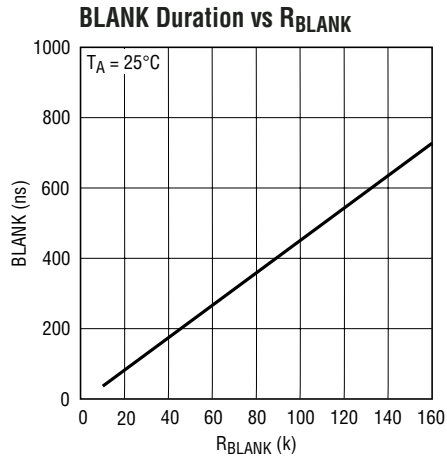

1952 G26

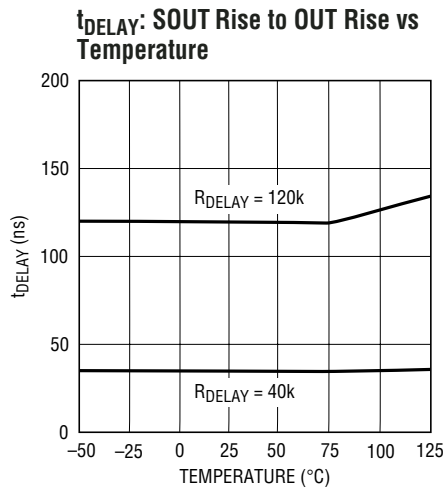

1952 G19

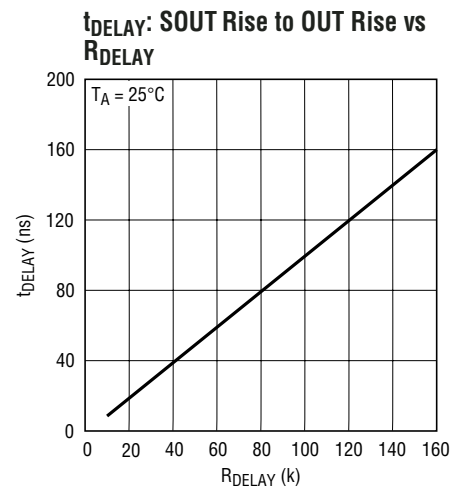

1952 G27

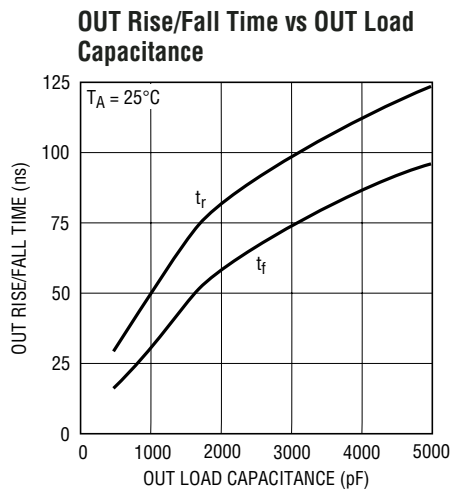

1952 G20

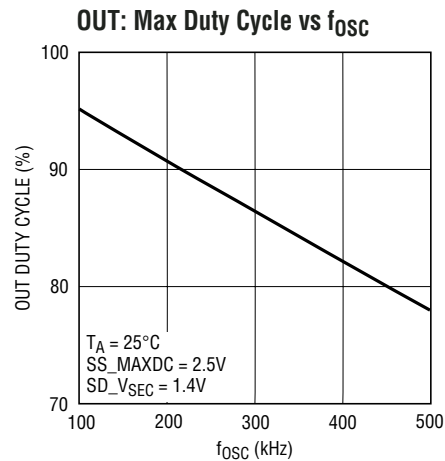

1952 G21

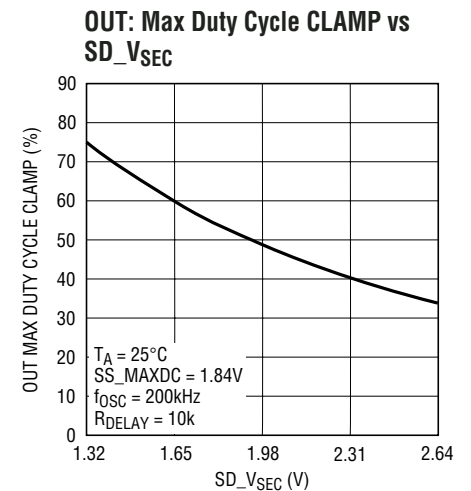

1952 G22

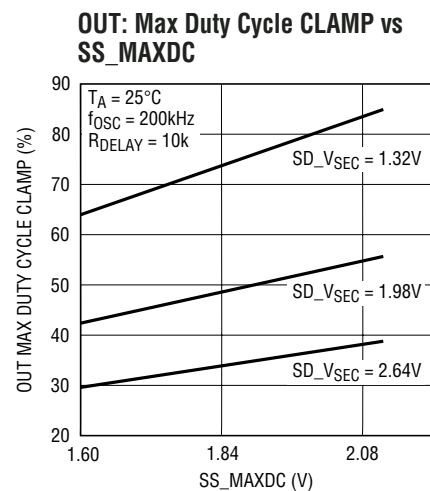

1952 G23

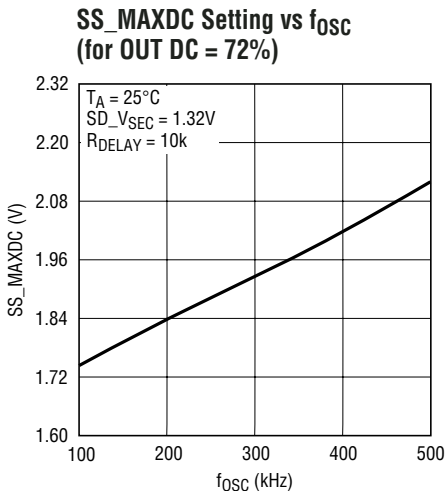

1952 G24

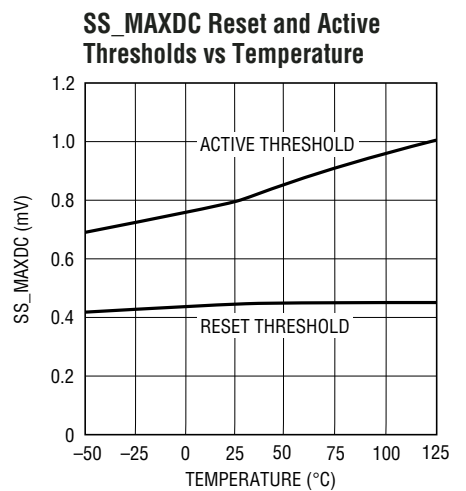

1952 G25

PIN FUNCTIONS

COMP (Pin 1): Output Pin of the Error Amplifier. The error amplifier is an op amp, allowing various compensation networks to be connected between the COMP pin and FB pin for optimum transient response. The voltage on this pin corresponds to the peak current of the external FET. Full operating voltage range is between 0.8V and 2.5V corresponding to 0mV to 220mV at the I_{SENSE} pin. For applications using the 100mV OC pin for over-current detection, typical operating range for the COMP pin is 0.8V to 1.6V. For isolated applications where COMP is controlled by an opto-coupler, the COMP pin output drive can be disabled with $FB = V_{REF}$, reducing the COMP pin current to $(COMP - 0.7)/40k$.

FB (Pin 2): Monitors the output voltage via an external resistor divider and is compared with an internal 1.23V reference by the error amplifier. FB connected to V_{REF} disables error amplifier output.

R_{OSC} (Pin 3): A resistor to ground programs the operating frequency of the IC between 100kHz and 500kHz. Nominal voltage on the R_{OSC} pin is 1.0V.

SYNC (Pin 4): Used to Synchronize the Internal Oscillator to an External Signal. It is directly logic compatible and can be driven with any signal between 10% and 90% duty cycle. If unused, the pin can be left open or connected to ground.

SS_MAXDC (Pin 5): External resistor divider from V_{REF} sets maximum duty cycle clamp ($SS_MAXDC = 1.84V$, $SD_V_{SEC} = 1.32V$ gives 72% duty cycle). Capacitor on SS_MAXDC pin in combination with external resistor divider sets soft-start timing.

V_{REF} (Pin 6): The output of an internal 2.5V reference which supplies control circuitry in the IC. Capable of sourcing up to 2.5mA drive for external use. Bypass to ground with a 0.1 μ F ceramic capacitor.

SD_V_{SEC} (Pin 7): The SD_V_{SEC} pin, when pulled below its accurate 1.32V threshold, is used to turn off the IC and reduce current drain from V_{IN} . The SD_V_{SEC} pin is connected to system input voltage through a resistor divider to define undervoltage lockout (UVLO) and to provide a

Volt-Second clamp on the OUT pin. A 10 μ A pin current hysteresis allows external programming of UVLO hysteresis.

GND (Pin 8): Analog Ground.

BLANK (Pin 9): A resistor to ground adjusts the extended blanking period of the over-current and current sense amplifier outputs during FET turn on — to prevent false current limit trip. Increasing the resistor value increases the blanking period.

I_{SENSE} (Pin 10): The Current Sense Input for the Control Loop. Connect this pin to the sense resistor in the source of the external power MOSFET. A resistor in series with the I_{SENSE} pin programs slope compensation.

OC (Pin 11): An accurate 100mV threshold, independent of duty cycle, for over-current detection and trigger of soft-start. Connect this pin directly to the sense resistor in the source of the external power MOSFET.

DELAY (Pin 12): A resistor to ground adjusts the delay period between SOUT rising edge and OUT rising edge. Used to maximize efficiency in forward converter applications by adjusting the control timing of secondary side synchronous rectifier MOSFETs. Increasing the resistor value increases the delay period.

PGND (Pin 13): Power Ground.

OUT (Pin 14): Drives the Gate of an N-channel MOSFET between 0V and V_{IN} . OUT is actively clamped to 13V. Active pull-off exists in shutdown (see electrical specification).

VIN (Pin 15): Input Supply for the Part. It must be closely decoupled to ground. An internal undervoltage lockout threshold exists for V_{IN} at approximately 14.25V on and 8.75V off.

SOUT (Pin 16): Switched Output in Phase with OUT Pin. Provides sync signal for control of secondary side FETs in forward converter applications requiring highly efficient synchronous rectification. SOUT is actively clamped to 12V. Active pull-off exists in shutdown (see electrical specification).

TIMING DIAGRAM

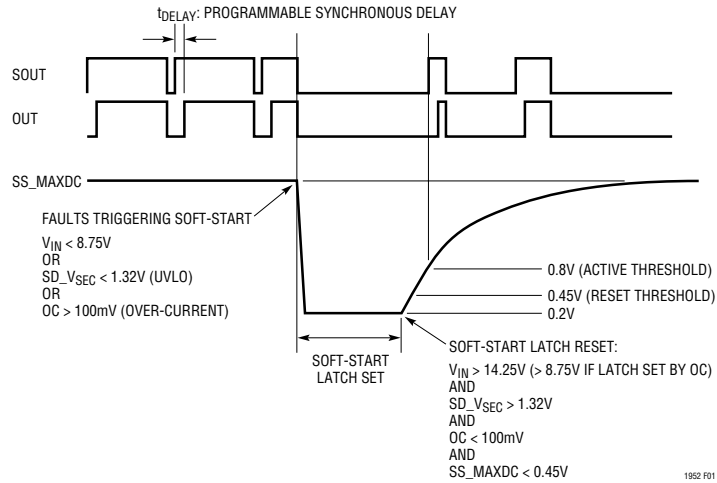

Figure 1. Timing Diagram

BLOCK DIAGRAM

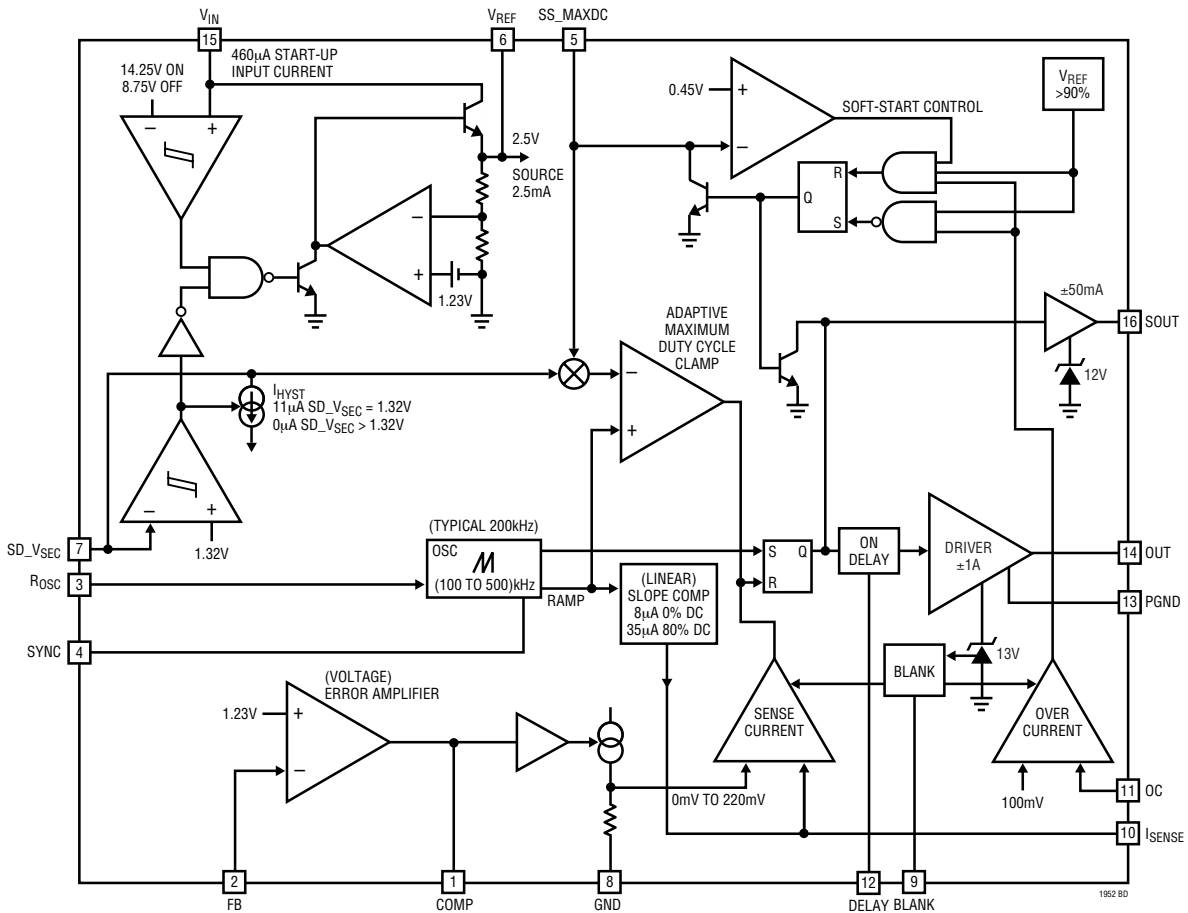

Figure 2. Block Diagram

OPERATION

Introduction

The LT1952 is a current mode synchronous PWM controller optimized for control of the simplest forward converter topology — using only one primary MOSFET. The LT1952 is ideal for 25W to 500W power systems where very high efficiency and reliability, low complexity and cost are required in a small space. Key features of the LT1952 include an adaptive maximum duty cycle clamp for the single primary MOSFET. An additional output signal is included for synchronous rectifier control. A precision 100mV threshold senses over-current conditions and triggers Soft-Start for low stress short circuit protection and control. The key functions of the LT1952 are shown in the Block Diagram in Figure 2.

Part Startup

In normal operation the SD_V_{SEC} pin must exceed 1.32V and the V_{IN} pin must exceed 14.25V to allow the part to turn on. This combination of pin voltages allows the 2.5V V_{REF} pin to become active, supplying the LT1952 control circuitry and providing up to 2.5mA external drive. SD_V_{SEC} threshold can be used for externally programming an undervoltage lockout (UVLO) threshold on the system input voltage. Hysteresis on the UVLO threshold can also be programmed since the SD_V_{SEC} pin draws 11 μ A just before part turn on and 0 μ A after part turn on.

With the LT1952 turned on, the V_{IN} pin can drop as low as 8.75V before part shutdown occurs. This V_{IN} pin hysteresis (5.5V) combined with low 460 μ A start-up input current allows low power start-up using a resistor/capacitor network from system V_{IN} to supply the V_{IN} pin (Figure 3). The V_{IN} capacitor value is chosen to prevent V_{IN} falling below 8.75V before an auxiliary winding in the converter takes over supply to the V_{IN} pin.

Output Drivers

The LT1952 has two outputs, SOUT and OUT. The OUT pin provides a ± 1 A peak MOSFET gate drive clamped to 13V. The SOUT pin has a ± 50 mA peak drive clamped to 12V and provides sync signal timing for synchronous rectification control.

For SOUT and OUT turn on, a PWM latch is set at the start of each main oscillator cycle. OUT turn on is delayed from SOUT turn on by a time t_{DELAY} (Figure 2). t_{DELAY} is programmed using a resistor from the DELAY pin to ground and is used to set the timing control of the secondary synchronous rectifiers for optimum efficiency.

SOUT and OUT turn off at the same time each cycle by one of three methods:

- (1) MOSFET peak current sense at I_{SENSE} pin
- (2) Adaptive maximum duty cycle clamp reached during load/line transients
- (3) Maximum duty cycle reset of the PWM latch

During any of the following conditions — low V_{IN} , low SD_V_{SEC} or over-current detection at the OC pin — a soft-start event is latched and both SOUT and OUT turn off immediately (Figure 1).

Leading Edge Blanking

To prevent MOSFET switching noise causing premature turn off of SOUT or OUT, programmable leading edge blanking exists. This means both the current sense comparator and over-current comparator outputs are ignored during MOSFET turn on and for an extended period after the OUT leading edge (Figure 6). The extended blanking period is programmable by adjusting a resistor from the BLANK pin to ground.

Adaptive Maximum Duty Cycle Clamp (Volt-Second Clamp)

For forward converter applications using the simplest topology of a single MOSFET on the primary, a maximum switch duty cycle clamp which adapts to transformer input voltage is necessary for reliable control of the MOSFET. This volt-second clamp provides a safeguard for transformer reset that prevents transformer saturation. Instantaneous load changes can cause the converter loop to demand maximum duty cycle. If the maximum duty cycle of the switch is too great, the transformer reset voltage can exceed the voltage rating of the primary-side MOSFET with catastrophic damage. Many converters solve this problem

OPERATION

by limiting the operational duty cycle of the MOSFET to 50% or less — or by using a fixed (non-adaptive) maximum duty cycle clamp with very large voltage rated MOSFETs. The LT1952 provides a volt-second clamp to allow MOSFET duty cycles well above 50%. This gives greater power utilization for the MOSFET, rectifiers and transformer resulting in less space for a given power output. In addition, the volt-second clamp allows a reduced voltage rating on the MOSFET resulting in lower $R_{DS(ON)}$ for greater efficiency. The volt-second clamp defines a maximum duty cycle 'guard rail' which falls when system input voltage increases.

The LT1952 SD_{VSEC} and SS_{MAXDC} pins provide a capacitorless, programmable volt-second clamp solution. Some controllers with volt-second clamps control switch maximum duty cycle by using an external capacitor to program maximum switch ON time. Such techniques have a volt-second clamp inaccuracy directly related to the error of the external capacitor/pin capacitance and the error/drift of the internal oscillator. The LT1952 uses simple resistor ratios to implement a volt-second clamp without the need for an accurate external capacitor and with an order of magnitude less dependency on oscillator error.

An increase of voltage at the SD_{VSEC} pin causes the maximum duty cycle clamp to decrease. If SD_{VSEC} is resistively divided down from transformer input voltage, a volt-second clamp is realised. To adjust the initial maximum duty cycle clamp, the SS_{MAXDC} pin voltage is programmed by a resistor divider from the 2.5V V_{REF} pin to ground. An increase of programmed voltage on SS_{MAXDC} pin provides an increase of switch maximum duty cycle clamp.

Soft-Start

The LT1952 provides true PWM soft-start by using the SS_{MAXDC} pin to control soft-start timing. The proportional relationship between SS_{MAXDC} voltage and switch maximum duty cycle clamp allows the SS_{MAXDC} pin to slowly ramp output voltage by ramping the maximum switch duty cycle clamp — until switch duty cycle clamp seamlessly meets the natural duty cycle of the converter.

A soft-start event is triggered whenever V_{IN} is too low, SD_{VSEC} is too low (UVLO), or a 100mV over-current threshold at OC pin is exceeded. Whenever a soft-start event is triggered, switching at SOUT and OUT is stopped immediately.

The SS_{MAXDC} pin is discharged and only released for charging when it has fallen below its reset threshold of 0.45V and all faults have been removed. Increasing voltage on the SS_{MAXDC} pin above 0.8V will increase switch maximum duty cycle. A capacitor to ground on the SS_{MAXDC} pin in combination with a resistor divider from V_{REF} , defines the soft-start timing.

Current Mode Topology (I_{SENSE} Pin)

The LT1952 current mode topology eases frequency compensation requirements because the output inductor does not contribute to phase delay in the regulator loop. This current mode technique means that the error amplifier (nonisolated applications) or the optocoupler (isolated applications) commands current (rather than voltage) to be delivered to the output. This makes frequency compensation easier and provides faster loop response to output load transients.

A resistor divider from the application's output voltage generates a voltage at the inverting FB input of the LT1952 error amplifier (or to the input of an external optocoupler) and is compared to an accurate reference (1.23V for LT1952). The error amplifier output (COMP) defines the input threshold (I_{SENSE}) of the current sense comparator. COMP voltages between 0.8V (active threshold) and 2.5V define a maximum I_{SENSE} threshold from 0mV to 220mV. By connecting I_{SENSE} to a sense resistor in series with the source of an external power MOSFET, the MOSFET peak current trip point (turn off) can be controlled by COMP level and hence by the output voltage. An increase in output load current causing the output voltage to fall, will cause COMP to rise, increasing I_{SENSE} threshold, increasing the current delivered to the output. For isolated applications, the error amplifier COMP output can be disabled to allow the optocoupler to take control. Setting $FB = V_{REF}$ disables the error amplifier COMP output, reducing pin current to $(COMP - 0.7)/40k$.

OPERATION

Slope Compensation

The current mode architecture requires slope compensation to be added to the current sensing loop to prevent subharmonic oscillations which can occur for duty cycles above 50%. Unlike most current mode converters which have a slope compensation ramp that is fixed internally, placing a constraint on inductor value and operating frequency, the LT1952 has externally adjustable slope compensation. Slope compensation can be programmed by inserting an external resistor (R_{SLOPE}) in series with the I_{SENSE} pin. The LT1952 has a linear slope compensation ramp which sources current out of the I_{SENSE} pin of approximately $8\mu A$ at 0% duty cycle to $35\mu A$ at 80% duty cycle.

Over-Current Detection and Soft-Start (OC Pin)

An added feature to the LT1952 is a precise 100mV sense threshold at the OC pin used to detect over-current conditions in the converter and set a soft-start latch. The OC pin

is connected directly to the source of the primary side MOSFET to monitor peak current in the MOSFET (Figure 7). The 100mV threshold is constant over the entire duty cycle range of the converter because it is unaffected by the slope compensation added to the I_{SENSE} pin.

Synchronizing

A SYNC pin allows the LT1952 oscillator to be synchronized to an external clock. The SYNC pin can be driven from a logic level output, requiring less than 0.8V for a logic level low and greater than 2.2V for a logic level high. Duty cycle should run between 10% and 90%. To avoid loss of slope compensation during synchronization, the free running oscillator frequency (f_{OSC}) should be programmed to 80% of the external clock frequency (f_{SYNC}). The R_{SLOPE} resistor chosen for non-synchronized operation should be increased by $1.25x (= f_{SYNC}/f_{OSC})$.

APPLICATIONS INFORMATION

Shutdown and Programming Undervoltage Lockout

The LT1952 has an accurate 1.32V shutdown threshold at the SD_V_{SEC} pin. This threshold can be used in conjunction with a resistor divider to define the undervoltage lockout threshold (UVLO) of the system input voltage (V_S) to the power converter (Figure 3). A pin current hysteresis ($11\mu A$ before part turn on, $0\mu A$ after part turn on) allows UVLO hysteresis to be programmed. Calculation of the ON/OFF thresholds for the supply (SV_{IN}) to the power converter can be made as follows:

$$V_{S\ OFF\ Threshold} = 1.32[1 + (R1/R2)]$$

$$V_{S\ ON\ Threshold} = SV_{IN\ OFF} + (11\mu A \cdot R1)$$

A simple open drain transistor can be added to the resistor divider network at the SD_V_{SEC} pin to control the turn off of the LT1952 (Figure 3).

The SD_V_{SEC} pin must not be left open since there must be an external source current $>11\mu A$ to lift the pin past its 1.32V threshold for part turn on.

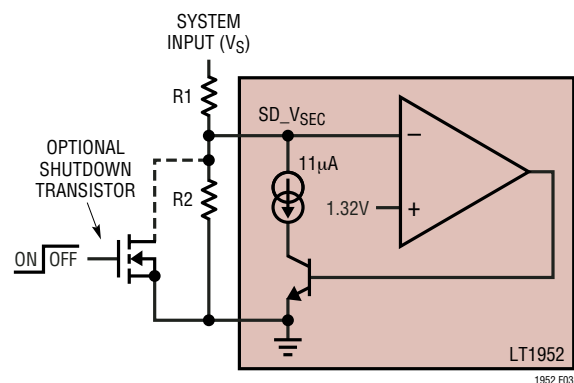

Figure 3. Programming Undervoltage Lockout (UVLO)

Micropower Start-Up: Selection of Start-Up Resistor and Capacitor for V_{IN}

The LT1952 uses turn-on voltage hysteresis at the V_{IN} pin and low start-up current to allow micro-power start-up (Figure 4). The LT1952 monitors V_{IN} pin voltage to allow part turn on at 14.25V and part turn off at 8.75V. Low start-up current ($460\mu A$) allows a large resistor to be connected

APPLICATIONS INFORMATION

between system input supply and V_{IN} . Once the part is turned on, input current increases to drive the IC (I_{START}) and the output drivers (I_{DRIVE}). A large enough capacitor is chosen at the V_{IN} pin to prevent V_{IN} falling below 8.5V before an auxiliary winding in the converter takes over supply to V_{IN} . This technique allows a simple resistor/capacitor for start-up which draws low power from the system supply to the converter. The values for R_{START} and C_{START} are given by:

$$R_{START(MAX)} = (V_{S(MIN)} - V_{IN ON(MAX)}) / I_{START(MAX)}$$

$$C_{START(MIN)} = (I_Q(MAX) + I_{DRIVE(MAX)}) \cdot t_{START} / V_{IN HYST(MIN)}$$

Example:

For $V_{S(MIN)} = 36V$, $V_{IN ON(MAX)} = 15.75V$,
 $I_{START(MAX)} = 700\mu A$, $I_Q(MAX) = 5.5mA$,
 $I_{DRIVE(MAX)} = 5mA$, $V_{IN HYST(MIN)} = 3.75V$
 and $t_{START} = 100\mu s$,

$$R_{START} = (36 - 15.75) / 700\mu A = 28.9k \text{ (choose } 28.7k)$$

$$C_{START} = (5.5mA + 5mA) \cdot 100\mu s / 3.75V = 0.28\mu F$$

(typically choose $\geq 1\mu F$)

For system input voltages exceeding the absolute maximum rating of the LT1952 V_{IN} pin, an external zener should be connected from the V_{IN} pin to ground. This covers the condition where V_{IN} charges past $V_{IN ON}$ (typically 14.25V) but the part does not turn on because $SD_V_{SEC} < 1.32V$. In this condition V_{IN} will continue to charge towards system

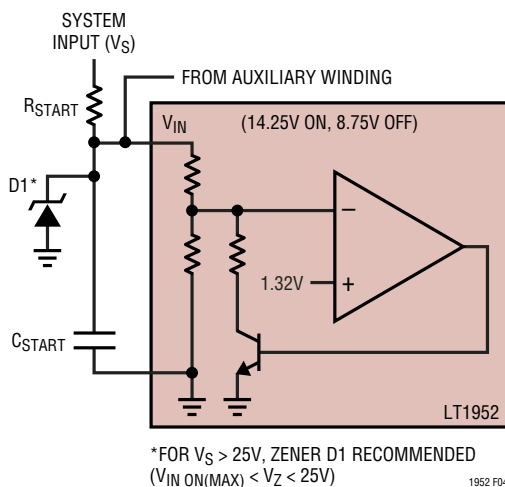

Figure 4. Low Power Start-Up

V_{IN} , possibly exceeding the rating for the V_{IN} pin. The zener voltage should obey $V_{IN ON(MAX)} < V_Z < 25V$.

Programming Oscillator Frequency

The oscillator frequency (f_{OSC}) of the LT1952 is programmed using an external resistor (R_{OSC}) connected between the R_{OSC} pin and ground. Figure 5 shows typical f_{OSC} vs. R_{OSC} resistor values. The LT1952 free-running oscillator frequency is programmable in the range of 100kHz to 500kHz.

Stray capacitance and potential noise pickup on the R_{OSC} pin should be minimized by placing the R_{OSC} resistor as close as possible to the R_{OSC} pin and keeping the area of the R_{OSC} node as small as possible. The ground side of the R_{OSC} resistor should be returned directly to the (analog ground) GND pin. R_{OSC} can be calculated by,

$$R_{OSC} = 9.125k [(4100k/f_{OSC}) - 1]$$

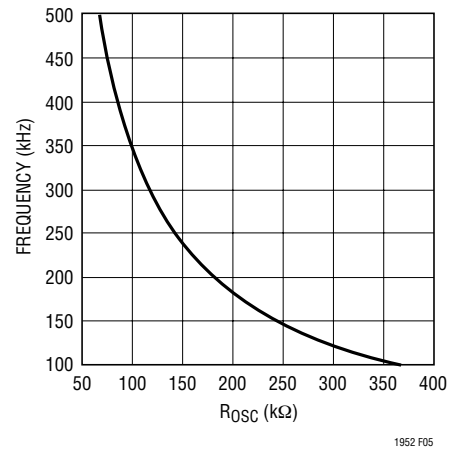

Figure 5. Oscillator Frequency (f_{osc}) vs R_{osc}

Programming Leading Edge Blank Time

For PWM controllers driving external MOSFETs, noise can be generated at the source of the MOSFET during gate rise time and some time thereafter. This noise can potentially exceed the OC and I_{SENSE} pin thresholds of the LT1952 to cause premature turn off of SOUT and OUT in addition to false trigger of soft-start. The LT1952 provides programmable leading edge blanking of the OC and I_{SENSE} comparator outputs to avoid false current sensing during MOSFET switching.

APPLICATIONS INFORMATION

Blanking is provided in 2 phases (Figure 6): The first phase automatically blanks during gate rise time. Gate rise times can vary depending on MOSFET type. For this reason the LT1952 performs true 'leading edge blanking' by automatically blanking OC and I_{SENSE} comparator outputs until OUT rises to within 0.5V of V_{IN} or reaches its clamp level of 13V. The second phase of blanking starts after the leading edge of OUT has been completed. This phase is programmable by the user with a resistor connected from the BLANK pin to ground. Typical durations for this portion of the blanking period are from 45ns at R_{BLANK} = 10k to 540ns at R_{BLANK} = 120k. Blanking duration can be approximated as:

$$\text{Blanking (extended)} = [45(R_{\text{BLANK}}/10\text{k})]\text{ns}$$

(see graph in Typical Performance Characteristics)

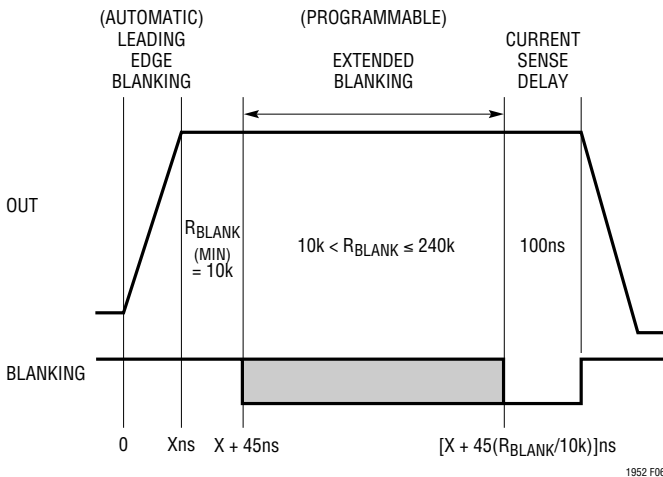

Figure 6. Leading Edge Blank Timing

Programming Current Limit (OC Pin)

The LT1952 uses a precise 100mV sense threshold at the OC pin to detect over-current conditions in the converter and set a soft-start latch. It is independent of duty cycle because it is not affected by slope compensation programmed at the I_{SENSE} pin. The OC pin monitors the peak current in the primary MOSFET by sensing the voltage across a sense resistor (R_S) in the source of the MOSFET.

The current limit for the converter can be programmed by,

$$\text{Current limit} = (100\text{mV}/R_{\text{S}})(N_{\text{P}}/N_{\text{S}}) - (1/2)(I_{\text{RIPPLE}})$$

where,

R_S = sense resistor in source of primary MOSFET

I_{RIPPLE} = p-p ripple current in the output inductor L1

N_S = number of transformer secondary turns

N_P = number of transformer primary turns

Programming Slope Compensation

The LT1952 uses a current mode architecture to provide fast response to load transients and to ease frequency compensation requirements. Current mode switching regulators which operate with duty cycles above 50% and have continuous inductor current must add slope compensation to their current sensing loop to prevent subharmonic oscillations. (For more information on slope compensation, see Application Note 19.) The LT1952 has programmable slope compensation to allow a wide range of inductor values, to reduce susceptibility to PCB generated noise and to optimize loop bandwidth. The LT1952 programs slope compensation by inserting a resistor R_{SLOPE} in series with the I_{SENSE} pin (Figure 7). The LT1952 generates a current at the I_{SENSE} pin which is linear from 0% duty cycle to the maximum duty cycle of the OUT pin. A simple calculation of I(I_{SENSE}) • R_{SLOPE} gives an added ramp to the voltage at the I_{SENSE} pin for programmable slope compensation. (See both graphs 'I_{SENSE} Pin Current vs. Duty Cycle' and 'I_{SENSE} Maximum Threshold vs Duty Cycle' in the Typical Performance Characteristics section.)

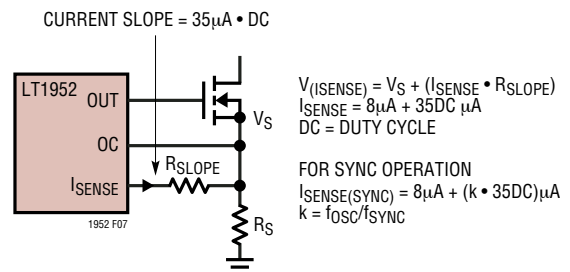

Figure 7. Programming Slope Compensation

APPLICATIONS INFORMATION

Programming Synchronous Rectifier Timing: SOUT to OUT delay ('t_{DELAY}')

The LT1952 has an additional output SOUT which provides a ±50mA peak drive clamped to 12V. In applications requiring synchronous rectification for high efficiency, the LT1952 SOUT provides a sync signal for secondary side control of the synchronous rectifier MOSFETs (Figure 11). Timing delays through the converter can cause non-optimum control timing for the synchronous rectifier MOSFETs. The LT1952 provides a programmable delay (t_{DELAY}, Figure 8) between SOUT rising edge and OUT rising edge to optimize timing control for the synchronous rectifier MOSFETs to achieve maximum efficiency gains. A resistor R_{DELAY} connected from the DELAY pin to ground sets the value of t_{DELAY}. Typical values for t_{DELAY} range from 10ns with R_{DELAY} = 10k to 160ns with R_{DELAY} = 160k. (see graph in Typical Performance Characteristics)

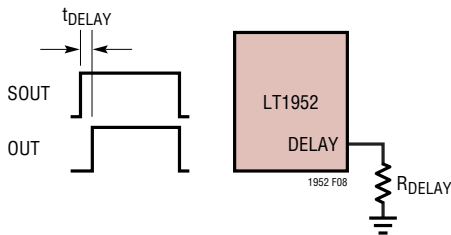

Figure 8. Programming SOUT to OUT Delay: t_{DELAY}

Programming Maximum Duty Cycle Clamp

For forward converter applications using the simplest topology of a single MOSFET on the primary, a maximum switch duty cycle clamp which adapts to transformer input voltage is necessary for reliable control of the MOSFET. This volt-second clamp provides a safeguard for transformer reset that prevents transformer saturation. The LT1952 SD_{VSEC} and SS_{MAXDC} pins provide a capacitor-less, programmable volt-second clamp solution using simple resistor ratios (Figure 9).

An increase of voltage at the SD_{VSEC} pin causes the maximum duty cycle clamp to decrease. Deriving SD_{VSEC} from a resistor divider connected to system input voltage creates the volt-second clamp. The maximum duty cycle clamp can be adjusted by programming voltage on the

SS_{MAXDC} pin using a resistor divider from V_{REF}. An increase of voltage at the SS_{MAXDC} pin causes the maximum duty cycle clamp to increase.

To program the volt-second clamp, the following steps should be taken:

- (1) The maximum operational duty cycle of the converter should be calculated for the given application.
- (2) An initial value for the maximum duty cycle clamp should be calculated using the equation below with a first pass guess for SS_{MAXDC}.

Note: Since maximum operational duty cycle occurs at minimum system input voltage (UVLO), the voltage at the SD_{VSEC} pin = 1.32V.

$$\begin{aligned} \text{Max Duty Cycle Clamp (OUT pin)} \\ = k \cdot 0.522(\text{SS_MAXDC(DC)}/\text{SD_VSEC}) - \\ (t_{\text{DELAY}} \cdot f_{\text{OSC}}) \end{aligned}$$

where,

$$\text{SS_MAXDC(DC)} = V_{\text{REF}}(R_B/(R_T + R_B))$$

$$\text{SD_VSEC} = 1.32\text{V at minimum system input voltage}$$

$$t_{\text{DELAY}} = \text{programmed delay between SOUT and OUT}$$

$$k = 1.11 - 5.5e^{-7} \cdot (f_{\text{OSC}})$$

- (3) The maximum duty cycle clamp calculated in (2) should be programmed to be 10% greater than the maximum operational duty cycle calculated in (1). Simple adjustment of maximum duty cycle can be achieved by adjusting SS_{MAXDC}.

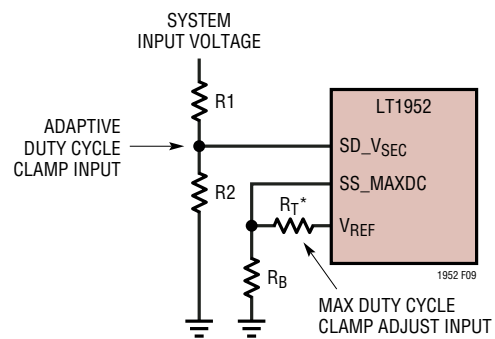

*MINIMUM ALLOWABLE R_T IS 10k TO GUARANTEE SOFT-START PULL-OFF

Figure 9. Programming Maximum Duty Cycle Clamp

APPLICATIONS INFORMATION

Example calculation for (2)

For $R_T = 35.7k$, $R_B = 100k$, $V_{REF} = 2.5V$,
 $R_{DELAY} = 40k$, $f_{OSC} = 200kHz$ and $SD_V_{SEC} = 1.32V$,
 this gives $SS_MAXDC(DC) = 1.84V$, $t_{DELAY} = 40ns$
 and $k = 1$

Maximum Duty Cycle Clamp
 $= 1 \cdot 0.522(1.84/1.32) - (40ns \cdot 200kHz)$
 $= 0.728 - 0.008 = 0.72$ (Duty Cycle Clamp = 72%)

Note 1: To achieve the same maximum duty cycle clamp at 100kHz as calculated for 200kHz, the SS_MAXDC voltage should be reprogrammed by,

$SS_MAXDC(DC)$ (100kHz)
 $= SS_MAXDC(DC)$ (200kHz) $\cdot k$ (200kHz)/ k (100kHz)
 $= 1.84 \cdot 1.0/1.055 = 1.74V$ ($k = 1.055$ for 100kHz)

The second order effect of t_{DELAY} should also be considered for final adjustment of $SS_MAXDC(DC)$.

Note 2 : To achieve the same maximum duty cycle clamp while synchronizing to an external clock at the $SYNC$ pin, the SS_MAXDC voltage should be re-programmed as,

SS_MAXDC (DC) (f_{sync})
 $= SS_MAXDC$ (DC) (200kHz) $\cdot [(f_{osc}/f_{sync}) + 0.09(f_{osc}/200kHz)^{0.6}]$

For SS_MAXDC (DC) (200kHz) = 1.84V for 72% duty cycle

SS_MAXDC (DC) ($f_{sync} = 250kHz$) for 72% duty cycle
 $= 1.84 \cdot [(200kHz/250kHz) + 0.09(1)^{0.6}]$
 $= 1.638V$

Programming Soft-Start Timing

The LT1952 has built-in soft-start capability to provide low stress controlled startup from a list of fault conditions that can occur in the application (see Figure 1 and Figure 10). The LT1952 provides true PWM soft-start by using the SS_MAXDC pin to control soft-start timing. The proportional relationship between SS_MAXDC voltage and switch maximum duty cycle clamp allows the SS_MAXDC pin to slowly ramp output voltage by ramping the maximum switch duty cycle clamp — until switch duty cycle clamp seamlessly meets the natural duty cycle of the converter.

A capacitor C_{SS} on the SS_MAXDC pin and the resistor divider from V_{REF} used to program maximum switch duty cycle clamp, determine soft-start timing (Figure 11).

A soft-start event is triggered for the following faults:

- (1) $V_{IN} < 8.75V$, or
- (2) $SD_V_{SEC} < 1.32V$ (UVLO), or
- (3) $OC > 100mV$ (over-current condition)

When a soft-start event is triggered, switching at $SOUT$ and OUT is stopped immediately. A soft-start latch is set and SS_MAXDC pin is discharged. The SS_MAXDC pin can only recharge when the soft-start latch has been reset.

Note: A soft-start event caused by (1) or (2) above, also causes V_{REF} to be disabled and to fall to ground.

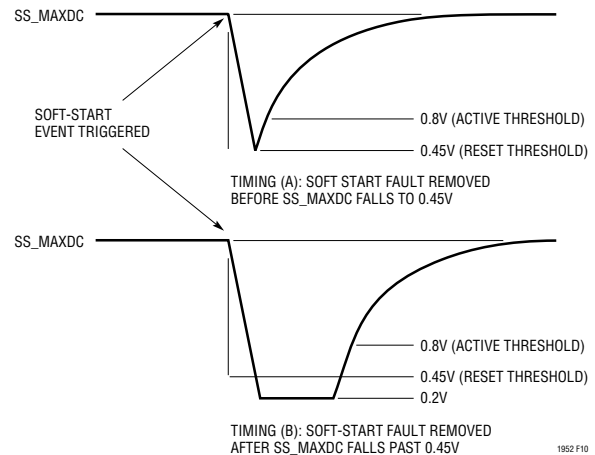
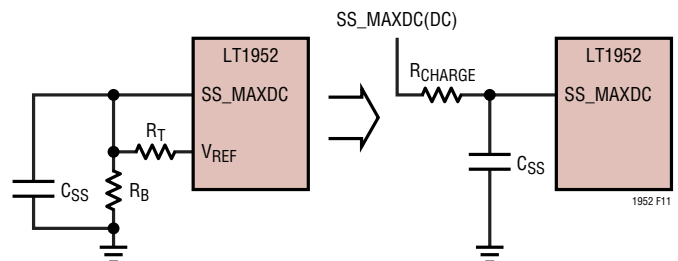

Figure 10. Soft-Start Timing



SS_MAXDC CHARGING MODEL
 $SS_MAXDC(DC) = V_{REF} [R_B/(R_T + R_B)]$
 $R_{CHARGE} = [R_T \cdot R_B/(R_T + R_B)]$

Figure 11. Programming Soft-Start Timing

APPLICATIONS INFORMATION

Soft-start latch reset requires all of the following:

- (A) $V_{IN} > 14.25^*$, and
- (B) $SD_V_{SEC} > 1.32V$, and
- (C) $OC < 100mV$, and
- (D) $SS_MAXDC < 0.45V$ (SS_MAXDC reset threshold)

* $V_{IN} > 8.75V$ is ok for latch reset if the latch was only set by over-current condition in (3) above

SS_MAXDC Discharge Timing

It can be seen in Figure 10 that two types of discharge can occur for the SS_MAXDC pin. In timing (A) the fault that caused the soft-start event has been removed before SS_MAXDC falls to 0.45V. This means the soft-start latch will be reset when SS_MAXDC falls to 0.45V and SS_MAXDC will begin charging. In timing (B), the fault that caused the soft-start event is not removed until some time after SS_MAXDC has fallen past 0.45V. The SS_MAXDC pin continues to discharge to 0.2V and remains low until all faults are removed.

The time for SS_MAXDC to fall to a given voltage can be approximated as,

$$SS_MAXDC(t_{FALL}) = (C_{SS}/I_{DIS}) \cdot [SS_MAXDC(DC) - V_{SS(MIN)}]$$

where,

- I_{DIS} = net discharge current on C_{SS}
- C_{SS} = capacitor value at SS_MAXDC pin
- $SS_MAXDC(DC)$ = programmed DC voltage
- $V_{SS(MIN)}$ = minimum SS_MAXDC voltage before recharge
- $I_{DIS} \sim 8e^{-4} + (V_{REF} - V_{SS(MIN)})[(1/2R_B) - (1/R_T)]$

For faults arising from (1) and (2),

$$V_{REF} = 100mV.$$

For a fault arising from (3),

$$V_{REF} = 2.5V.$$

$$SS_MAXDC(DC) = V_{REF}[R_B/(R_T + R_B)]$$

$$V_{SS(MIN)} = SS_MAXDC \text{ reset threshold} = 0.45V \text{ (if fault removed before } t_{FALL})$$

Example

For an over-current fault ($OC > 100mV$), $V_{REF} = 2.5V$, $R_T = 35.7k$, $R_B = 100k$, $C_{SS} = 0.1\mu F$ and assume $V_{SS(MIN)} = 0.45V$,
 $I_{DIS} \sim 8e^{-4} + (2.5 - 0.45)[(1/2 \cdot 100k) - (1/35.7k)]$
 $= 8e^{-4} + (2.05)(-0.23e^{-4}) = 7.5e^{-4}$

$$SS_MAXDC(DC) = 1.84V$$

$$SS_MAXDC(t_{FALL}) = (1e - 7/7.5e^{-4}) \cdot (1.84 - 0.45) = 1.85e^{-4} \text{ s}$$

If the OC fault is not removed before $185\mu s$ then SS_MAXDC will continue to fall past 0.45V towards a new $V_{SS(MIN)}$. The typical V_{OL} for SS_MAXDC at $150\mu A$ is 0.2V.

SS_MAXDC Charge Timing

When all faults are removed and the SS_MAXDC pin has fallen to its reset threshold of 0.45V or lower, the SS_MAXDC pin will be released and allowed to charge.

SS_MAXDC will rise until it settles at its programmed DC voltage — setting the maximum switch duty cycle clamp. The calculation of charging time for the SS_MAXDC pin between any two voltage levels can be approximated as an RC charging waveform using the model shown in Figure 11.

The ability to predict SS_MAXDC rise time between any two voltages allows prediction of several key timing periods:

- (1) No Switching Period
(time from $SS_MAXDC(DC)$ to $V_{SS(MIN)}$ + time from $V_{SS(MIN)}$ to $V_{SS(ACTIVE)}$)
- (2) Converter Output Rise Time
(time from $V_{SS(ACTIVE)}$ to $V_{SS(REG)}$; $V_{SS(REG)}$ is the level of SS_MAXDC where maximum duty cycle clamp equals the natural duty cycle of the switch)
- (3) Time For Maximum Duty Cycle Clamp within X% of Target Value

The time for SS_MAXDC to charge to a given voltage V_{SS} is found by re-arranging,

$$V_{SS}(t) = SS_MAXDC(DC) (1 - e^{(-t/RC)})$$

APPLICATIONS INFORMATION

to give,

$$t = RC \cdot (-1) \cdot \ln(1 - V_{SS}/SS_MAXDC(DC))$$

where,

V_{SS} = SS_MAXDC voltage at time t

$SS_MAXDC(DC)$ = programmed DC voltage setting
maximum duty cycle clamp =

$$V_{REF}(R_B/(R_T + R_B))$$

$$R = R_{CHARGE} \text{ (Figure 11)} = R_T \cdot R_B/(R_T + R_B)$$

$$C = C_{SS} \text{ (Figure 11)}$$

Example (1) No Switching Period

The period of no switching for the converter, when a soft-start event has occurred, depends on how far SS_MAXDC can fall before recharging occurs and how long a fault exists. It will be assumed that a fault triggering soft-start is removed before SS_MAXDC can reach its reset threshold (0.45V).

$$\text{No Switching Period} = t_{DISCHARGE} + t_{CHARGE}$$

$t_{DISCHARGE}$ = discharge time from $SS_MAXDC(DC)$ to 0.45V

t_{CHARGE} = charge time from 0.45V to $V_{SS(ACTIVE)}$

$t_{DISCHARGE}$ was already calculated earlier as 185 μ s.

t_{CHARGE} is calculated by assuming the following:

$$V_{REF} = 2.5V, R_T = 35.7k, R_B = 100k, C_{SS} = 0.1\mu F \text{ and } V_{SS(MIN)} = 0.45V.$$

$$t_{CHARGE} = t(V_{SS} = 0.8V) - t(V_{SS} = 0.45V)$$

Step 1:

$$SS_MAXDC(DC) = 2.5[100k/(35.7k + 100k)] = 1.84V$$

$$R_{CHARGE} = (35.7k \cdot 100k/135.7k) = 26.3k$$

Step 2:

$t(V_{SS} = 0.45V)$ is calculated from,

$$\begin{aligned} t &= R_{CHARGE} \cdot C_{SS} \cdot (-1) \cdot \ln(1 - V_{SS}/SS_MAXDC(DC)) \\ &= 2.63e^4 \cdot 1e^{-7} \cdot (-1) \cdot \ln(1 - 0.45/1.84) \\ &= 2.63e^{-3} \cdot (-1) \cdot \ln(0.755) = 7.3e^{-4} \text{ s} \end{aligned}$$

Step 3:

$t(V_{SS} = 0.8V)$ is calculated from,

$$\begin{aligned} t &= R_{CHARGE} \cdot C_{SS} \cdot (-1) \cdot \ln(1 - V_{SS}/SS_MAXDC(DC)) \\ &= 2.63e^4 \cdot 1e^{-7} \cdot (-1) \cdot \ln(1 - 0.8/1.84) \\ &= 2.63e^{-3} \cdot (-1) \cdot \ln(0.565) = 1.5e^{-3} \text{ s} \end{aligned}$$

From Step 1 and Step 2

$$t_{CHARGE} = (1.5 - 0.73)e^{-3} \text{ s} = 7.7e^{-4} \text{ s}$$

The total time of no switching for the converter due to a soft-start event

$$= t_{DISCHARGE} + t_{CHARGE} = 1.85e^{-4} + 7.7e^{-4} = 9.55e^{-4} \text{ s}$$

Example (2) Converter Output Rise Time

The rise time for the converter output to reach regulation can be closely approximated as the time between the start of switching ($SS_MAXDC = V_{SS(ACTIVE)}$) and the time where converter duty cycle is in regulation ($DC(REG)$) and no longer controlled by SS_MAXDC ($SS_MAXDC = V_{SS(REG)}$). Converter output rise time can be expressed as,

$$\text{Output Rise Time} = t(V_{SS(REG)}) - t(V_{SS(ACTIVE)})$$

Step 1: Determine converter duty cycle $DC(REG)$ for output in regulation

The natural duty cycle $DC(REG)$ of the converter depends on several factors. For this example it is assumed that $DC(REG) = 60\%$ for system input voltage near the undervoltage lockout threshold (UVLO). This gives $SD_V_{SEC} = 1.32V$.

Also assume that the maximum duty cycle clamp programmed for this condition is 72% for $SS_MAXDC(DC) = 1.84V$, $f_{OSC} = 200kHz$ and $R_{DELAY} = 40k$.

Step 2: Calculate $V_{SS(REG)}$

To calculate the level of SS_MAXDC ($V_{SS(REG)}$) that no longer clamps the natural duty cycle of the converter, the equation for maximum duty cycle clamp must be used (see previous section 'Programming Maximum Duty Cycle Clamp').

The point where the maximum duty cycle clamp meets $DC(REG)$ during soft-start is given by,

$$DC(REG) = \text{Max Duty Cycle clamp}$$

APPLICATIONS INFORMATION

$$0.6 = k \cdot 0.522(SS_MAXDC(DC)/SD_VSEC) - (t_{DELAY} \cdot f_{OSC})$$

$$\text{For } SD_VSEC = 1.32V, f_{OSC} = 200kHz \text{ and } R_{DELAY} = 40k$$

This gives $k = 1$ and $t_{DELAY} = 40ns$.

Re-arranging the above equation to solve for $SS_MAXDC = V_{SS(REG)}$

$$\begin{aligned} &= [0.6 + (t_{DELAY} \cdot f_{OSC})(SD_VSEC)] / (k \cdot 0.522) \\ &= [0.6 + (40ns \cdot 200kHz)(1.32V)] / (1 \cdot 0.522) \\ &= (0.608)(1.32) / 0.522 = 1.537V \end{aligned}$$

Step 3: Calculate $t(V_{SS(REG)}) - t(V_{SS(ACTIVE)})$

Recall the time for SS_MAXDC to charge to a given voltage V_{SS} is given by,

$$t = R_{CHARGE} \cdot C_{SS} \cdot (-1) \cdot \ln(1 - V_{SS}/SS_MAXDC(DC))$$

(Figure 11 gives the model for SS_MAXDC charging)

$$\text{For } R_T = 35.7k, R_B = 100k, R_{CHARGE} = 26.3k$$

$$\begin{aligned} \text{For } C_{SS} = 0.1\mu F, \text{ this gives } t(V_{SS(ACTIVE)}) \\ &= t(V_{SS(0.8V)}) = 2.63e^4 \cdot 1e^{-7} \cdot (-1) \cdot \ln(1 - 0.8/1.84) \\ &= 2.63e^{-3} \cdot (-1) \cdot \ln(0.565) = 1.5e^{-3} \text{ s} \end{aligned}$$

$$\begin{aligned} t(V_{SS(REG)}) = t(V_{SS(1.537V)}) &= 26.3k \cdot 0.1\mu F \cdot -1 \cdot \\ \ln(1 - 1.66/1.84) &= 2.63e^{-3} \cdot (-1) \cdot \ln(0.146) \\ &= 5e^{-3} \text{ s} \end{aligned}$$

The rise time for the converter output

$$\begin{aligned} &= t(V_{SS(REG)}) - t(V_{SS(ACTIVE)}) = (5 - 1.5)e^{-3} \text{ s} \\ &= 3.5e^{-3} \text{ s} \end{aligned}$$

Example (3) Time For Maximum Duty Cycle Clamp to Reach Within X% of Target Value

A maximum duty cycle clamp of 72% was calculated previously in the section 'Programming Maximum Duty Cycle Clamp'. The programmed value used for $SS_MAXDC(DC)$ was 1.84V.

The time for SS_MAXDC to charge from its minimum value $V_{SS(MIN)}$ to within X% of $SS_MAXDC(DC)$ is given by,

$$\begin{aligned} &t(SS_MAXDC \text{ charge time within } X\% \text{ of target}) \\ &= t[(1 - (X/100) \cdot SS_MAXDC(DC))] - t(V_{SS(MIN)}) \end{aligned}$$

$$\text{For } X = 2 \text{ and } V_{SS(MIN)} = 0.45V, t(0.98 \cdot 1.84) - t(0.45) = t(1.803) - t(0.45)$$

From previous calculations, $t(0.45) = 7.3e^{-4} \text{ s}$.

Using previous values for R_T , R_B , and C_{SS} ,

$$\begin{aligned} t(1.803) &= 2.63e^{-4} \cdot 1e^{-7} \cdot (-1) \cdot \ln(1 - 1.803/1.84) \\ &= 2.63e^{-3} \cdot (-1) \cdot \ln(0.02) = 1.03e^{-2} \text{ s} \end{aligned}$$

Hence the time for SS_MAXDC to charge from its minimum reset threshold of 0.45V to within 2% of its target value is given by,

$$\begin{aligned} t(1.803) - t(0.45) &= \\ 1.03e^{-2} - 7.3e^{-4} &= 9.57e^{-3} \end{aligned}$$

Forward Converter Applications

The following section covers applications where the LT1952 is used in conjunction with other LTC parts to provide highly efficient power converters using the single switch forward converter topology.

95% Efficient, 5V, Synchronous Forward Converter

The circuit in Figure 14 is based on the LT1952 to provide the simplest forward power converter circuit — using only one primary MOSFET. The SOUT pin of the LT1952 provides a synchronous control signal for the LTC1698 located on the secondary. The LTC1698 drives secondary side synchronous rectifier MOSFETs to achieve high efficiency. The LTC1698 also serves as an error amplifier and optocoupler driver.

Efficiency and transient response are shown in Figures 12 and 13. Peak efficiencies of 95% and ultra-fast transient response are superior to presently available power modules. Integrated soft-start, over-current detection and short circuit hiccup mode provide low stress, reliable protection. In addition, the circuit in Figure 14 is an all-ceramic capacitor solution providing low output ripple voltage and improved reliability. The LT1952-based converter can be used to replace power module converters at a much lower cost. The LT1952 solution benefits from thermal conduction of the system board resulting in higher efficiencies and lower rise in component temperatures. The 7mm height allows dense packaging and the circuit can easily be adjusted to provide an output voltage from 1.23V to 26V. Higher currents are achievable by simple scaling of power components. The LT1952-based solution in Figure 14 is a powerful topology for replacement of a wide range of power modules.

APPLICATIONS INFORMATION

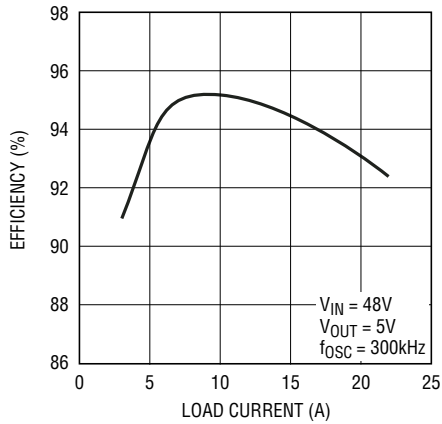

1952 F12

Figure 12. LT1952-Based Synchronous Forward Converter Efficiency vs Load Current (For Circuit in Figure 14)

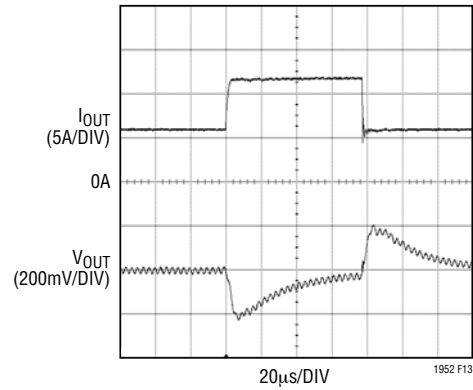
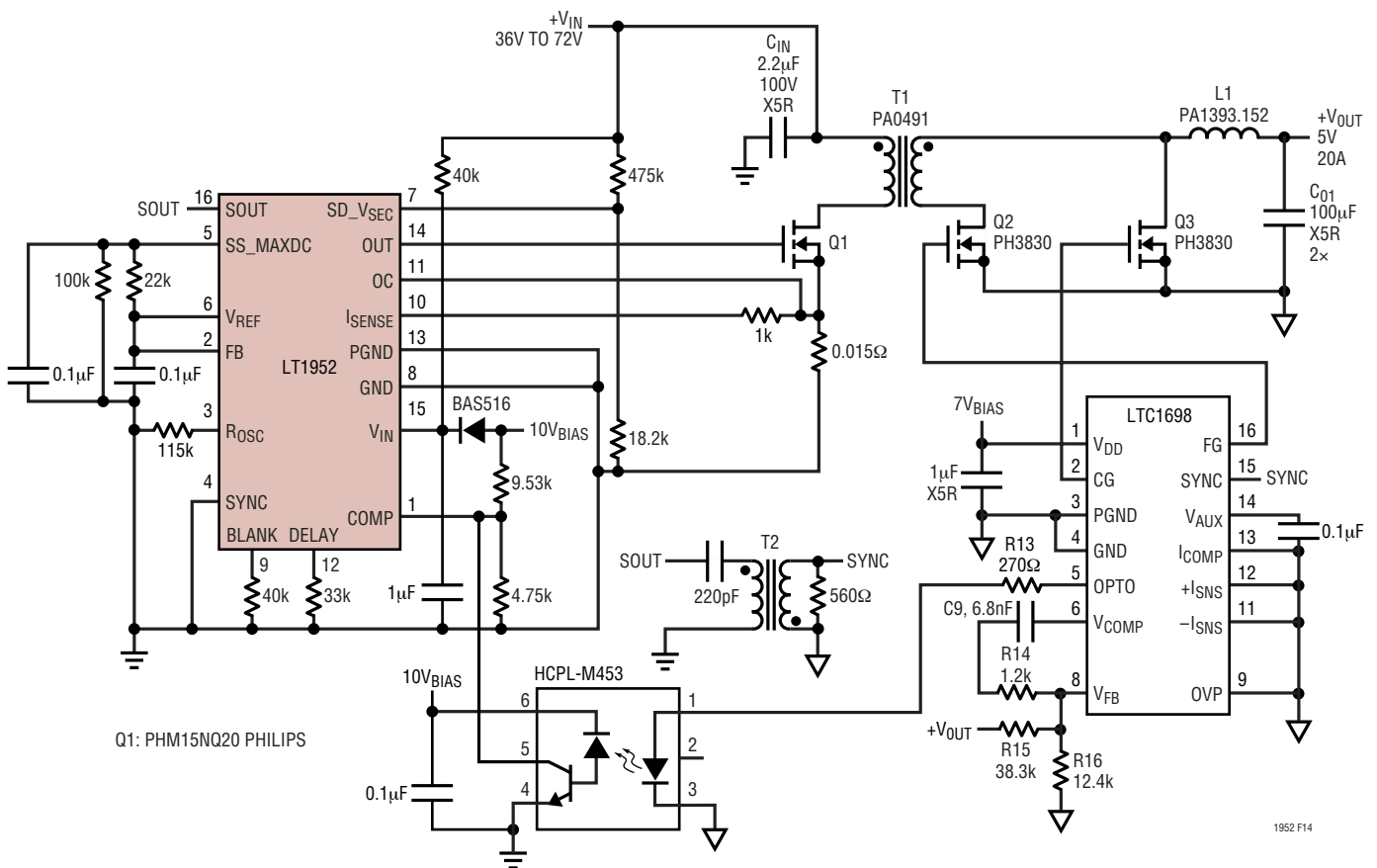

Figure 13. Output Voltage Transient Response (6A to 12A Load Step at 6A/µs)



1952 F14

Figure 14. 36V to 72V Input to 5V at 20A Synchronous Forward Converter

APPLICATIONS INFORMATION

36V to 72V Input, 3.3V 40A Converter

An LT1952-based synchronous forward converter provides the ideal solution for power supplies requiring high efficiency at low output voltages and high load currents. The 3.3V 40A solution in Figure 18 achieves peak efficiencies of 92.5% (Figure 17) by minimizing power loss due to rectification at the output. Synchronous rectifier control output SOUT, with programmable delay, optimizes timing control for a secondary side synchronous MOSFET controller (LTC3900) which results in high efficiency synchronous rectification. The LT1952 uses a precision current limit threshold at the OC pin combined with a soft-start hiccup mode to provide low stress output short circuit protection. The maximum output current will vary only 10% over the full V_{IN} range. During short circuit the average power dissipation of the circuit will be lower than 15% of maximum rated power thanks to a soft-start

controlled hiccup mode. This allows a significant reduction in power component sizing using the LT1952-based converter.

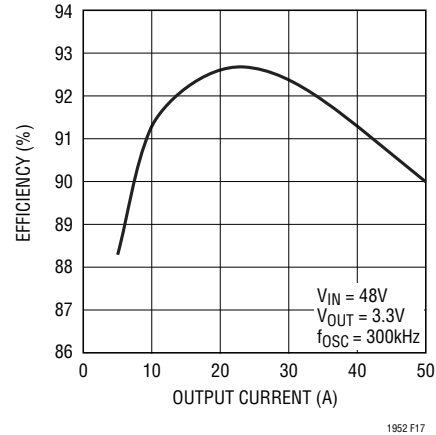

Figure 17. LT1952-Based Synchronous Forward Converter Efficiency vs Load Current (For Circuit in Figure 18)

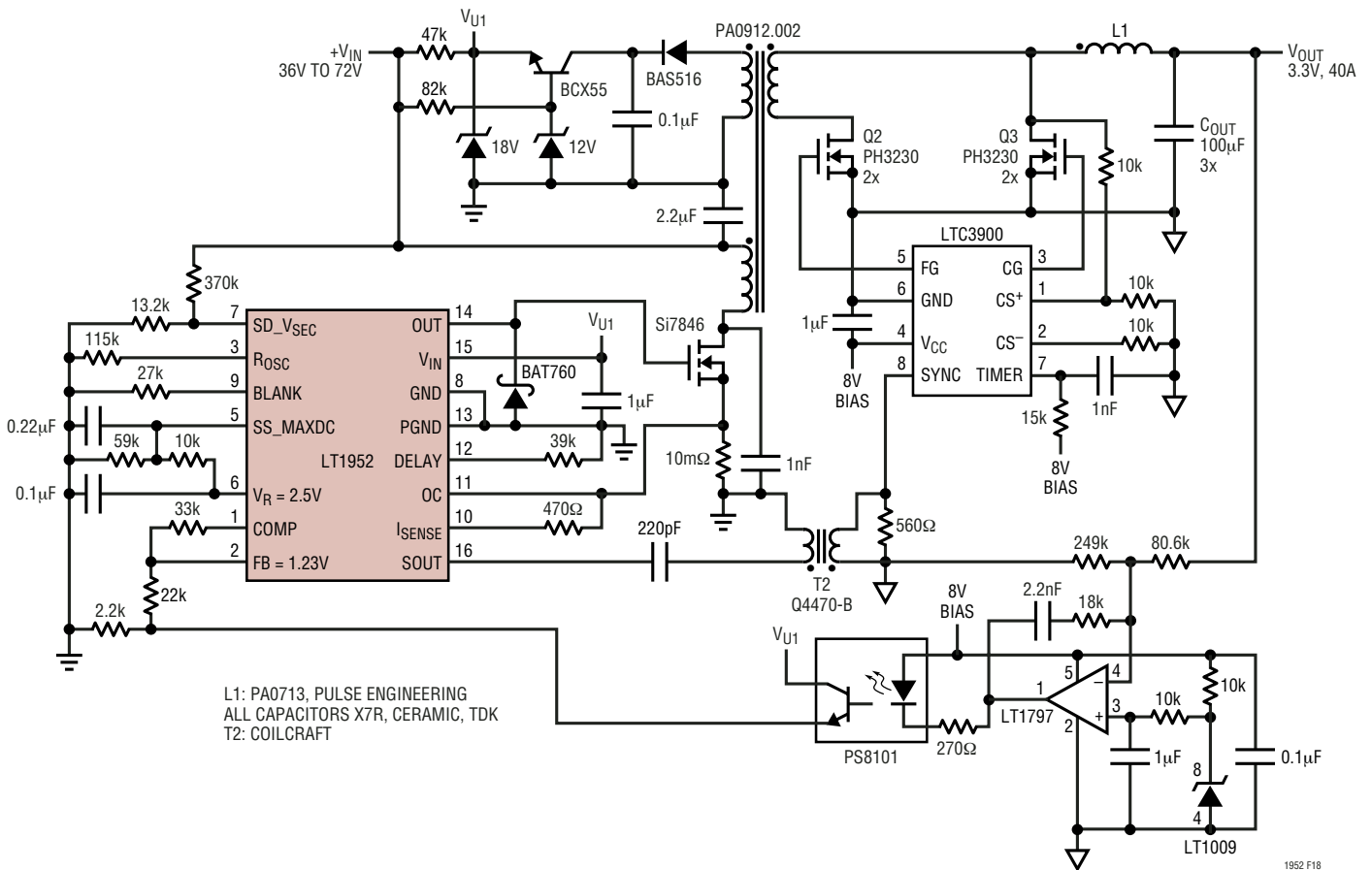

Figure 18. 36V to 72V, 3.3V at 40A Synchronous Forward Converter

APPLICATIONS INFORMATION

Bus Converter: Optimum Output Voltage Tolerance

The Bus Converter applications shown on page 1 and in Figure 16, provide semi-regulated isolated outputs without the need for an optocoupler, optocoupler driver, reference or feedback network. The LT1952 Volt-Second clamp adjusts switch duty cycle inversely proportional to input voltage to provide an output voltage that is regulated against input line variations. Some bus converters use a switch duty cycle limit which causes output voltage variation of typically $\pm 33\%$ over a 2:1 input voltage range. The LT1952 typically provides a $\pm 10\%$ output variation for the same input variation. Typical output tolerance is further improved for the LT1952 by inserting a resistor from the system input voltage to the SS_MAXDC pin (R_x in Figure 19).

The LT1952 electrical specifications for the OUT Max Duty Cycle Clamp show typical switch duty cycle to move from 72% to 33% for a 2x change of input voltage (SS_MAXDC pin = 1.84V). Since output voltage regulation follows $V_{IN} \cdot \text{Duty Cycle}$, a switch duty cycle change of 72% to 36% (for a 2x input voltage change) provides minimal output voltage variation for the LT1952 bus converter. To achieve this, an SS_MAXDC pin voltage increase of 1.09x (36/33) would be required at high input line. A resistor R_x inserted between the SS_MAXDC pin and system input voltage (Figure 19) increases SS_MAXDC voltage as input voltage increases, minimizing output voltage variation over a 2:1 input voltage change.

The following steps determine values for R_x , R_T and R_B

- (1) Program switch duty cycle at minimum system input voltage ($V_{S(MIN)}$)
 - (a) $R_{T(1)} = 10k$ (minimum allowed to still guarantee soft-start pull-down)

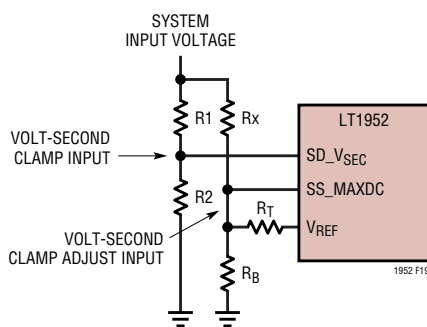

Figure 19. Optimal Programming of Maximum Duty Cycle Clamp for Bus Converter Applications (Adding R_x)

- (b) Select switch duty cycle for the Bus Converter for a given output voltage at $V_{S(MIN)}$ and calculate SS_MAXDC voltage (SS1) (See Applications Information “Programming Maximum Duty Cycle Clamp”)

- (c) Calculate $R_{B(1)} = [SS1/(2.5 - SS1)] \cdot R_{T(1)}$

- (2) Calculate R_x

$$R_x = ([V_{S(MAX)} - V_{S(MIN)}] / [SS1 \cdot (X - 1)]) \cdot R_{THEV(1)}$$

$$R_{THEV(1)} = R_{B(1)} \cdot R_{T(1)} / (R_{B(1)} + R_{T(1)}), X = \text{ideal duty cycle } (V_{S(MAX)}) / \text{actual duty cycle } (V_{S(MIN)})$$

- (3) The addition of R_x causes an increase in the original programmed SS_MAXDC voltage SS1. A new value for $R_{B(1)}$ should be calculated to provide a lower SS_MAXDC voltage (SS2) to correct for this offset.

- (a) $SS2 = SS1 - [(V_{S(MIN)} - SS1) \cdot R_{THEV(1)} / R_x]$

- (b) $R_{B(2)} = [SS2 / (2.5 - SS2)] \cdot R_{T(1)}$

- (4) The thevinin resistance $R_{THEV(1)}$ used to calculate R_x should be re-established for R_T and R_B .

- (a) R_B (final value) = $R_{B(2)} \cdot (R_{THEV(1)} / R_{THEV(2)})$

- (b) R_T (final value) = $R_{T(1)} \cdot (R_{THEV(1)} / R_{THEV(2)})$

where $R_{THEV(2)} = R_{B(2)} \cdot R_{T(1)} / (R_{B(2)} + R_{T(1)})$

Example:

For a Bus Converter running from 36V to 72V input, $V_{S(MIN)} = 36V$, $V_{S(MAX)} = 72V$.

choose $R_{T(1)} = 10k$, SS_MAXDC = SS1 = 1.84V (for 72% duty cycle at $V_{S(MIN)} = 36V$)

$$R_{B(1)} = [1.84V / (2.5 - 1.84V)] \cdot 10k = 28k$$

$$R_{THEV(1)} = [28k \cdot 10k / (28k + 10k)] = 7.4k$$

$$SS_MAXDC \text{ correction} = 36\% / 33\% = 1.09$$

$$R_x = [(72V - 36V) / (1.84 \cdot 0.09)] \cdot 7.4k = 1.6M$$

$$SS2 = 1.84 - [(36V - 1.84) \cdot 7.4k / 1.6M] = 1.682V$$

$$R_{B(2)} = [1.682 / (2.5 - 1.682)] \cdot 10k = 20.6k$$

$$R_{THEV(2)} = [20.6k \cdot 10k / (20.6k + 10k)] = 6.7k$$

$$R_{THEV(1)} / R_{THEV(2)} = 7.4k / 6.7k = 1.104$$

$$R_B \text{ (final value)} = 20.6k \cdot 1.104 = 22.7k \text{ (choose 22.6k)}$$

$$R_T \text{ (final value)} = 10k \cdot 1.104 = 11k$$

PACKAGE DESCRIPTION

GN Package 16-Lead Plastic SSOP (Narrow .150 Inch) (Reference LTC DWG # 05-08-1641)

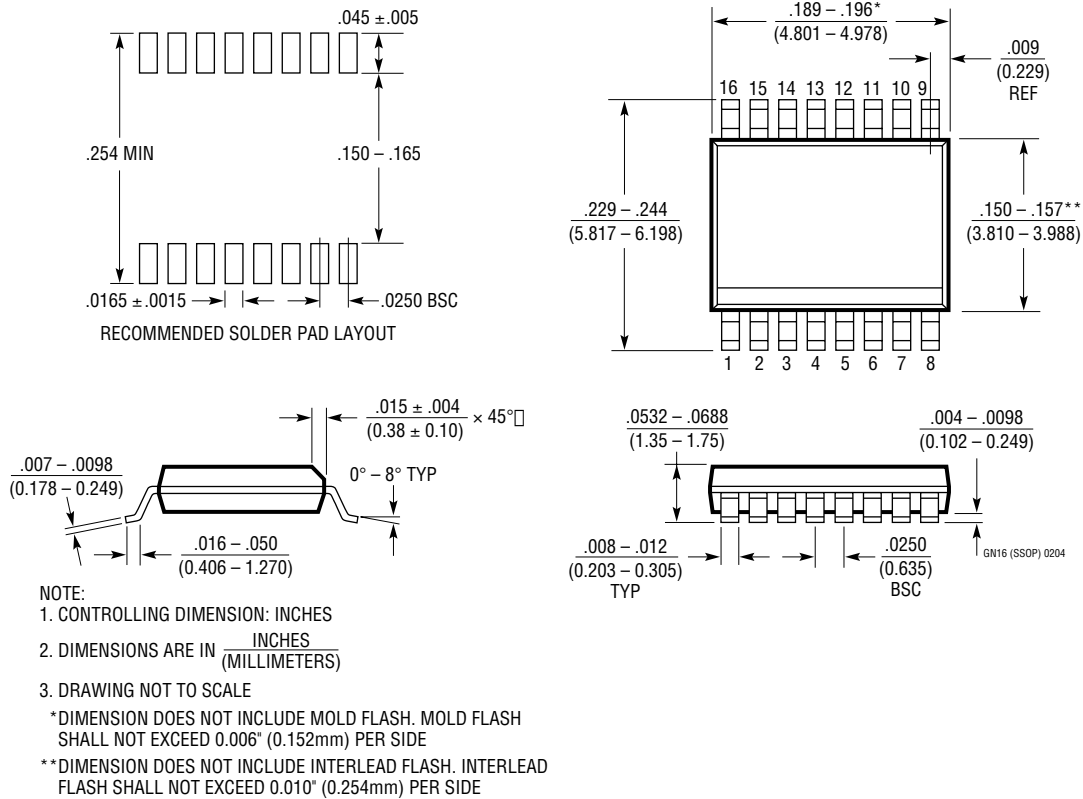

RELATED PARTS

PART NUMBER	DESCRIPTION	COMMENTS
LT1681/LT3781	Synchronous Forward Controllers	High Efficiency 2-Switch Forward Control
LT1698	Secondary Synchronous Rectifier Controller	Use for Isolated Power Supplies, Contains Voltage Margining, Optocoupler Driver, Synchronization Circuit with the Primary Side, Error Amplifier
LT1725	General Purpose Isolated Flyback Controller	Drives External Power MOSFET, Senses Output Voltage Directly from Primary Side Switching — No Optoisolator Required, 16-pin SSOP
LT1950	Single Switch Forward Controller	$3V \leq V_{IN} \leq 25V$, 25W to 500W, Adaptive Max Duty Cycle Clamp, Programmable Slope Compensation, Low 100mV Sense Threshold, 16-Pin SSOP
LTC3722-1/LTC3722-2	Dual Mode Phase Modulated Full-Bridge Controllers	ZVS Full-Bridge Controllers
LTC3723-1/LTC3723-2	Synchronous Push-Pull PWM Controllers	High Efficiency Push-Pull PWM
LTC3803	SOT-23 Flyback Controller	Adjustable Slope Compensation, Internal Soft-Start, 200kHz
LTC3806	Synchronous Flyback Controller	Excellent Cross Regulation, High Efficiency, Multiple Outputs
LTC3900	Synchronous Rectifier Driver for Forward Converters	Use for Isolated Power Supplies, $4.5V \leq V_{IN} \leq 11V$, N-channel Synchronous MOSFET Driver, Programmable Timeout, Reverse Inductor Current Sense, 16-pin SSOP