

Dot Matrix LED Unit for Outdoor Use LT1442M/LT1445M(Lamp Type)

■ Features

- No. of dots : 16X16dots
- Outline dimensions : 160X160mm
- Dot size : $\phi 7.5\text{mm}$
- Dot pitch : 10mm
- Radiation color : Yellow-green+Red(High-luminosity)dichromatic type
- Driving method : Static drive

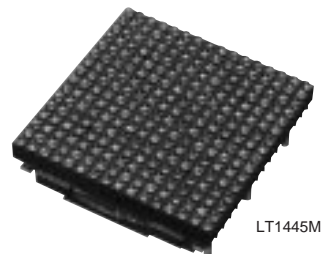

LT1445M

■ Absolute Maximum Ratings

($T_a=25^\circ\text{C}$)

Parameter	Symbol	Rating	Unit
Supply voltage for IC	VCC	5.5	V
Supply voltage for LED	VLED	3.5	V
Input voltage ^{*1}	V _i	5.5	V
Operating temperature	T _{opr}	-10 to +75	°C
Storage temperature	T _{stg}	-20 to +100	°C
Power dissipation	P	35/49	W

*1 V_i<V_{cc} at V_{cc}≤5

Each figure in the table is the one of LT1442M/LT1445M in sequence.

■ Optical Characteristics

($V_{CC}=5\text{V}, V_{LED}=3\text{V}, T_a=25^\circ\text{C}$)

Parameter	Symbol	TYP	Unit
Luminance	Red	MIN. 800/700	cd/m ²
	Yellow-green	MIN. 800/700	
Viewing angle	2 θ ^{1/2}	36/54	°
Peak emission wavelength	Red	660	nm
	Yellow-green	565	

Each figure in the table is the one of LT1442M/LT1445M in sequence.

■ Terminal Functions

Connector	Symbol	Function
Power supply (CN1)	VLED	Supply voltage for LED(+3V)
	VCC	Supply voltage for IC(+5V)
	GND	Ground
Input signal (CN2)	RDATA	Serial data input for red(H=ON, L=OFF)
	GDATA	Serial data input for yellow-green(H=ON, L=OFF)
	LATCH	L: Contents of shift register is transmitted to latch register. H: Contents are latched.
	RENABLE	Controls ON/OFF of red LED (L: LED ON)
	GENABLE	Controls ON/OFF of yellow-green LED (L: LED OFF)
	CLOCK	Clock signal for data transmission in the shift-register.(L→H: serial data is shifted.)
	GND	Ground for signal
Output signal (CN3)	RDATA	Input signal generated through 256-bit shift register or buffer
	GDATA	Input signal generated through 256-bit shift register or buffer
	LATCH	Buffered input signal
	RENABLE	Buffered input signal
	GENABLE	Buffered input signal
	CLOCK	Buffered input signal
	GND	Ground for signal

Each signal is used as input signal for next unit.

* As for the terminal number, refer to the outline dimensions.

■ Electrical Characteristics

($V_{CC}=5\text{V}, V_{LED}=3\text{V}, T_a=25^\circ\text{C}$)

Parameter	Symbol	MIN.	TYP.	MAX.	Unit
Supply voltage for IC	VCC	4.75	5.0	5.25	V
Supply voltage for LED	VLED	2.75	3.0	3.25	V
IC current dissipation	ICC	—	220/280	—	mA
LED current dissipation ^{*1}	I _{LED}	—	9.3/11.5	—	A
Input voltage	V _{IH}	3.5	—	—	V
	V _{IL}	—	—	1.5	V
Input current	I _{IH}	—	—	0.1	μA
	I _{IL}	—	—	0.12	mA
Clock frequency	f _{CLK}	—	—	3.0	MHz

*1 Under the condition that dichromatic all dots are lit.

Each figure in the table is the one of LT1442M/LT1445M in sequence.

■ Timing Chart

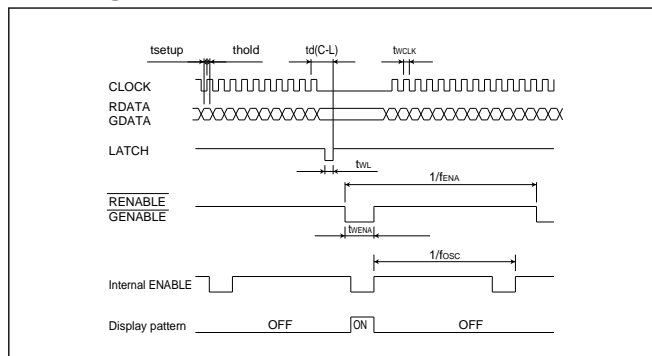

■ Block Diagram

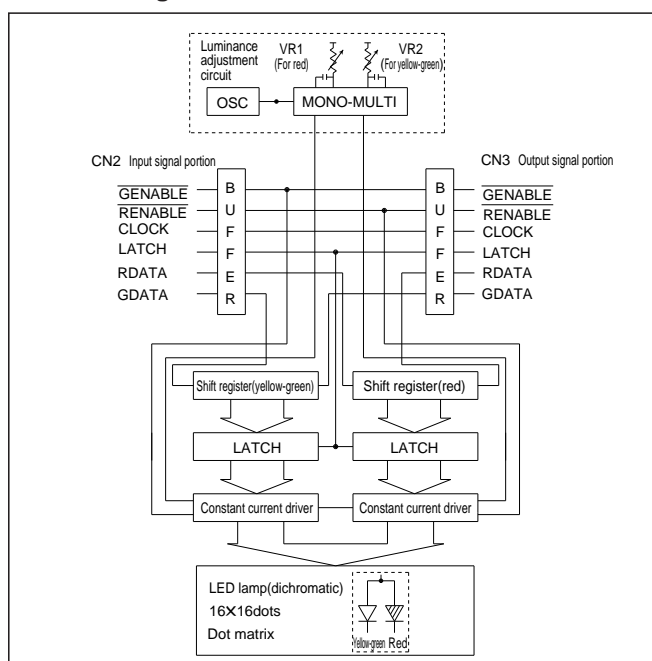

(Notice) • In the absence of confirmation by device specification sheets, SHARP takes no responsibility for any defects that may occur in equipment using any SHARP devices shown in catalogs, data books, etc. Contact SHARP in order to obtain the latest device specification sheets before using any SHARP device.
 (Internet) • Data for sharp's optoelectronic/power device is provided for internet.(Address <http://www.sharp.co.jp/ecg/>)

10

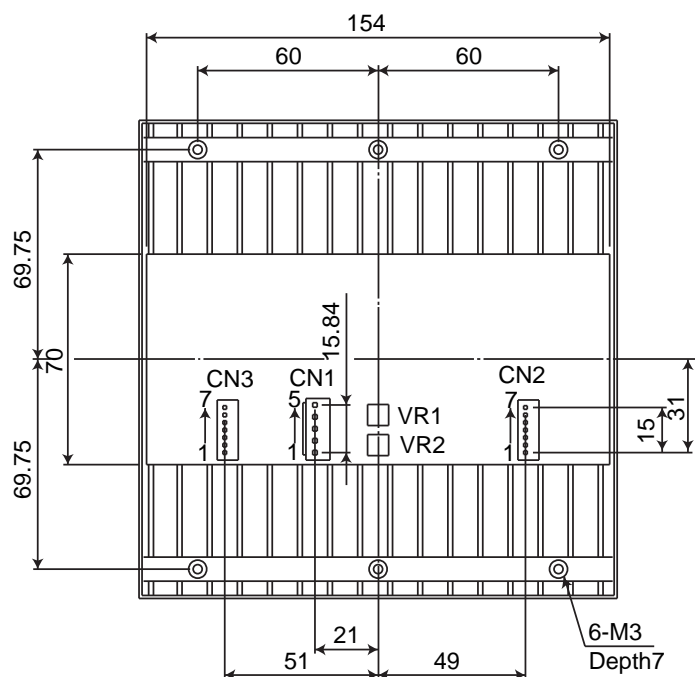
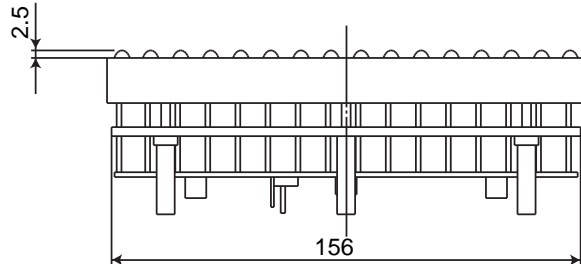
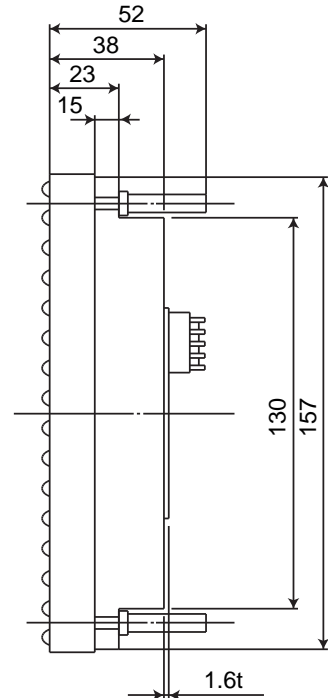
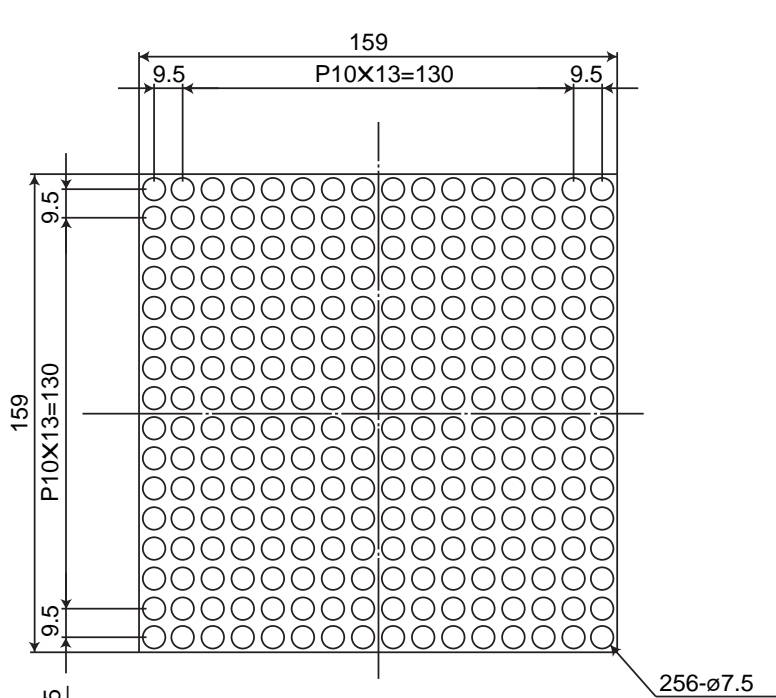

Pin connection

CN1(Power supply)

1	VLED
2	GND
3	VCC
4	GND
5	VLED

CN2(Input signal)

1	GDATA
2	GENABLE
3	LATCH
4	GND
5	CLOCK
6	RENABLE
7	RDATA

CN3(Output signal)

1	GDATA
2	GENABLE
3	LATCH
4	GND
5	CLOCK
6	RENABLE
7	RDATA

LT1442M/LT1445M