

10 Amp Positive Adjustable Voltage Regulator

FEATURES

- *Guaranteed* 0.8% Initial Tolerance
- *Guaranteed* 0.4% Load Regulation
- *Guaranteed* 10 Amp Output Current
- 100% Thermal Limit Burn-in
- 24 Amp Transient Output Current
- Standard Adjustable Pinout
- Operates to 35V

APPLICATIONS

- System Power Supplies
- High Power Linear Regulator
- Battery Chargers
- Power Driver
- Constant Current Regulator

DESCRIPTION

The LT1038 is a three terminal regulator which is capable of providing in excess of 10 amps output current over 1.2V to 32V range. The device is packaged in a standard TO-3 power package, and is plug-in compatible with industry standard adjustable regulators, such as the LM117 and LM138. Also, the LT1038 is a functional replacement for the LM396.

In addition to excellent load and line regulations, the LT1038 is fully protected by current limiting, safe area protection and thermal shutdown. New current limiting circuitry allows transient load currents up to 24 amps to be supplied for 500 μ s without causing the regulator to current limit and drop out of regulation during the transient.

On-chip trimming of initial reference voltage to $\pm 0.8\%$ combined with 0.4% load regulation minimize errors in all high current applications. Further, the LT1038 is manufactured with standard bipolar processing and has Linear Technology's high reliability.

4

5V, 10 Amp Regulator

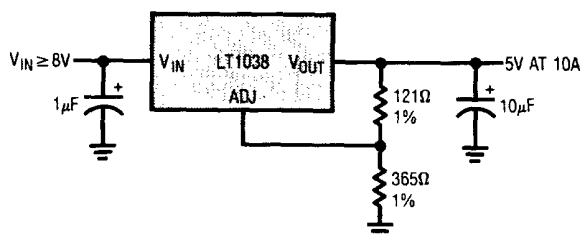

Load Regulation

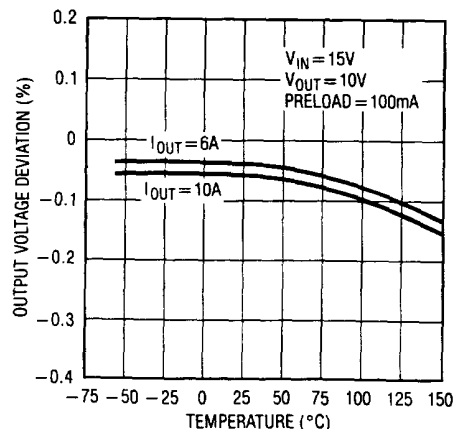

ABSOLUTE MAXIMUM RATINGS

Power Dissipation Internally Limited
 Input to Output Voltage Differential 35V
 Operating Junction Temperature Range
 LT1038M
 Control Circuitry -55°C to 150°C
 Power Transistor -55°C to 200°C
 LT1038C
 Control Circuitry 0°C to 125°C
 Power Transistor 0°C to 175°C
 Storage Temperature -65°C to 150°C
 Lead Temperature (Soldering, 10 sec.) 300°C

PACKAGE/ORDER INFORMATION

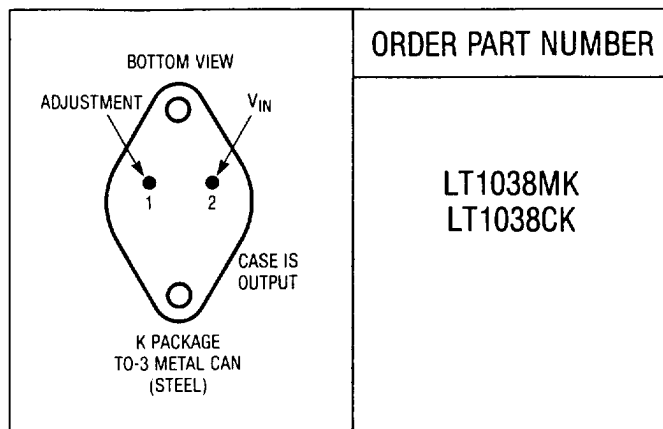

ORDER PART NUMBER

LT1038MK
 LT1038CK

PRECONDITIONING 100% THERMAL LIMIT BURN-IN

ELECTRICAL CHARACTERISTICS (See Note 1)

SYMBOL	PARAMETER	CONDITIONS	LT1038M			LT1038C			UNITS
			MIN	TYP	MAX	MIN	TYP	MAX	
V _{REF}	Reference Voltage	I _{OUT} = 20mA, T _J = 25°C	1.24	1.25	1.26	1.23	1.25	1.275	V
		3V ≤ (V _{IN} - V _{OUT}) ≤ 35V 20mA ≤ I _{OUT} ≤ 10A, P ≤ 75W	1.22	1.25	1.285	1.22	1.25	1.285	V
ΔV _{OUT} / ΔV _{IN}	Line Regulation	3V ≤ (V _{IN} - V _{OUT}) ≤ 35V, I _{OUT} = 20mA (See Note 2) T _A = 25°C		0.005	0.01		0.005	0.02	% / V
				0.02	0.03		0.02	0.03	% / V
ΔV _{OUT} / ΔI _{OUT}	Load Regulation	20mA ≤ I _{OUT} ≤ 10A (See Note 2) T _A = 25°C 3V ≤ (V _{IN} - V _{OUT}) ≤ 35V 3V ≤ (V _{IN} - V _{OUT}) ≤ 35V		0.1	0.4		0.1	0.6	%
				0.3	0.8		0.3	1	%
	Thermal Regulation	T _A = 25°C, 20ms Pulse		0.002	0.005		0.002	0.01	% / W
	Ripple Rejection	V _{OUT} = 10V, f = 120Hz C _{ADJ} = 0 C _{ADJ} = 10μF	60	60	75	60	60	75	dB
I _{ADJ}	Adjust Pin Current			50	100		50	100	μA
ΔI _{ADJ}	Adjust Pin Current Change	20mA ≤ I _{OUT} ≤ 10A 3V ≤ (V _{IN} - V _{OUT}) ≤ 35V		0.2	3		0.2	3	μA
	Minimum Load Current	(V _{IN} - V _{OUT}) = 35V (V _{IN} - V _{OUT}) ≤ 20V		7	20		7	20	mA
I _{SC}	Current Limit	(V _{IN} - V _{OUT}) ≤ 10V DC	10	14		10	14		A
		Transient (0.5ms)	14	22		14	22		A
		(V _{IN} - V _{OUT}) = 30V, T _J = 25°C	1	2		1	2		A
ΔV _{OUT} / ΔTemp	Temperature Stability			1	2		1		%

ELECTRICAL CHARACTERISTICS (See Note 1)

SYMBOL	PARAMETER	CONDITIONS	LT1038M			LT1038C			UNITS
			MIN	TYP	MAX	MIN	TYP	MAX	
$\frac{\Delta V_{OUT}}{\Delta Time}$	Long Term Stability	$T_A = 125^\circ\text{C}$, 1000 Hours		0.3	1		0.3	1	%
e_n	RMS Output Noise (% of V_{OUT})	$T_A = 25^\circ\text{C}$, $10\text{Hz} \leq f \leq 10\text{kHz}$		0.001			0.001		%
Θ_{JC}	Thermal Resistance Junction to Case	Power Transistor Control Circuitry			1 0.5			1 0.5	$^\circ\text{C}/\text{W}$ $^\circ\text{C}/\text{W}$

The ● denotes the specifications which apply over the full operating temperature range.

Note 1: Unless otherwise specified, these specifications apply: $V_{IN} - V_{OUT} = 5\text{V}$ and $I_{OUT} = 5\text{A}$. These specifications are applicable for power dissipations up to 75W. At input-output voltage differentials greater than 10V, achievable output current and power dissipation decrease due to protection circuitry.

Note 2: See thermal regulation specifications for changes in output voltage due to heating effects. Load and line regulation are measured at a constant junction temperature by low duty cycle pulse testing.

TYPICAL PERFORMANCE CHARACTERISTICS

4

Dropout Voltage

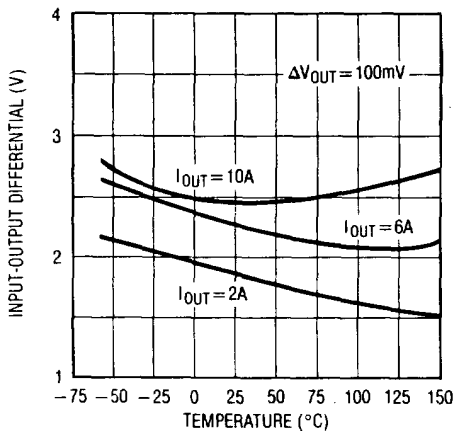

Adjustment Current

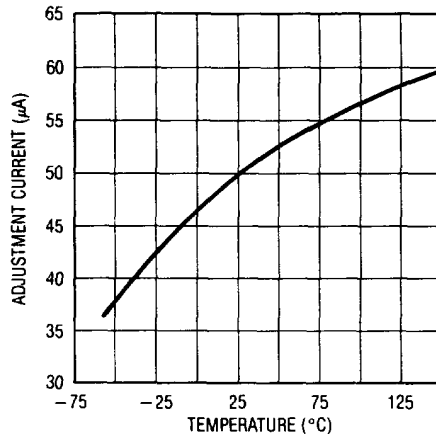

Temperature Stability

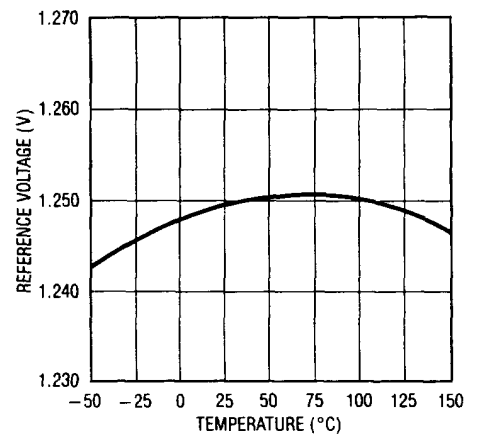

Output Impedance

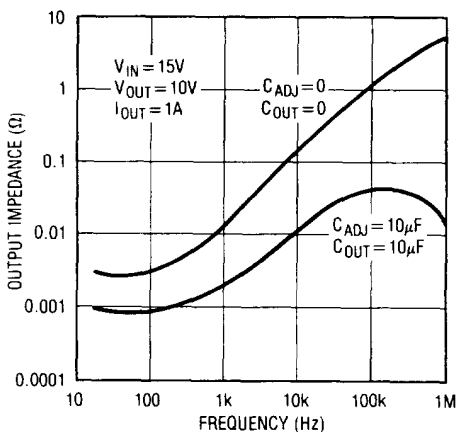

Minimum Operating Current

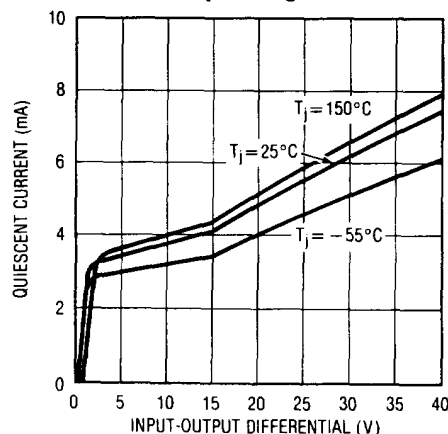

Ripple Rejection

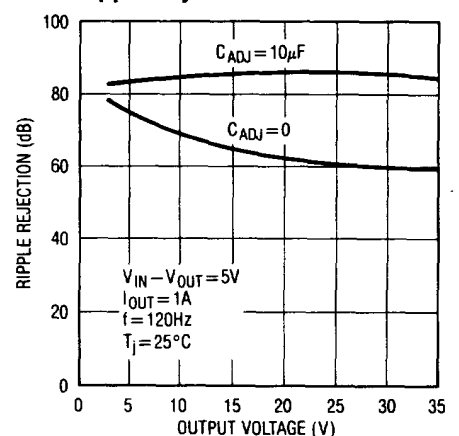

TYPICAL PERFORMANCE CHARACTERISTICS

Ripple Rejection

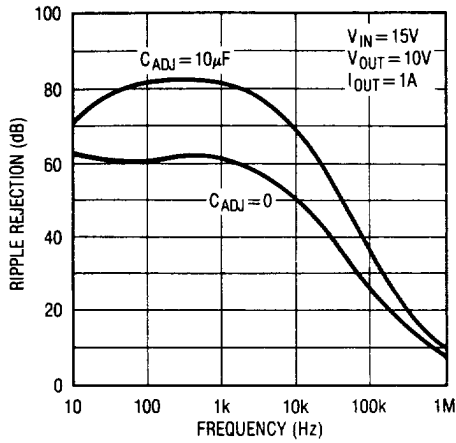

Ripple Rejection

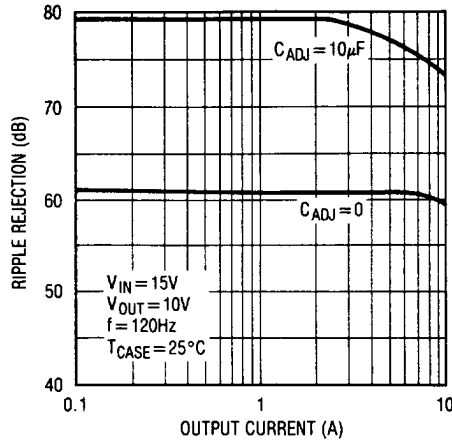

Current Limit

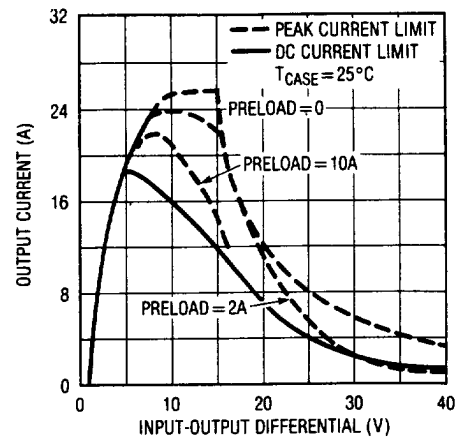

Current Limit

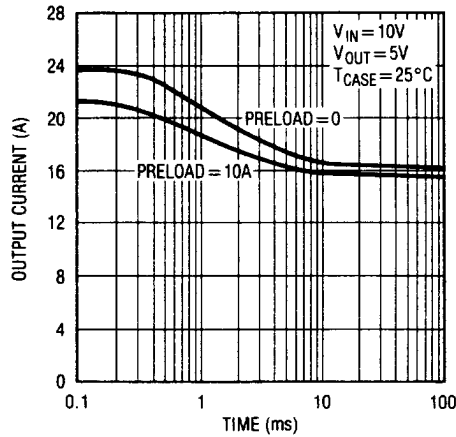

Current Limit

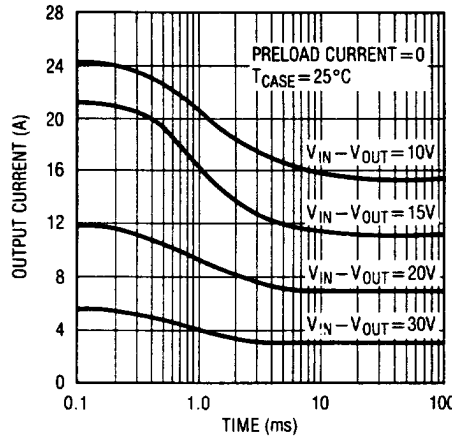

Line Transient Response

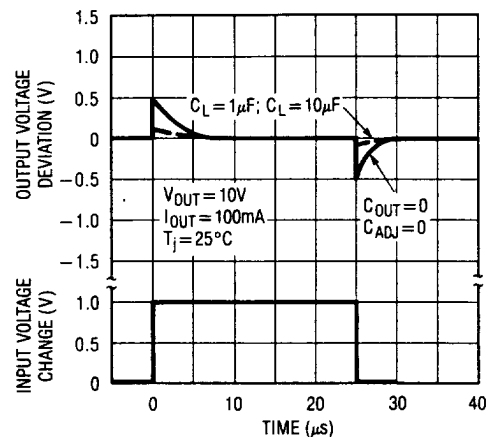

Load Transient Response

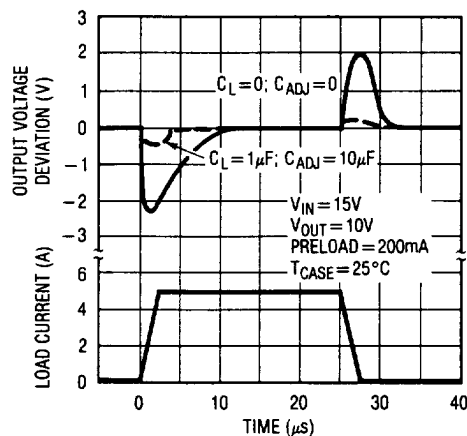

APPLICATIONS INFORMATION

General

The LT1038 develops a 1.25V reference voltage between the output and the adjustment terminal (see Figure 1). By placing a resistor, R1, between these two terminals, a constant current is caused to flow through R1 and down through R2 to set the overall output voltage. Normally this current is the specified minimum load current of 10 or 20mA. Because I_{ADJ} is very small and constant when compared with the current through R1, it represents a small error and can usually be ignored.

Bypass Capacitors

Input bypassing using a 1 μ F tantalum or 25 μ F electrolytic is recommended when the input filter capacitors are more than 5 inches from the device. Improved ripple rejection (80dB) can be accomplished by adding a 10 μ F capacitor from the adjust pin to ground. Increasing the size of the capacitor to 20 μ F will help ripple rejection at low output voltage since the reactance of this capacitor should be small compared to the voltage setting resistor, R2. For improved AC transient response and to prevent the possibil-

ity of oscillation due to unknown reactive load, a 1 μ F capacitor is also recommended at the output. Because of their low impedance at high frequencies, the best type of capacitor to use is solid tantalum.

Protection Diodes

The LT1038 does not require a protection diode from the adjustment terminal to the output (see Figure 2). Improved internal circuitry eliminates the need for this diode when the adjustment pin is bypassed with a capacitor to improve ripple rejection.

If a very large output capacitor is used, such as a 100 μ F shown in Figure 2, the regulator could be damaged or destroyed if the input is accidentally shorted to ground or crowbarred, due to the output capacitor discharging into the output terminal of the regulator. To prevent this, a diode, D1 as shown, is recommended to safely discharge the capacitor.

4

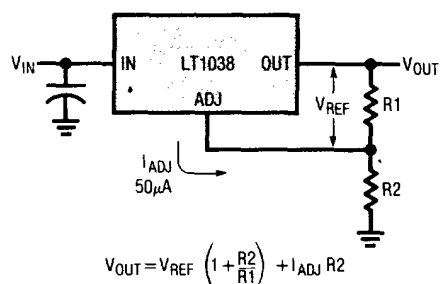

$$V_{OUT} = V_{REF} \left(1 + \frac{R_2}{R_1} \right) + I_{ADJ} R_2$$

Figure 1. Basic Adjustable Regulator

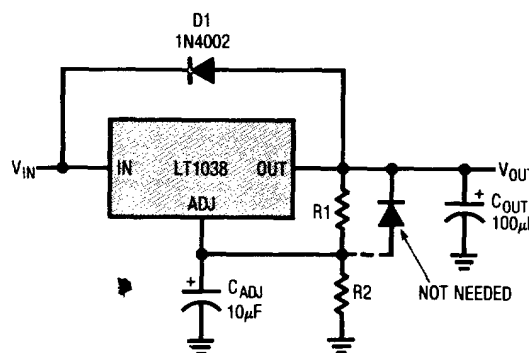

Figure 2

APPLICATIONS INFORMATION

Load Regulation

Because the LT1038 is a three-terminal device, it is not possible to provide true remote load sensing. Load regulation will be limited by the resistance of the wire connecting the regulator to the load. The data sheet specification for load regulation is measured at the bottom of the package. Negative side sensing can be a true Kelvin connection if the bottom of resistor R2 is returned to the negative side of the load. Although it may not be immediately obvious, best load regulation is obtained when the top of the resistor divider, R1, is connected *directly* to the case, *not to the load*. This is illustrated in Figure 3. If

R1 were connected to the load, the effective resistance between the regulator and the load would be

$$R_p \times \left(\frac{R_2 + R_1}{R_1} \right), R_p = \text{Parasitic Line Resistance.}$$

Connected as shown, R_p is not multiplied by the divider ratio. R_p is about 0.004Ω per foot using 16 gauge wire. This translates to 4mV/ft at 1A load current, so it is important to keep the lead between the regulator and the load as short as possible, and use large wire or PC board traces.

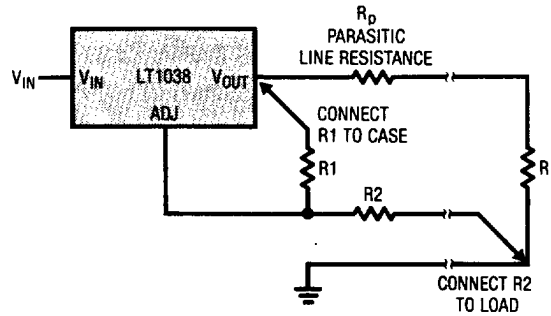
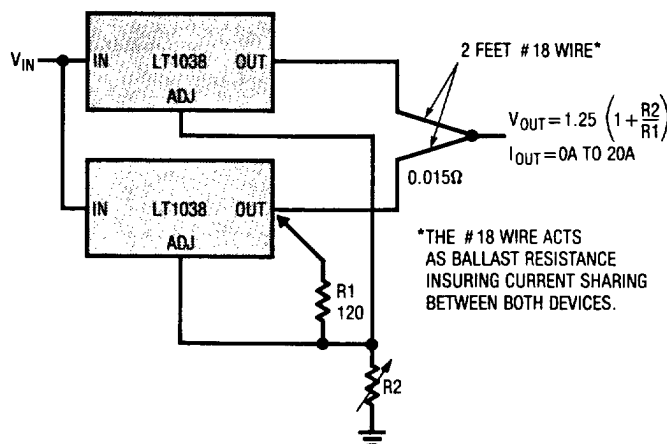

Figure 3. Connections for Best Load Regulation

TYPICAL APPLICATIONS

Paralleling Regulators



TYPICAL APPLICATIONS

10 Amp Variable Regulator*

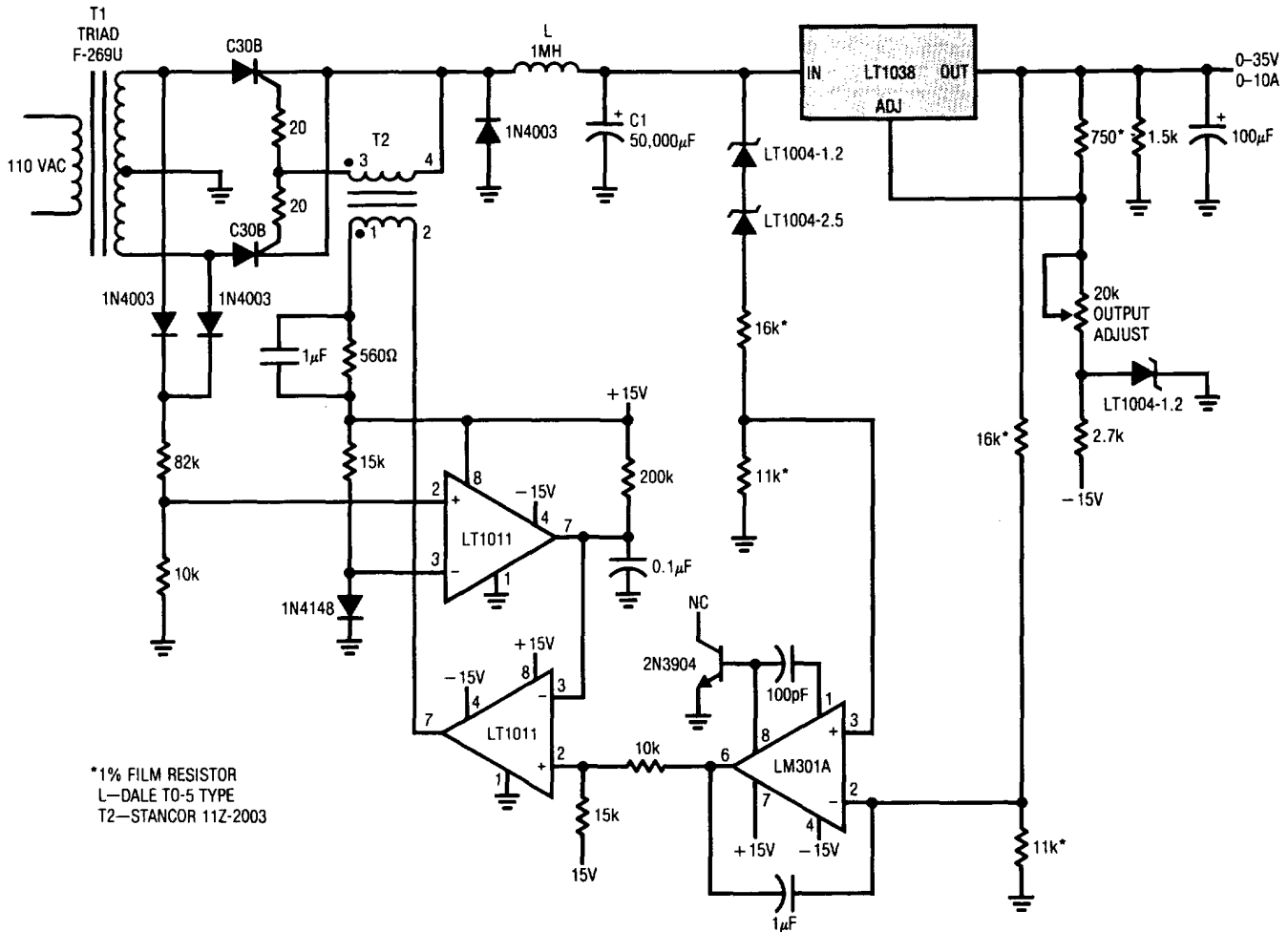

*1% FILM RESISTOR
 L—DALE T0-5 TYPE
 T2—STANCOR 11Z-2003

GENERAL PURPOSE REGULATOR WITH SCR PREREGULATOR TO LOWER POWER DISSIPATION. ABOUT 4V DIFFERENTIAL IS MAINTAINED ACROSS THE LT1038 INDEPENDENT OF OUTPUT VOLTAGE AND LOAD CURRENT.

4

TYPICAL APPLICATIONS

Improving Ripple Rejection

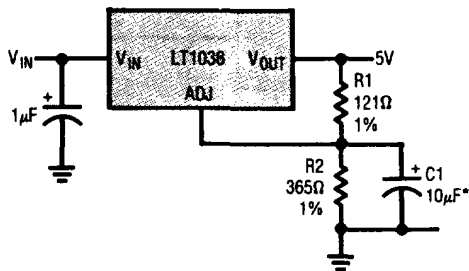

*C1 IMPROVES RIPPLE REJECTION. X_C SHOULD BE SMALL COMPARED TO R2.

1.2V-25V Adjustable Regulator

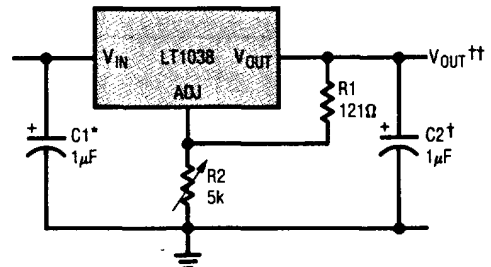

*NEEDED IF DEVICE IS FAR FROM FILTER CAPACITORS
†OPTIONAL—IMPROVES TRANSIENT RESPONSE

$$††V_{OUT} = 1.25V \left(1 + \frac{R2}{R1} \right)$$

5V Regulator with Shutdown

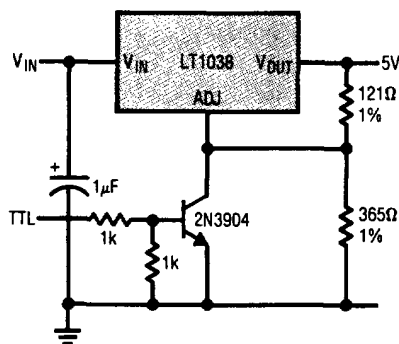

TYPICAL APPLICATIONS

Remote Sensing

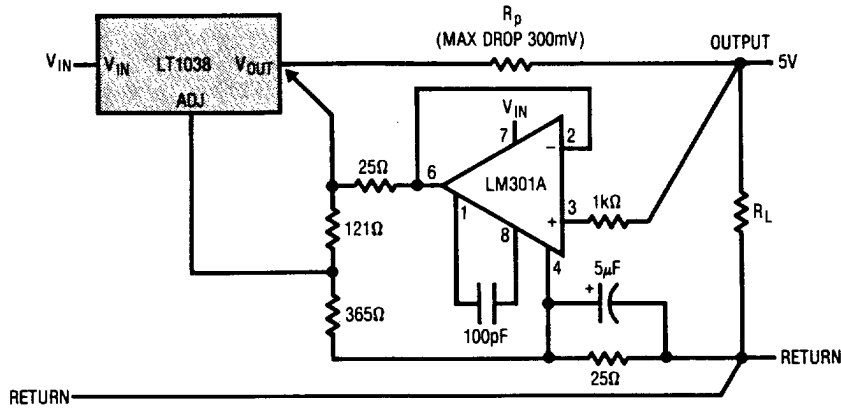

4

Temperature Compensated Lead Acid Battery Charger

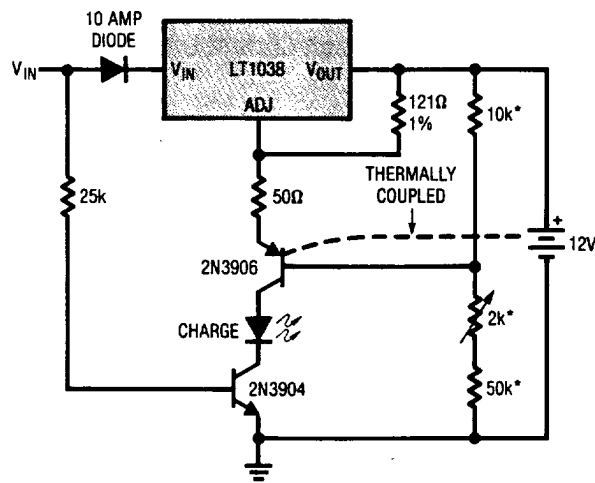

*LOAD ON BATTERY $\approx 200\mu A$ WHEN NOT CHARGING

TYPICAL APPLICATIONS

Lamp Flasher

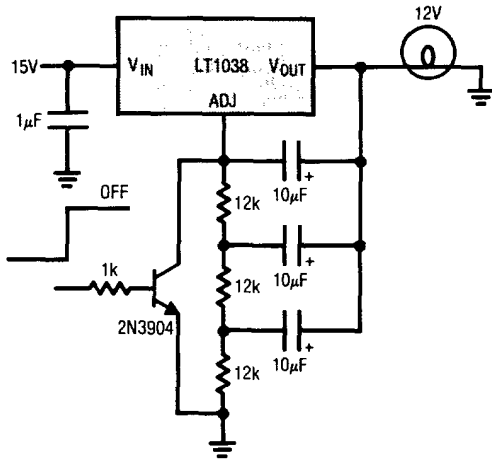

Automatic Light Control

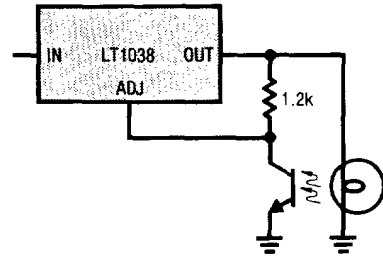

Protected High Current Lamp Driver

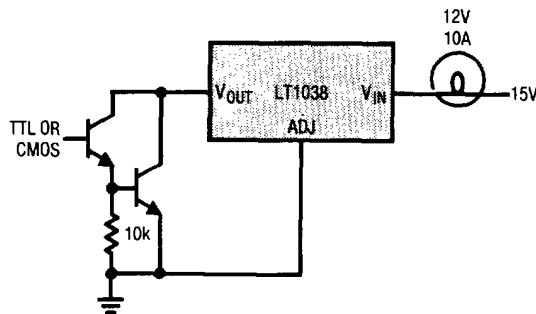

SCHEMATIC DIAGRAM

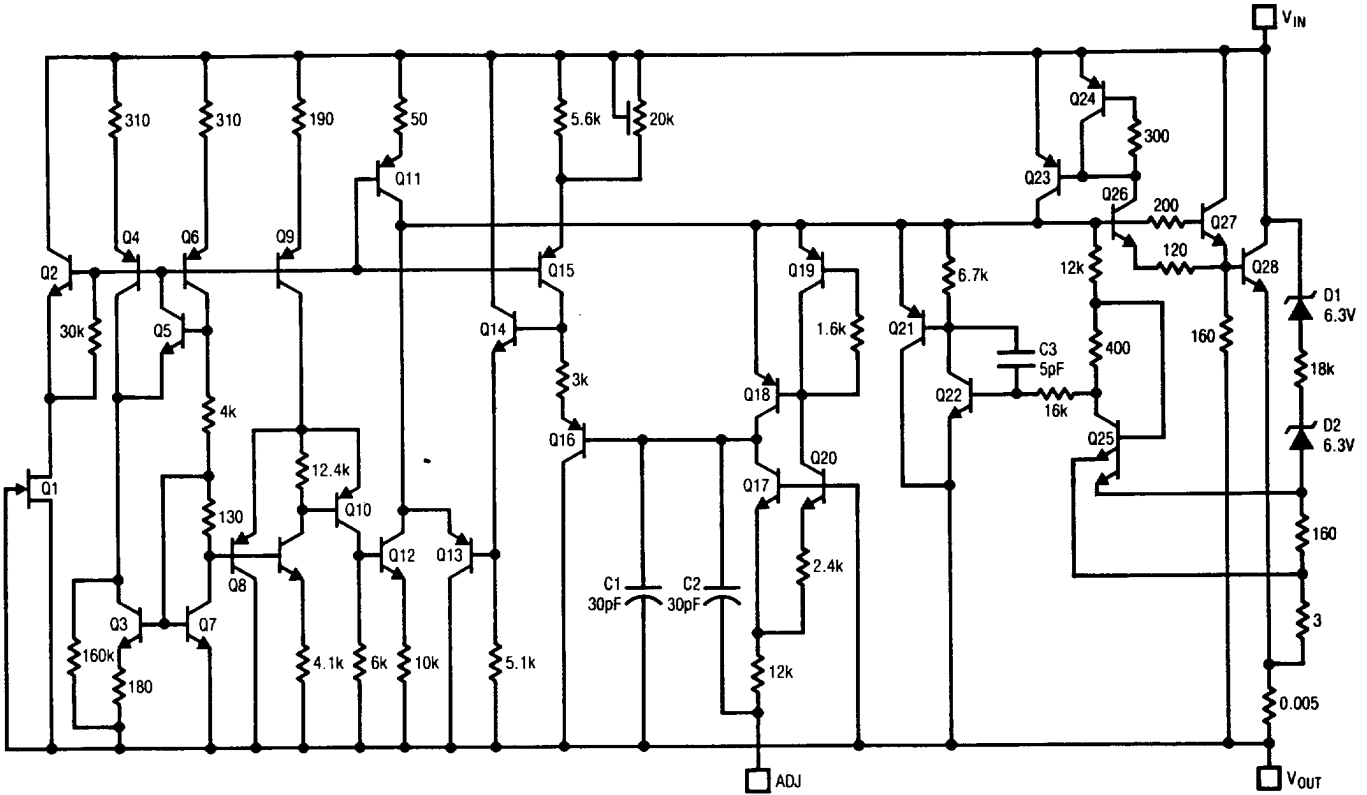

4

PACKAGE DESCRIPTION

K Package TO-3 Steel Metal Can

