

FEATURES

- Pin Compatible with LH0070 and AD581*
- Ultra Low Drift—5ppm/°C Max Slope
- Trimmed Output Voltage
- Operates in Series or Shunt Mode
- Output Sinks and Sources in Series Mode
- Very Low Noise < 1ppm p-p 0.1Hz to 10Hz
- > 100dB Ripple Rejection
- Minimum Input Voltage of 11V

APPLICATIONS

- A to D and D to A Converters
- Precision Regulators
- Digital Voltmeters
- Inertial Navigation Systems
- Precision Scales
- Portable Reference Standard

*See LH0070 Electrical Characteristics table and AD581 cross reference guide.

DESCRIPTION

The LT1031 is a precision 10V reference with ultra low drift and noise, extremely good long term stability, and almost total immunity to input voltage variations. The reference output will both source and sink up to 10mA and can be used as a shunt regulator (two terminal zener) with the same precision characteristics as the three terminal connection. Special care has been taken to minimize thermal regulation effects and temperature induced hysteresis.

The LT1031 reference is based on a buried zener diode structure which eliminates noise and stability problems associated with surface breakdown devices. Further, a subsurface zener exhibits better temperature drift and time stability than even the best band-gap references.

Unique circuit design makes the LT1031 the first three terminal IC reference to offer ultra low drift without the use of high power on-chip heaters. Output voltage is pre-trimmed to 0.05% accuracy.

The LT1031 can be used as a plug-in replacement for the AD581 and LH0070*, with improved electrical and thermal performance.

3

Basic Positive and Negative Connections

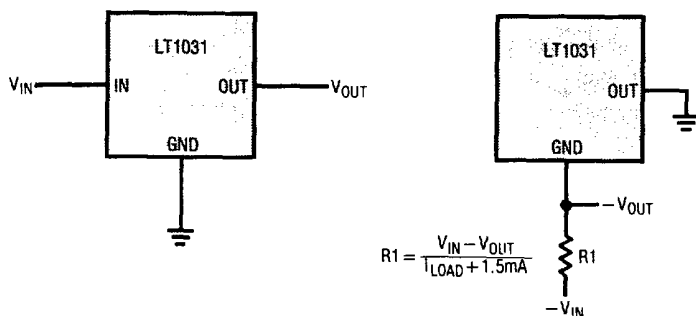

Distribution of Output Accuracy

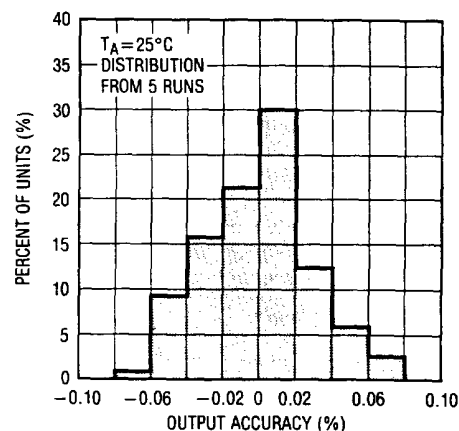

ABSOLUTE MAXIMUM RATINGS

Input Voltage	40V
Input-Output Voltage Differential	35V
Output to Ground Voltage (Shunt Mode Current Limit)	16V
Trim Pin to Ground Voltage	
Positive	Equal to V_{OUT}
Negative	-20V
Output Short Circuit Duration	
$V_{IN} = 35V$	10 sec
$V_{IN} \leq 20V$	Indefinite
Operating Temperature Range	
LT1031 (Mil)	-55°C to 125°C
LT1031 (Comm)	0°C to 70°C
Storage Temperature Range	-65°C to 150°C
Lead Temperature (Soldering, 10 sec.)	300°C

PACKAGE/ORDER INFORMATION

	ORDER PART NUMBER
	LH0070-0H LH0070-1H LH0070-2H LT1031BMH LT1031CMH LT1031DMH LT1031BCH LT1031CCH LT1031DCH

ELECTRICAL CHARACTERISTICS LT1031

$V_{IN} = 15V$, $I_{OUT} = 0$, $T_A = 25^\circ C$, Mil or Comm version, unless otherwise noted

SYMBOL	PARAMETER	CONDITIONS	LT1031			UNITS
			MIN	TYP	MAX	
V_R	Output Voltage (Note 1)	LT1031B	9.995	10.000	10.005	V
		LT1031C	9.990	10.000	10.010	V
		LT1031D	9.980	10.000	10.020	V
$\frac{\Delta V_R}{\Delta T}$	Output Voltage Temperature Coefficient (Note 2)	$T_{MIN} \leq T_J \leq T_{MAX}$				
		LT1031B		3	5	ppm/°C
		LT1031C		6	15	ppm/°C
		LT1031D		10	25	ppm/°C
$\frac{\Delta V_R}{\Delta V_{IN}}$	Line Regulation (Note 3)	$11.5V \leq V_{IN} \leq 14.5V$		1	4	ppm/V
		$14.5V \leq V_{IN} \leq 40V$		0.5	2	ppm/V
$\frac{\Delta V_R}{\Delta I_O}$	Load Regulation (Sourcing Current)	$0 \leq I_{OUT} \leq 10mA$ (Note 3)		12	25	ppm/mA
					40	ppm/mA
$\frac{\Delta V_R}{\Delta I_O}$	Load Regulation (Shunt Mode)	$1.7mA \leq I_{SHUNT} \leq 10mA$ (Notes 3, 4)		50	100	ppm/mA
					150	ppm/mA
I_O	Series Mode Supply Current			1.2	1.7	mA
					2.0	mA
I_{MIN}	Shunt Mode Minimum Current	V_{IN} is Open		1.1	1.5	mA
					1.7	mA
	Output Short Circuit Current	$11V \leq V_{IN} \leq 35V$		30		mA
	Minimum Input Voltage (Note 6)	$I_{OUT} \leq 1mA$		10.8	11.0	V
e_n	Output Voltage Noise	$0.1Hz \leq f \leq 10Hz$ $0.1Hz \leq f \leq 10kHz$		6		$\mu Vp-p$
				11		$\mu Vrms$
$\frac{\Delta V_R}{\Delta Time}$	Long Term Stability of Output Voltage	$\Delta t = 1000$ Hrs Non-Cumulative		15		ppm
					5	ppm
	Temperature Hysteresis of Output	$\Delta T = 50^\circ C$				ppm

ELECTRICAL CHARACTERISTICS LH0070

V_{IN} = 15V, R_L = 10kΩ, -55°C ≤ T_A ≤ +125°C unless otherwise noted

SYMBOL	PARAMETER	CONDITIONS	MIN	TYP	MAX	UNITS
V _R	Output Voltage	T _A = 25°C		10.000		V
ΔV _R	Output Accuracy -0, -1 -2	T _A = 25°C		±0.03 ±0.02	±0.1 ±0.05	% %
ΔV _R	Output Accuracy -0, -1 -2	T _A = -55°C, 125°C	●		±0.3 ±0.2	% %
$\frac{\Delta V_R}{\Delta T}$	Output Voltage Change with Temperature -0 -1 -2	Note 5	● ● ●	±0.02 ±0.01	±0.2 ±0.1 ±0.04	% % %
$\frac{\Delta V_R}{\Delta V_{IN}}$	Line Regulation -0, -1 -2	13V ≤ V _{IN} ≤ 33V, T _A = 25°C		0.006 0.006	0.1 0.03	% %
	Input Voltage Range		●	11.4	40	V
$\frac{\Delta V_R}{\Delta I_O}$	Load Regulation	0mA ≤ I _{OUT} ≤ 5mA	●	0.01	0.03	%
I _Q	Quiescent Current	13V ≤ V _{IN} ≤ 33V	●	1.2	5	mA
$\frac{\Delta I_Q}{\Delta V_{IN}}$	Change in Quiescent Current	ΔV _{IN} = 20V from 13V to 33V	●	0.1	1.5	mA
e _n	Output Noise Voltage			6		μVp-p
	Ripple Rejection	f = 120Hz	●	0.001		%/Vp-p
r _O	Output Resistance		●	0.2	0.6	Ω
$\frac{\Delta V_Z}{\Delta \text{Time}}$	Long Term Stability -0, -1 -2	T _A = 25°C (Note 7)			±0.2 ±0.05	%/Yr %/Yr

The ● denotes the specifications which apply over the full operating temperature range.

Note 1: Output voltage is measured immediately after turn-on. Changes due to chip warm-up are typically less than 0.005%.

Note 2: Temperature coefficient is measured by dividing the change in output voltage over the temperature range by the change in temperature. Separate tests are done for hot and cold; T_{MIN} to 25°C, and 25°C to T_{MAX}. **Incremental slope is also measured at 25°C.** For LT1031BMH, the 5ppm/°C drift specification is for -25°C to 85°C. Drift over the full -55°C to +125°C range is guaranteed to 7ppm/°C.

Note 3: Line and load regulation are measured on a pulse basis. Output changes due to die temperature change must be taken into account separately. Package thermal resistance is 150°C/W.

Note 4: Shunt mode regulation is measured with the input open. With the input connected, shunt mode current can be reduced to 0mA. Load regulation will remain the same.

Note 5: Temperature drift is guaranteed from -25°C to +85°C on LH0070.

Note 6: See curve for guaranteed minimum V_{IN} versus I_{OUT}.

Note 7: Guaranteed by design.

CROSS REFERENCE

The following cross reference guide may be used to select LT1031 grades which meet or exceed output voltage, temperature drift, load and line regulation, and output current specifications of the AD581 reference. Parameters such as noise, hysteresis, and long term stability will be significantly better for all LT1031 grades compared to the AD581.

Cross Reference Guide—LT1031 to AD581

AD581J	order	LT1031DCH
AD581K	order	LT1031CCH
AD581L	order	LT1031BCH
AD581S	order	LT1031DMH
AD581T	order	LT1031CMH
AD581U	order	LT1031BMH

TYPICAL PERFORMANCE CHARACTERISTICS

Ripple Rejection

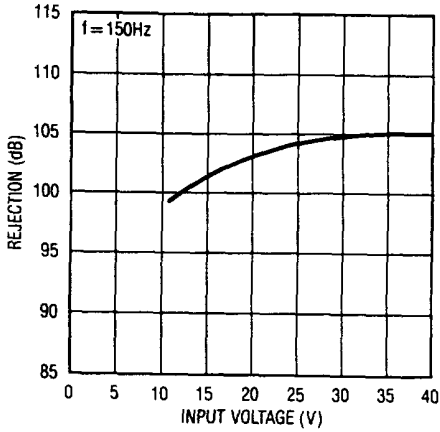

Ripple Rejection

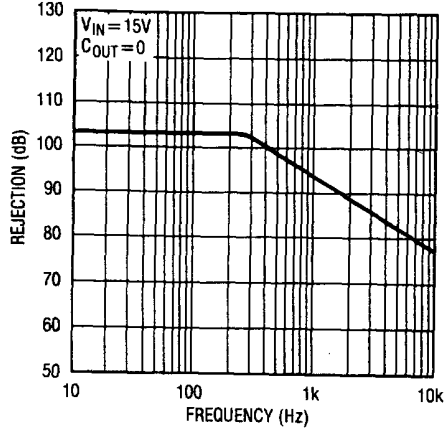

Minimum Input Voltage

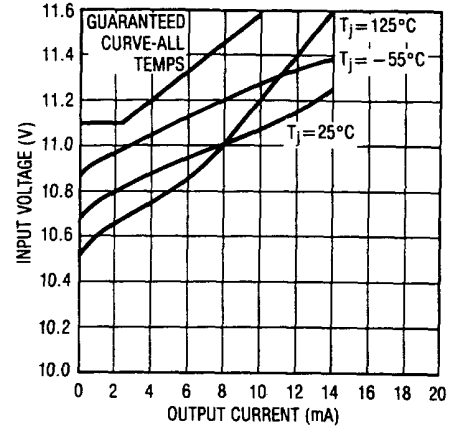

Start-Up (Series Mode)

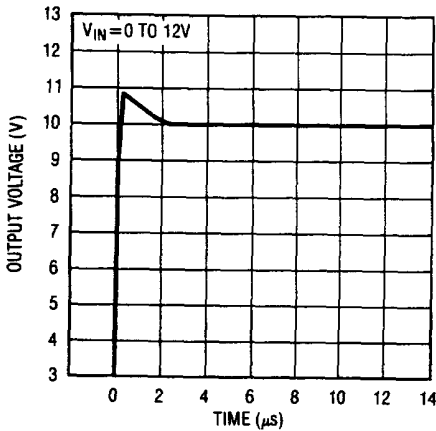

Start-Up (Shunt Mode)

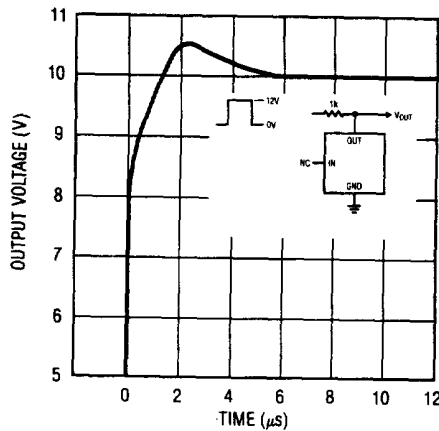

Output Voltage Noise Spectrum

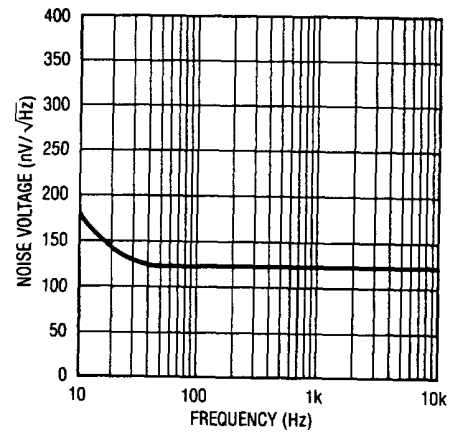

Output Voltage Noise

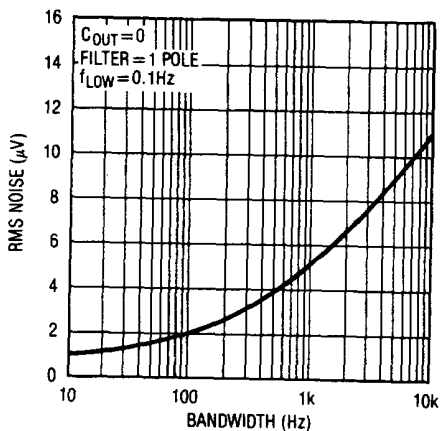

Load Regulation

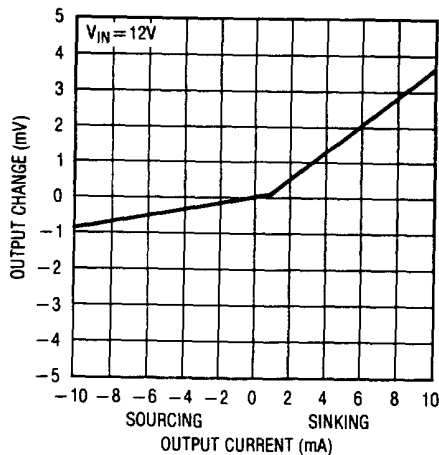

Output Voltage Temperature Drift

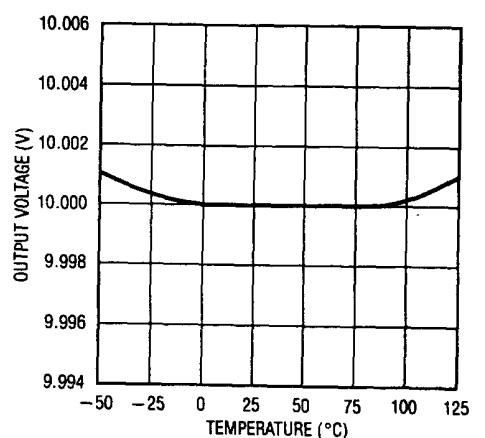

TYPICAL PERFORMANCE CHARACTERISTICS

Input Supply Current

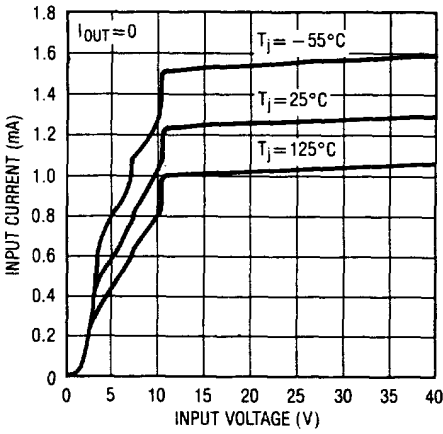

Shunt Characteristics

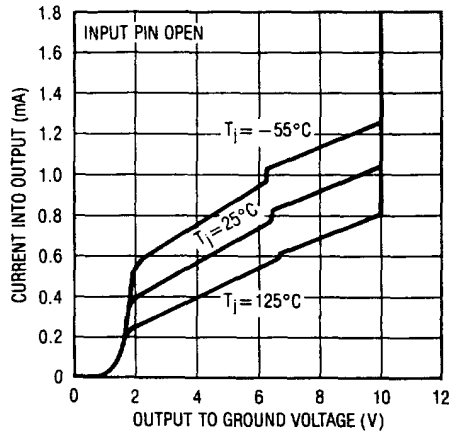

Shunt Mode Current Limit

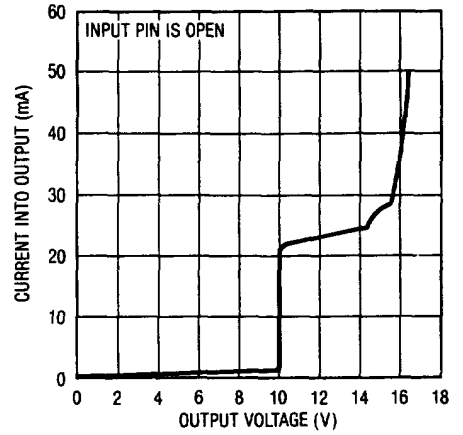

Thermal Regulation

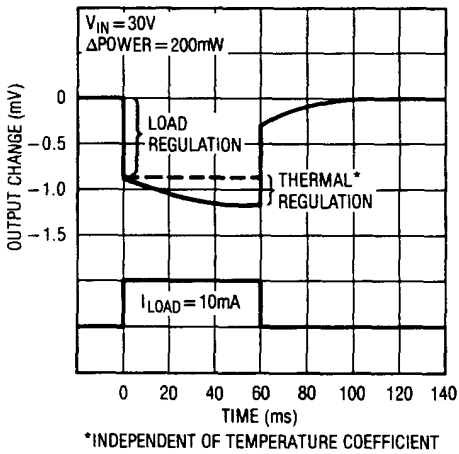

Load Transient Response $C_{LOAD}=0$

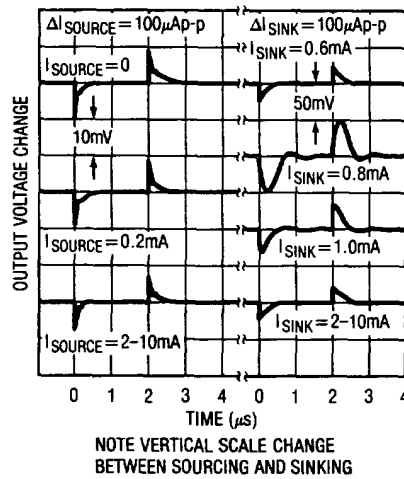

Load Transient Response $C_{LOAD}=1000\text{pF}$

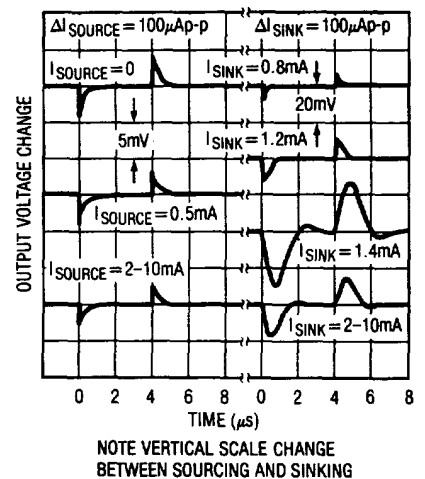

Output Noise 0.1Hz to 10Hz

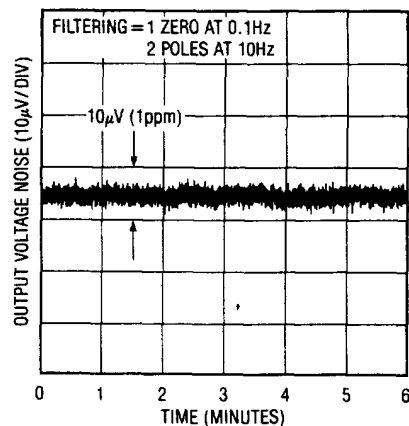

3

APPLICATIONS INFORMATION

Trimming Output Voltage

The LT1031 output can be trimmed by driving the ground pin. The suggested method is shown in the accompanying figure. A 5Ω resistor is inserted in series with the ground pin and the top of the resistor is supplied current from a trim potentiometer. This technique requires fairly high trim current—up to 1.5mA from the LT1031 or 3.5mA from the -15V supply, but it is necessary to maintain low drift in the reference. Ground pin current changes in the LT1031 (with temperature) could be as high as 4μA/°C. This, coupled with the 5Ω external resistor, creates up to 2ppm/°C drift in the reference (5Ω × 4μA/°C = 20μV/°C = 2ppm/°C). If induced drift higher than this can be tolerated, all resistor values in the trim circuit can be raised proportionately to reduce current drain.

Output Voltage Trimming

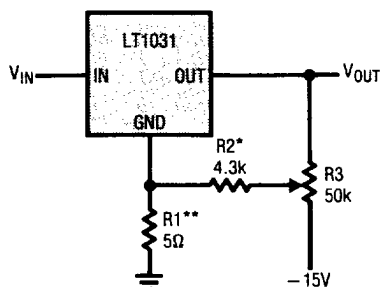

* CAN BE INCREASED TO 5.6k FOR
LT1031B AND LH0070-2
** INCREASE TO 10Ω FOR LT1031D

Effect of Reference Drift on System Accuracy

A large portion of the temperature drift error budget in many systems is the system reference voltage. This graph indicates the maximum temperature coefficient allowable if the reference is to contribute no more than ½LSB error to the overall system performance. The example shown is a 12-bit system designed to operate over a temperature range from 25°C to 65°C. Assuming the system calibration is performed at 25°C, the temperature span is 40°C. It can be seen from the graph that the temperature coefficient of the reference must be no worse than 3ppm/°C if it is to contribute less than ½LSB error. For this reason, the LT1031 has been optimized for low drift.

Maximum Allowable Reference Drift

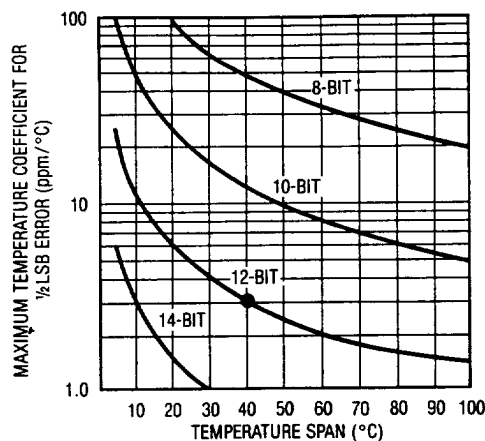

Capacitive Loading and Transient Response

The LT1031 is stable with all capacitive loads, but for optimum settling with load transients, output capacitance should be under 1000pF. The output stage of the reference is class AB with a fairly low idling current. This makes transient response worst-case at light load currents. Because of internal current drain on the output, actual worst-case occurs at I_{LOAD} = 1.4mA (sinking). Significantly better load transient response is obtained by moving slightly away from these points. See Load Transient Response curves for details. In general, best transient response is obtained when the output is sourcing current. In critical applications, a 10μF solid tantalum capacitor with several ohms in series provides optimum output bypass.

Kelvin Connections

Although the LT1031 does not have true force/sense capability at its outputs, significant improvements in ground loop and line loss problems can be achieved with proper hook-up. In series mode operation, the ground pin of the LT1031 carries only ≈ 1mA and can be used as a sense line, greatly reducing ground loop and loss problems on the low side of the reference. The high side supplies load current so line resistance must be kept low. Twelve feet of #22 gauge hook up wire or 1 foot of 0.025 inch printed circuit trace will create 2mV loss at 10mA output current. This is equivalent to 1LSB in a 10V, 12-bit system.

APPLICATIONS INFORMATION

The circuits below show proper hook up to minimize errors due to ground loops and line losses. Losses in the output lead can be greatly reduced by adding a PNP boost transistor if load currents are 5mA or higher. R2 can be added to further reduce current in the output sense lead.

Standard Series Mode

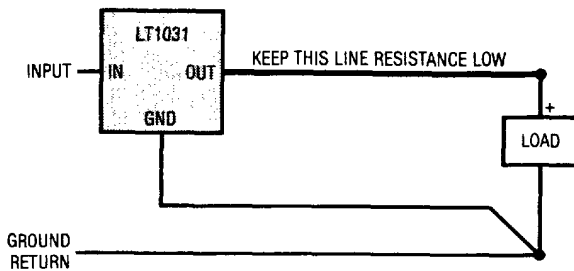

Series Mode with Boost Transistor

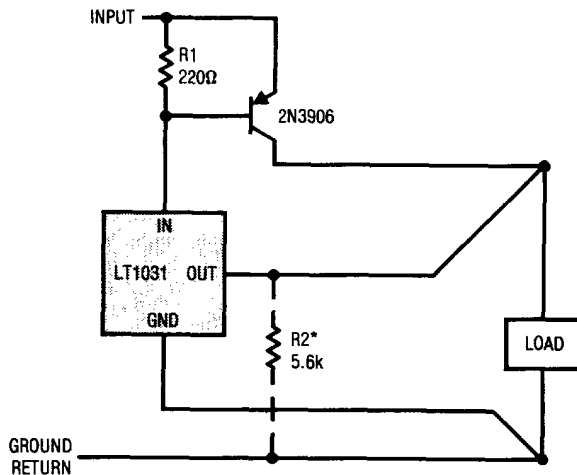

*OPTIONAL—REDUCES CURRENT IN OUTPUT SENSE LEAD

Effects of Air Movement on Low Frequency Noise

The LT1031 has very low noise because of the buried zener used in its design. In the 0.1Hz to 10Hz band, peak-to-peak noise is about 0.5ppm of the DC output. To achieve this low noise, however, care must be taken to shield the reference from ambient air turbulence. Air

movement can create noise because of thermoelectric differences between IC package leads (especially kovar lead TO-5) and printed circuit board materials and/or sockets. Power dissipation in the reference, even though it rarely exceeds 20mW, is enough to cause small temperature gradients in the package leads. Variations in thermal resistance, caused by uneven air flow, create differential lead temperatures, thereby causing thermoelectric voltage noise at the output of the reference. The XY plotter trace shown below dramatically illustrates this effect. The first half of the plot was done with the LT1031 shielded from ambient air with a small foam cup. The cup was then removed for the second half of the trace. Ambient in both cases was a lab environment with no excessive air turbulence from air conditioners, opening/closing doors, etc. Removing the foam cup increases the output noise by almost an order of magnitude in the 0.01Hz to 1Hz band! The kovar leads of the TO-5 (H) package are the primary culprit. Alloy 42 and copper lead frames used on dual-in-line packages are not nearly as sensitive to thermally generated noise because they are intrinsically matched.

There is nothing magical about foam cups—any enclosure which blocks air flow from the reference will do. Smaller enclosures are better since they do not allow the build-up of internally generated air movement. Naturally, heat generating components external to the reference itself should not be included inside the enclosure.

Noise Induced by Air Turbulence (TO-5 Package)

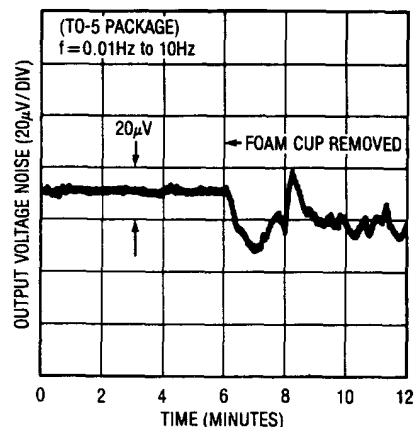

3

APPLICATION CIRCUITS

Negative Series Reference

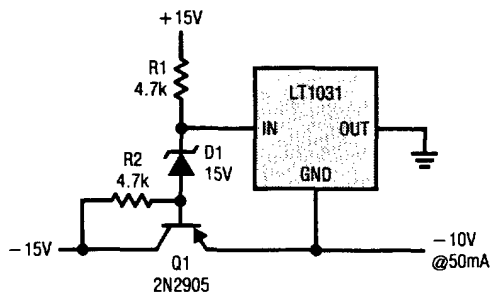

Boosted Output Current With No Current Limit

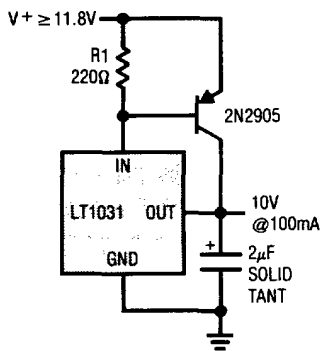

Boosted Output Current With Current Limit

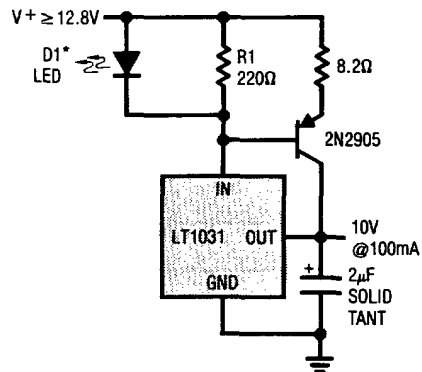

*GLOWS IN CURRENT LIMIT.
DO NOT OMIT.

APPLICATION CIRCUITS

Handling Higher Load Currents

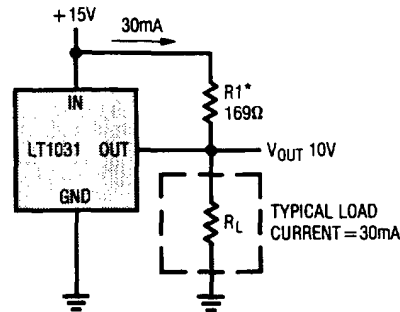

*SELECT R1 TO DELIVER TYPICAL LOAD CURRENT. LT1031 WILL THEN SOURCE OR SINK AS NECESSARY TO MAINTAIN PROPER OUTPUT. DO NOT REMOVE LOAD AS OUTPUT WILL BE DRIVEN UNREGULATED HIGH. LINE REGULATION IS DEGRADED IN THIS APPLICATION.

3

Strain Gauge Conditioner for 350Ω Bridge

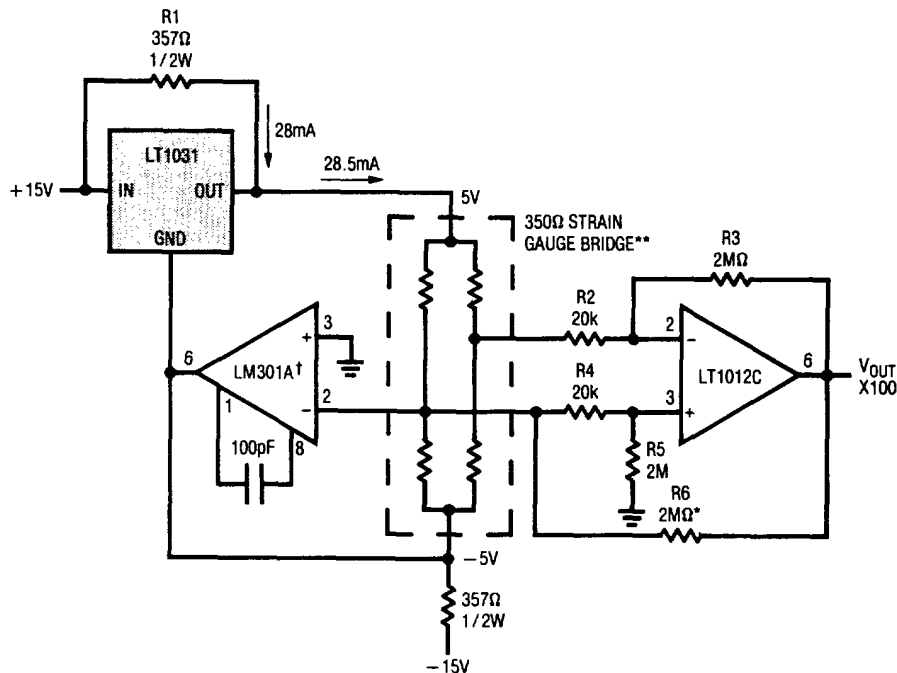

*THIS RESISTOR PROVIDES POSITIVE FEEDBACK TO THE BRIDGE TO ELIMINATE LOADING EFFECT OF THE AMPLIFIER. EFFECTIVE Z_{IN} OF AMPLIFIER STAGE IS $\geq 1M\Omega$. IF R2-R5 ARE CHANGED, SET R6 = R3.

**BRIDGE IS ULTRA LINEAR WHEN ALL LEGS ARE ACTIVE, TWO IN COMPRESSION AND TWO IN TENSION, OR WHEN ONE SIDE IS ACTIVE WITH ONE COMPRESSED AND ONE TENSIONED LEG.

†OFFSET AND DRIFT OF LM301A ARE VIRTUALLY ELIMINATED BY DIFFERENTIAL CONNECTION OF LT1012C.

APPLICATION CIRCUITS

Ultra Linear Platinum Temperature Sensor*

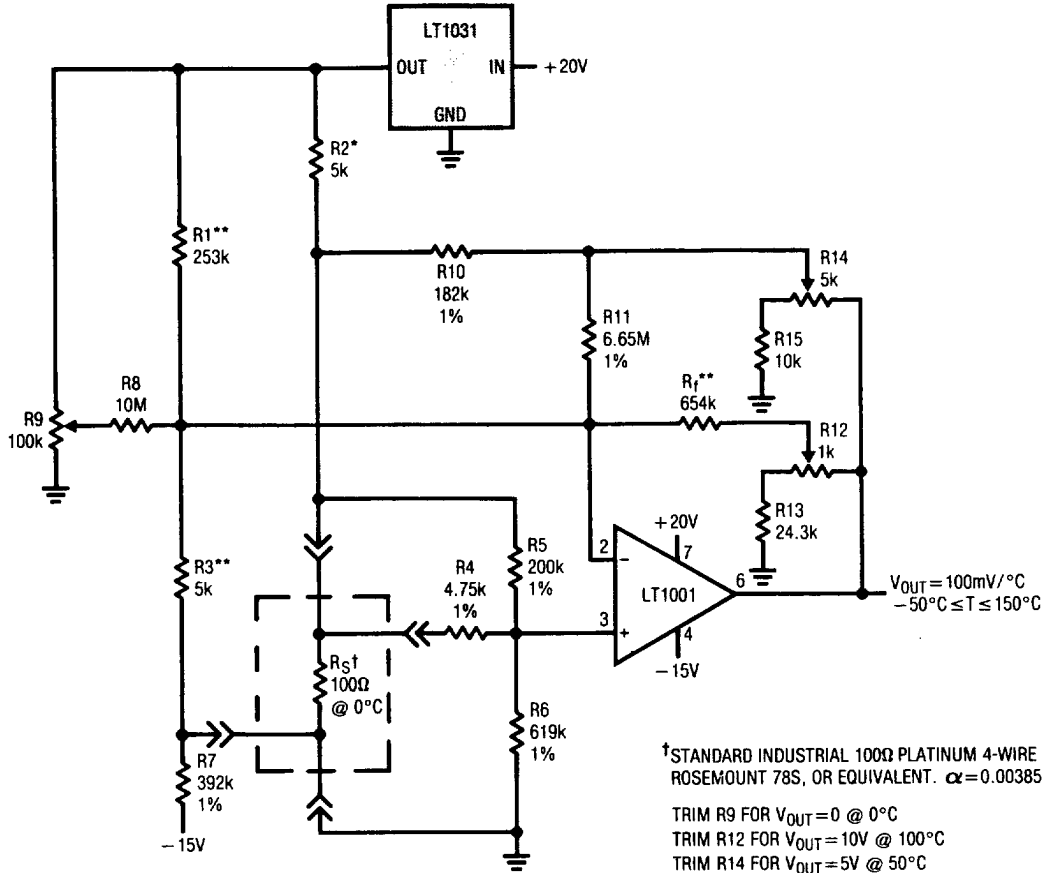

†STANDARD INDUSTRIAL 100Ω PLATINUM 4-WIRE SENSOR, ROSEMOUNT 78S, OR EQUIVALENT. $\alpha = 0.00385$

TRIM R9 FOR $V_{OUT} = 0$ @ 0°C
 TRIM R12 FOR $V_{OUT} = 10\text{V}$ @ 100°C
 TRIM R14 FOR $V_{OUT} = 5\text{V}$ @ 50°C

USE TRIM SEQUENCE AS SHOWN. TRIMS ARE NON-INTERACTIVE SO THAT ONLY ONE TRIM SEQUENCE IS NORMALLY REQUIRED.

*FEEDBACK LINEARIZES OUTPUT TO $\pm 0.005^\circ\text{C}$ FROM -50°C TO $+150^\circ\text{C}$

**WIREWOUND RESISTORS WITH LOW TC

2-Pole Low Pass Filtered Reference

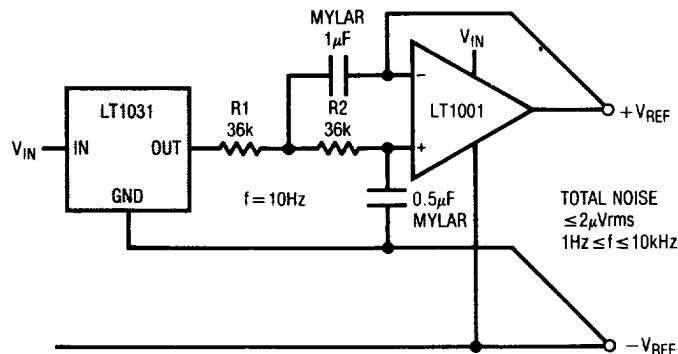

TOTAL NOISE $\leq 2\mu\text{Vrms}$
 $1\text{Hz} \leq f \leq 10\text{kHz}$

APPLICATION CIRCUITS

Negative Shunt Reference Driven by Current Source

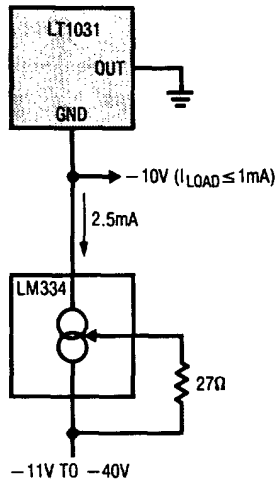

3

Precision DAC Reference with System TC Trim

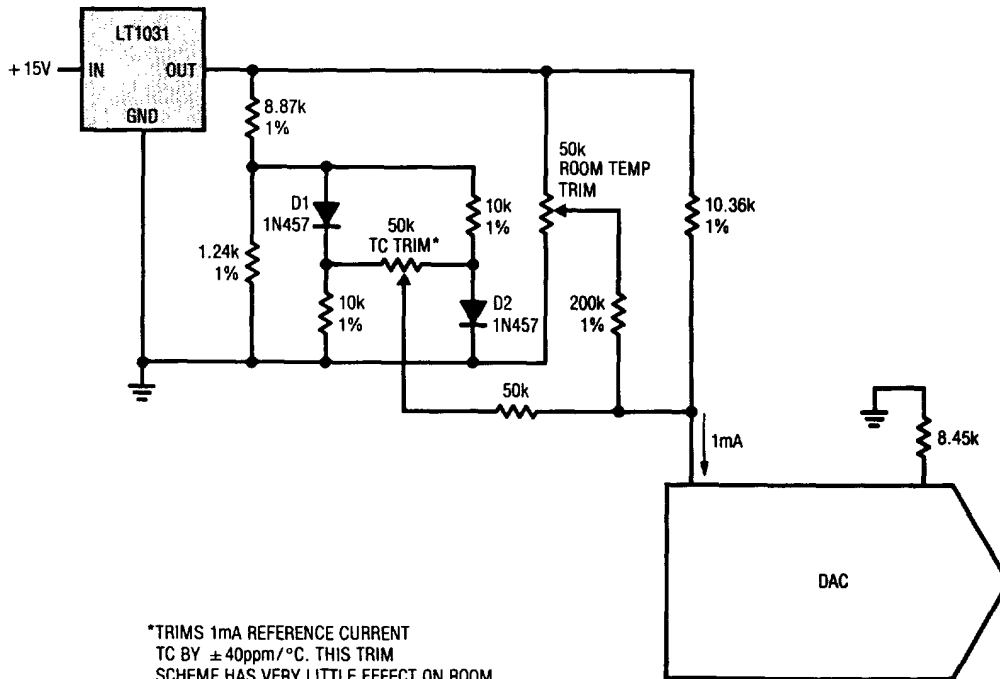

*TRIMS 1mA REFERENCE CURRENT TC BY $\pm 40\text{ppm}/^\circ\text{C}$. THIS TRIM SCHEME HAS VERY LITTLE EFFECT ON ROOM TEMPERATURE CURRENT TO MINIMIZE ITERATIVE TRIMMING.

EQUIVALENT SCHEMATIC

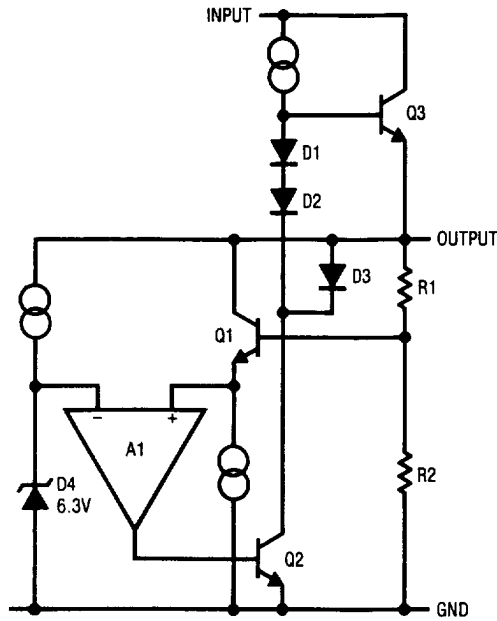

PACKAGE DESCRIPTION

T0-5

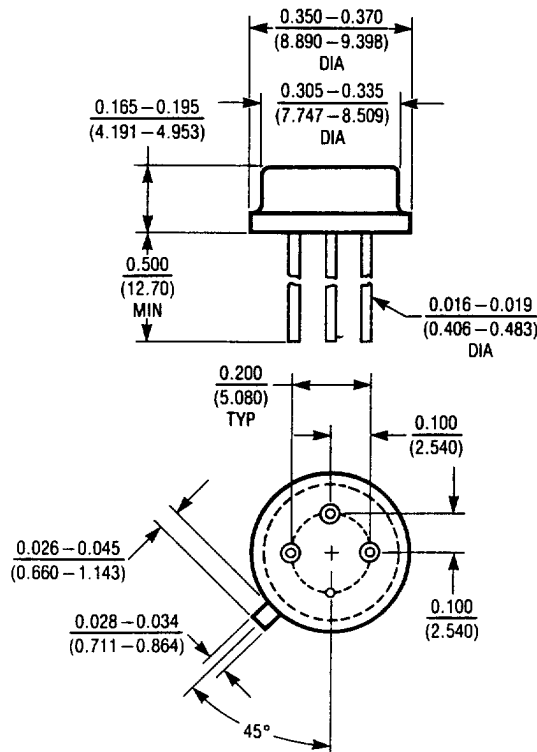

	T_{jmax}	θ_{jA}	θ_{jC}
LH0070	150°C	150°C/W	45°C/W
LT1031M	150°C	150°C/W	45°C/W
LT1031C	85°C	150°C/W	45°C/W