

ICM7206 CMOS Touch Tone™ Encoder

FEATURES

- Low cost system with minimum component count
- Fully integrated oscillator uses 3.58 MHz color TV crystal
- High current bipolar output driver
- Low output harmonic distortion
- Wide operating supply voltage range: 3 to 6 volts
- Uses inexpensive single contact per key calculator type keyboard (ICM7206/C/D)
- Extremely low power $\leq 5.5\text{mW}$ with a 5.5V supply
- Single and dual tone capabilities
- Multiple key lockout
- Disable output: provides output switch function whenever a key is pressed
- Custom options available

GENERAL DESCRIPTION

The Intersil ICM7206/A/B/C/D are 2-of-8 sine wave tone encoders for use in telephone dialing systems. Each circuit contains a high frequency oscillator, two separate programmable dividers, a D/A converter, and a high level output driver.

The reference frequency is generated from a fully integrated oscillator requiring only a 3.58 MHz color TV crystal. This frequency is divided by 8 and is then gated into two divide by N counters (possible division ratios 1 through 128) which provide the correct division ratios for the upper and lower band of frequencies. The outputs from these two divide by N counters are further divided by 8 to provide the time sequencing for a 4 voltage level synthesis of each sinewave. Both sinewaves are added and buffered to a high current output driver, with provisions made for up to two external capacitors for low pass filtering, if desired. Typically, the total output harmonic distortion is 20% with no L.P. filtering and it may be reduced to typically less than 5% with filtering. The output drive level of the tone pairs will be approximately

-3dBV into a 900 ohm termination. The skew between the high and low groups is typically 2.5 dB without low pass filtering.

The 7206 uses either a 3 x 4 or 4 x 4 single contact keyboard; the oscillator will run whenever the power is applied, and the DISABLE output consists of a p-channel open drain FET whose source is connected to V^+ .

The 7206A can also use a 3 x 4 or 4 x 4 keyboard, but requires a double contact type with the common line tied to V^+ . The oscillator will be on whenever power is applied; the DISABLE output consists of a p-channel open drain FET; its' source is connected to V^+ .

The 7206B requires a 4 x 4 double contact keyboard with the common line tied to V^- . The oscillator will be on only during the time that a ROW is enabled, and the DISABLE output consists of an n-channel open drain FET with its' source tied to V^- .

The 7206C uses either a 3 x 4 or 4 x 4 single contact keyboard; the oscillator will be on only during the time that a key is depressed. The DISABLE output consists of an n-channel open drain FET with its source tied to V^- .

The 7206D uses a single contact 3 x 4 or 4 x 4 keyboard. The oscillator will be on only during the time that a key is depressed. DISABLE output consists of a p-channel open drain FET with its source tied to V^+ .

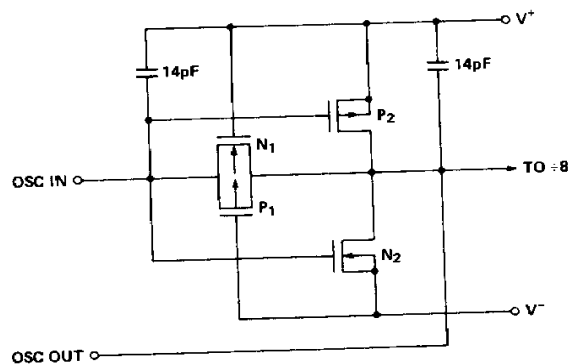

ICM7206 Oscillator

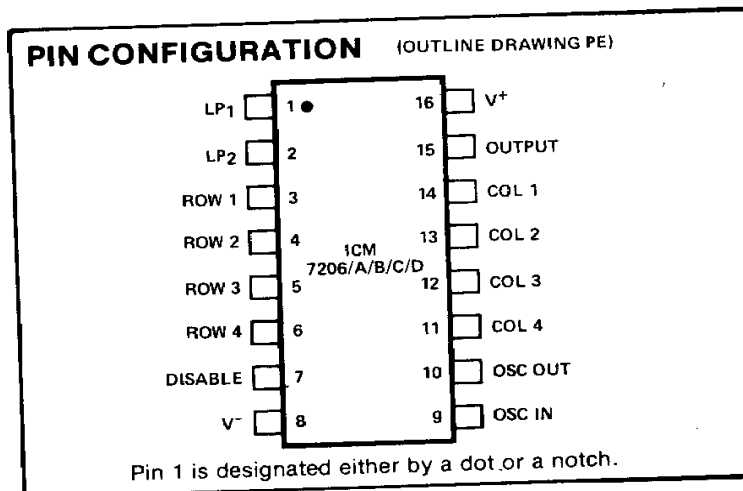

ORDERING INFORMATION

PART NUMBER	TEMPERATURE RANGE	PACKAGE
ICM7206 JPE	-40° C to +85° C	Plastic
ICM7206A JPE	-40° C to +85° C	Plastic
ICM7206B JPE	-40° C to +85° C	Plastic
ICM7206C JPE	-40° C to +85° C	Plastic
ICM7206D JPE	-40° C to +85° C	Plastic
ICM7206/D	-40° C to +85° C	DICE
ICM7206A/D	-40° C to +85° C	DICE
ICM7206B/D	-40° C to +85° C	DICE
ICM7206C/D	-40° C to +85° C	DICE
ICM7206D/D	-40° C to +85° C	DICE

ICM7206 Family



ABSOLUTE MAXIMUM RATINGS (Note 1)

Supply Voltage (Note 2)	6.0V
Supply Current V^- (terminal 8)	25mA
Supply Current V^+ (terminal 16)	40mA
Disable Output Volt. (term. 7)	Not more pos. than V^+ nor more neg. than $-6V$ with respect to V^+

Output Volt. (term. 15)	Not more pos. than +5V with respect to V^- nor more neg. than -1.0 with respect to V^-
Output Current (terminal 15)	25mA
Power Dissipation	300mW
Operating Temperature Range	-40°C to $+85^\circ\text{C}$
Storage Temperature Range	-55°C to $+125^\circ\text{C}$

- NOTE 1.** Stresses above those listed under Absolute Maximum Ratings may cause permanent damage to the device. These are stress ratings only and functional operation of the device at these or any other conditions above those indicated in the operational sections of the specifications is not implied. Exposure to absolute maximum rating conditions for extended periods may affect device reliability.
- NOTE 2.** The ICM7206 family has a zener diode connected between V^+ and V^- having a breakdown voltage between 6.2 and 7.0 volts. If the currents into terminals 8 and 16 are limited to 25 and 40mA maximum respectively, the supply voltage may be increased above 6 volts to zener voltage. With no such current limiting, the supply voltage must not exceed 6 volts.

TYPICAL OPERATING CHARACTERISTICS

TEST CONDITIONS: $V^+ = 5.5V$, Test Circuit, $T_A = 25^\circ\text{C}$ unless otherwise specified.

PARAMETER	SYMBOL	CONDITIONS	MIN.	TYP.	MAX.	UNITS	
Supply Current	I^+	R_L disconnected		450	1000	μA	
Guaranteed Operating Supply Voltage Range (Note 3)	V_{OP}	$-40^\circ\text{C} \leq T_A \leq +85^\circ\text{C}$	3.0		6.0	V	
Peak to Peak Output Voltage	V_{OUT}	C_1, C_2 disconnected — Low Band	0.90	1.15	1.45	V	
RMS Output Voltage		$R_L = 1k\Omega$, no filtering — High Band	1.10	1.40	1.70		
		$R_L = 1k\Omega$, $f_{OUT} = 697\text{Hz}$	C_2 Only		480		
			C_1 to C_2		480		
		No filtering		490			
		$R_L = 1k\Omega$, $f_{OUT} = 1633\text{Hz}$	C_1		490		
	C_1 to C_2			580			
	No filtering			655			
Skew Between High and Low Band Output Voltages		$R_L = 1k\Omega$, C_1, C_2 disconnected		2.5	3.0	dB	
Output Impedance	Z_O	$R_L = 1k\Omega$		90	200	Ω	
Total Output Harmonic Distortion	THD1	Either Hi or Low Bands No Low Pass Filtering		25		K Ω	
Total Output Harmonic Distortion	THD2	$R_L = 1k\Omega$, $C_1 = .002\mu\text{F}$, $f_{OUT} = 697\text{Hz}$ $C_2 = 0.02\mu\text{F}$, $f_{OUT} = 1633\text{Hz}$		20	25	%	
Maximum Output Voltage Level	V_{OH}	$R_L = 1k\Omega$		2.3	10		
Minimum Output Voltage Level	V_{OL}	$R_L = 1k\Omega$		1.0	10	V	
Keyboard Input Pullup Resistors	R_{IN}	Terminals 3,4,5,6,11,12,13,14	0.5				
Keyboard Input Capacitance	C_{IN}	Terminals 3,4,5,6,11,12,13,14	35	100	150	K Ω	
Guaranteed Oscillator Frequency Range (Note 4)	f_{OSC}	$3 \leq (V^+ - V^-) \leq 6V$			5	pF	
Guaranteed Oscillator Frequency Range		$4V \leq (V^+ - V^-) \leq 6V$	2.0		4.5		
System Startup Time on Application of Power	t_{ON}	ICM7206, ICM7206A		10		ms	
System Startup Time on Application of Power and Key Depressed Simultaneously		ICM7206B, ICM7206C, ICM7206D			7		
DISABLE Output Saturation Resistance (ON STATE)	R_D	See Logic Table for Input Conditions Current = 4mA		330	700	Ω	
DISABLE Output Leakage (OFF STATE)	I_{OLK}	See Logic Table for Input Conditions			10	μA	
Oscillator Load Capacitance	C_{OSC}	Measured between terminals 9 & 10, no supply voltage applied to circuit $-40^\circ\text{C} \leq T_A \leq 85^\circ\text{C}$		7		pF	
Guaranteed Output Frequency Tolerance	f_O	Any output frequency Crystal tolerance $\pm 60\text{ppm}$ Crystal load capacitance $C_L = 30\text{pF}$			± 0.75	%	
Oscillator Startup Time ICM7206B, C, D	t_{START}	$V^+ = 3V$ (Note 5)			7	ms	

- NOTE 3:** Operation above 6 volts must employ supply current limiting. Refer to 'ABSOLUTE MAXIMUM RATINGS' and the Application Notes for further information.
- NOTE 4:** The ICM7206 family uses dynamic high frequency circuitry in the initial 2³ divider resulting in low power dissipation and excellent performance over a restricted frequency range. Thus, for reliable operation with a 6 volt supply an oscillator frequency of not less than 2MHz must be used.
- NOTE 5:** After row input is enabled.

TRUTH TABLE

LINE	ROWS (1) ACTIVATED	COLS (2) ACTIVATED	OUTPUT (TERMINAL #15)	DISABLE (TERMINAL #7)	COMMENTS
1	0	0	Off	Off	Quiescent State
2	1	1	$f_{row} + f_{col}$	On	Dual Tone
3	1	2 or 3 (incl. col #4)	f_{row}	On	Single Tone
4	2 or 3	1	f_{col}	On	Single Tone
5	2 or 3	2 or 3 (excl. col #3)	D.C. Level	On	No Tone
6	1	4 or 3 (must excl. col #4)	f_{row} , 50% Duty Cycle	f_{row} , 50% Duty Cycle	f_{row} Test
7	4	1	f_{col} , 50% Duty Cycle	f_{col} , 50% Duty Cycle	f_{col} Test
8	0	1 or 2 or 3 or 4	Off	Off	n/a*
9	1	0	902Hz + f_{row}	On	n/a*
10	2 or 3	0	902Hz	On	n/a*
11	4	0	902Hz, 50% Duty Cycle	902Hz, 50% Duty Cycle	n/a*
12	2 or 3 or 4	4	D.C. Level	Indeterminate	Multiple Key Lockout
13	4	2 or 3 or 4	D.C. Level	Indeterminate	Multiple Key Lockout

*n/a — not applicable to telephone calling.

Note 1: Rows are activated for the ICM7206/C by connecting to a negative supply voltage with respect to V^+ (terminal 16) at least 33% of the value of the supply voltage ($V^+ - V^-$). For the ICM7206A rows (and columns) are activated by connecting to a positive supply voltage with respect to V^- (terminal 8) at least 33% of the value of the supply voltage ($V^+ - V^-$). The rows and columns of the ICM7206B are activated by connecting to a negative supply voltage.

Note 2: Columns (ICM7206) are activated by being connected to a positive supply voltage with respect to V^- (terminal 8) at least 33% of the value of the supply voltage ($V^+ - V^-$).

COMMENTS

All combinations of row and column activations are given in the truth table. Lines 1 thru 7 and 12, 13 represent conditions obtainable with a matrix keyboard. Lines 8 thru 11 are given only for completeness and are not pertinent to telephone dialing.

Lines 6 and 7 show conditions for generating 50% duty cycle full amplitude signals useful for rapid testing of the row and column frequencies on automatic test equipment. In all other cases, output frequencies on terminal 15 are single or dual 4 level synthesized sine waves.

A 'DC LEVEL' on terminal 15 may be any voltage level between approximately 1.2 and 4.3 volts with respect to V^- (terminal 8) for a 5.5 volt supply voltage.

The impedance of the OUTPUT (terminal 15) is approximately 20K ohms in the OFF state. The 'DISABLE OUT-OUT' ON and OFF conditions are defined in the TYPICAL OPERATING CHARACTERISTICS.

SCHEMATIC DIAGRAM

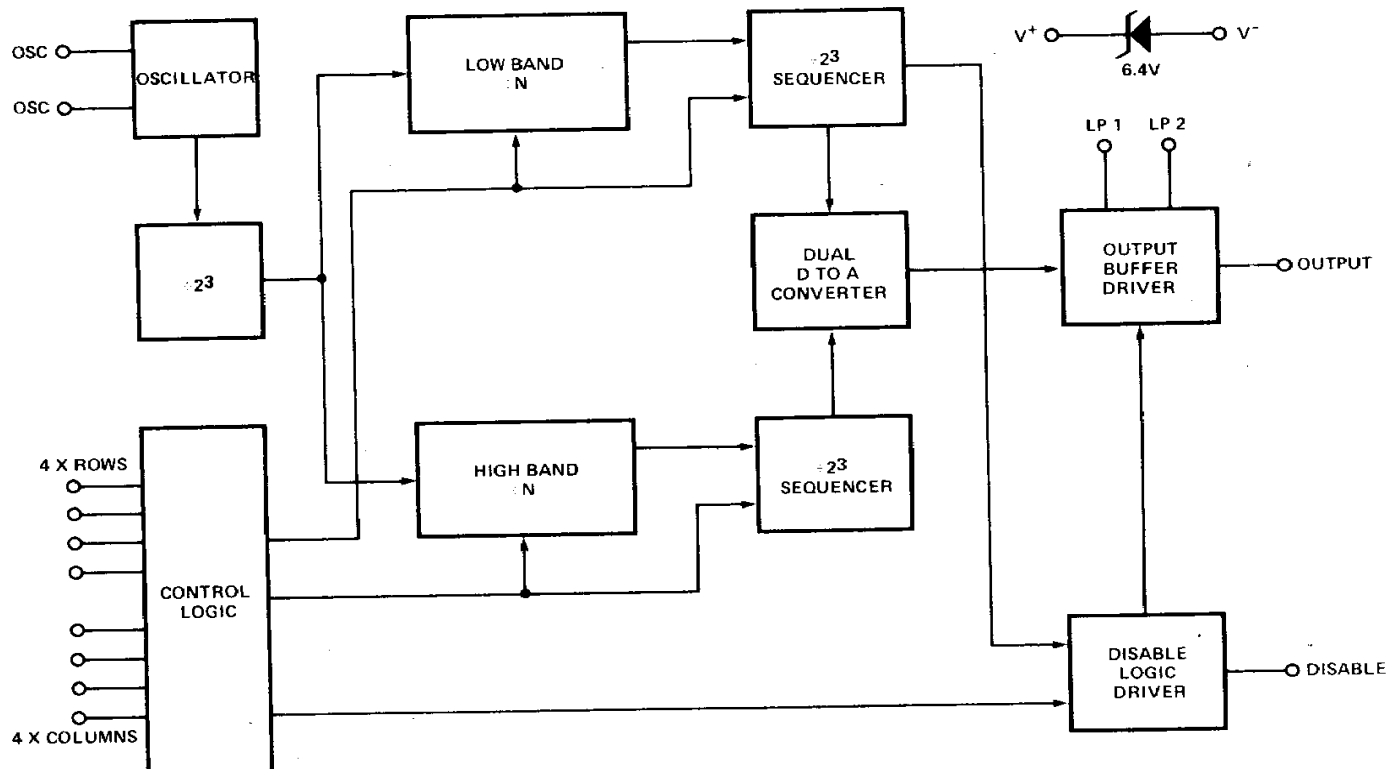

ICM7206 Family



TEST CIRCUIT (single contact keyboard devices shown)

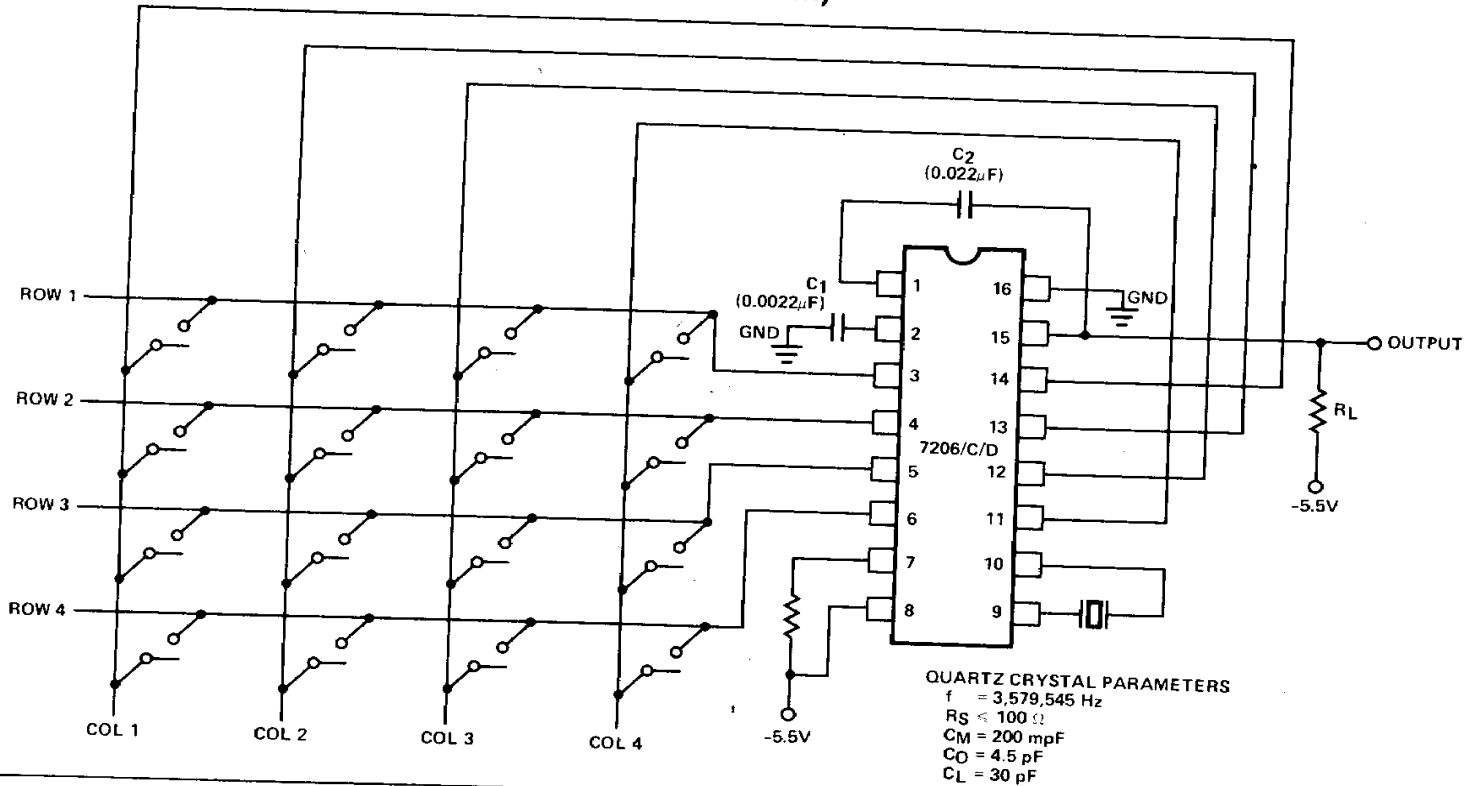

TYPICAL OPERATING CHARACTERISTICS

SUPPLY CURRENT AS A FUNCTION OF SUPPLY VOLTAGE

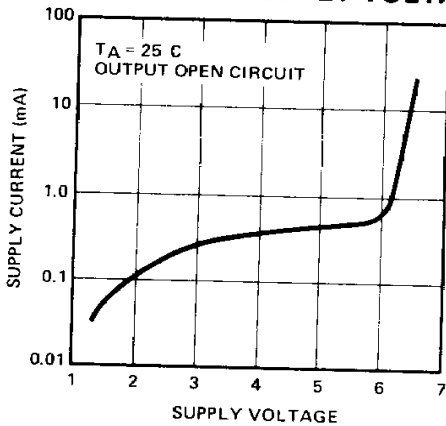

TOTAL HARMONIC DISTORTION AS A FUNCTION OF LOAD RESISTANCE

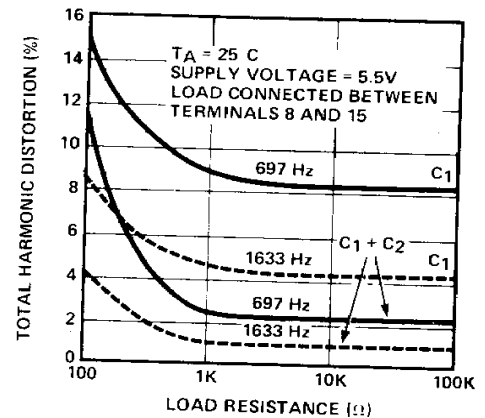

OSCILLATOR FREQUENCY DEVIATION AS A FUNCTION OF SUPPLY VOLTAGE

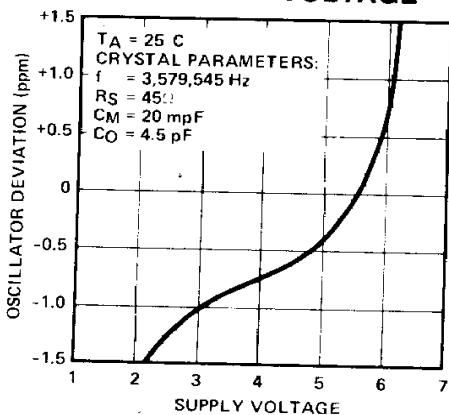

PEAK TO PEAK OUTPUT VOLTAGE AS A FUNCTION OF SUPPLY VOLTAGE

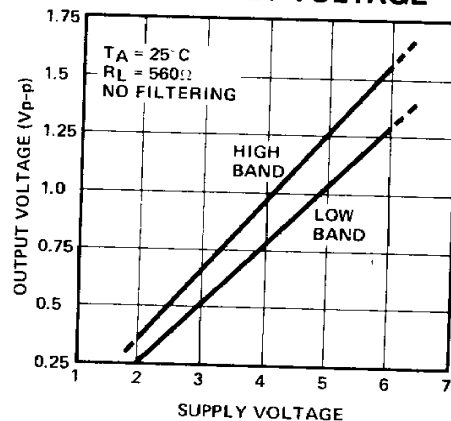

7

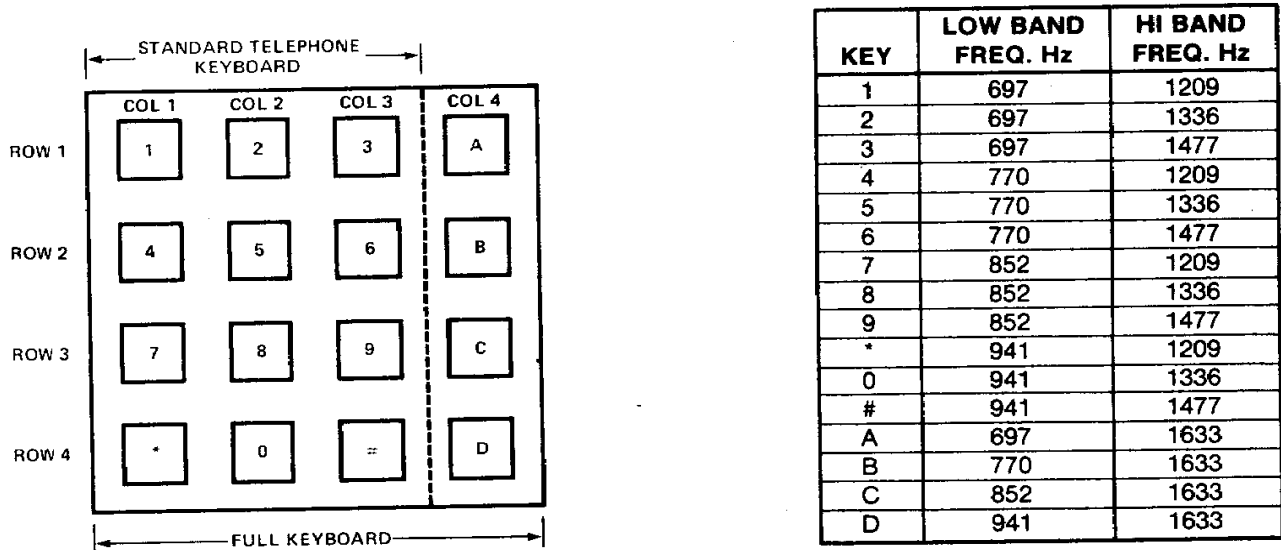

FIGURE 1: Keyboard Frequencies

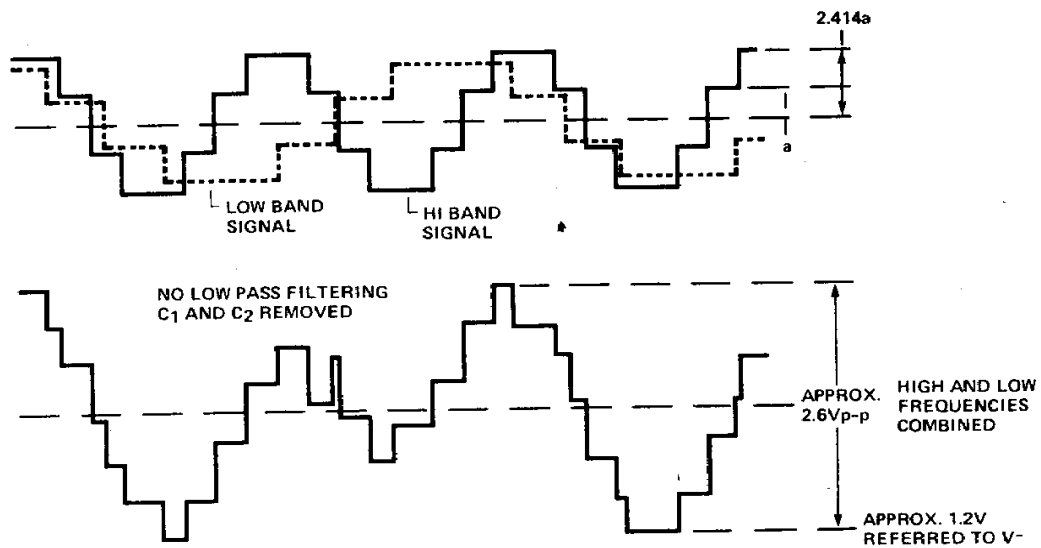

FIGURE 2

Figure 2 shows individual currents of a low band and high band frequency pair into the summing node A (see Figure 3) and the resultant voltage waveform.

DESIRED FREQUENCY Hz	ACTUAL FREQUENCY Hz	FREQUENCY DEVIATION %	DIVIDE BY N RATIO
697	699.13	+0.30	80
770	766.17	-0.50	73
852	847.43	-0.54	66
941	947.97	+0.74	59
1209	1215.88	+0.57	46
1336	1331.68	-0.32	42
1477	1471.85	-0.35	38
1633	1645.01	+0.74	34

APPLICATION NOTES

1. Device Description

The ICM7206 family is manufactured with a standard metal gate C-MOS technology having proven reliability and excellent reproducibility resulting in extremely high yields. The techniques used in the design have been developed over many years and are characterized by wide operating supply voltage ranges and low power dissipation.

To minimize chip size, all diffusions used to define source-drain regions and field regions are butted up together. This results in approximately 6.3 volt zener breakdown between the supply terminals, and between all components on chip. As a consequence, the usual C-MOS static charge problems and handling problems are not experienced with the ICM7206.

The oscillator consists of a medium size C-MOS inverter having on chip a feedback resistor and two capacitors of 14pF each, one at the oscillator input and the other at the oscillator output. The oscillator is followed by a dynamic $\div 2^3$ circuit which divides the oscillator frequency to 447,443Hz. This is applied to two programmable dividers each capable of division ratios of any integer between 1 and 128, and each counter is controlled by a ROM. The outputs from the programmable counters drive sequencers (divide by 8) which generate the eight time slots necessary to synthesize the 4-level sine waves.

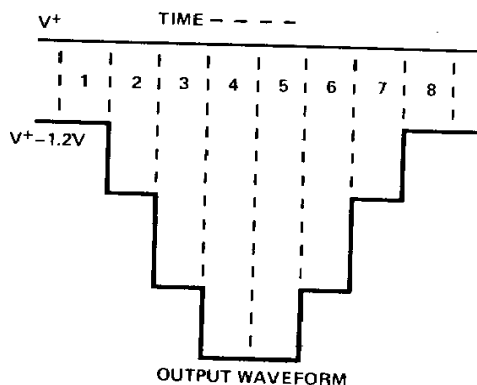
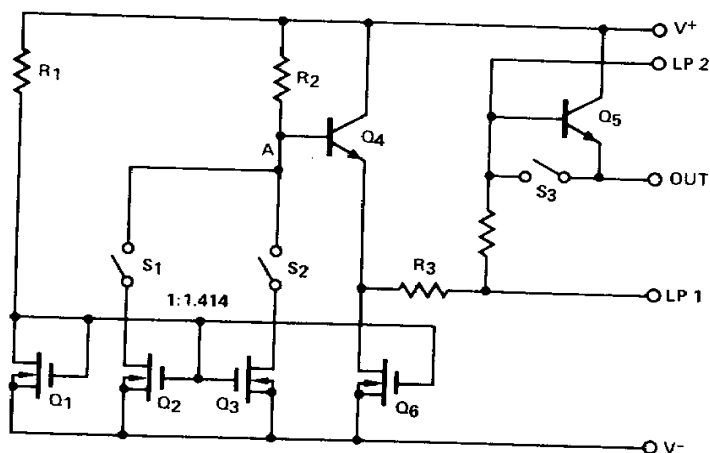

FIGURE 3: D to A Converter and Output Buffer

The control logic block recognizes signals on the row and column inputs that are only a small fraction of the supply voltage, thereby permitting the use of a simple matrix single contact per key keyboard, rather than the more usual two contacts per key type having a common line. The row and column pullup resistors are equal in value and connected to the opposite supply terminals (ICM7206/C only; for the ICM7206A all pullup resistors are connected to the V^- terminal and for the ICM7206B they are tied to the V^+). Therefore, connecting a row input to a column input generates a voltage on those inputs which is one half of the supply voltage.

The ICM7206 family employs a unique but extremely simple digital to analog (D to A) converter. This D to A converter produces a 4 level synthesized sine wave having an intrinsic total harmonic distortion level of approximately 20%. Figure 3 shows a single channel D to A converter. The current sources Q_2 and Q_3 are proportioned in the ratio of 1:1.414. During time slots 1 and 8 both S_1 and S_2 are off, during time slots 2 and 7 only S_1 is on, during time slots 3 and 6 only S_2 is on, and during time slots 4 and 5 both S_1 and S_2 are on. The resultant currents are summed at node A, buffered by Q_4 and further buffered by R_3 , R_4 and Q_5 . Switch S_3 allows the output to go into a high impedance mode under quiescent conditions.

Node A is the common summing point for both the high and low band frequencies although this is not shown in Figure 3.

The synthesized sine wave has negligible even harmonic distortion and very low values of third and fifth harmonic distortion thereby minimizing the filtering problems necessary to reduce the total harmonic distortion to well below the 10% level required for touch tone telephone encoding. Figure 4 shows the low pass filter characteristic of the output buffer for $C_1 = 0.0022\mu F$ and $C_2 = 0.022\mu F$. A small peak of 0.4dB occurs at 1100Hz with sharp attenuation (12dB per octave) above 2500Hz. This type of active filter produces a sharper and more desirable knee characteristic than would two simple cascaded RC networks.

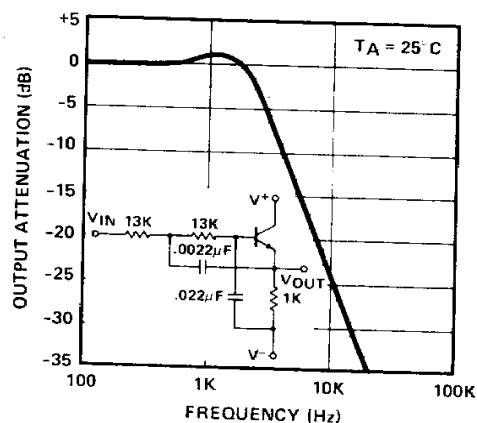

FIGURE 4: Frequency Attenuation Characteristics of the Output Buffer

2. Latchup Considerations

Most junction isolated C-MOS integrated circuits, especially those of moderate or high complexity, exhibit latchup phenomena whereby they can be triggered into an uncontrollable low impedance mode between the supply terminals. This can be due to gross forward biasing of inputs or outputs (with respect to the supply terminals), high voltage supply transients, or more rarely by exceptional fast rate of rise of supply voltages.

The ICM7206 family is no exception, and precautions must be taken to limit the supply current to those values shown in the ABSOLUTE MAXIMUM RATINGS. For an example, do not use a 6 volt very low impedance supply source in an **electrically extremely noisy** environment unless a 500 ohm current limiting resistor is included in series with the V^- terminal. For normal telephone encoding applications no problems are envisioned, even with low impedance transients of 100 volts or more, if circuitry similar to that shown in the next section is used.

3. Typical Application (Telephone Handset)

A typical encoder for telephone handsets is shown in Figure 5. This encoder uses a single contact per key keyboard and provides all other switching functions electronically. The diode connected between terminals 8 and 15 prevents the

output going more than 1 volt negative with respect to the negative supply V^- and the circuit operates over the supply voltage range from 3.5 volts to 15 volts on the device side of the bridge rectifier. Transients as high as 100 volts will not cause system failure, although the encoder will not operate correctly under these conditions. Correct operation will resume immediately after the transient is removed.

The output voltage of the synthesized sine wave is almost directly proportional to the supply voltage ($V^+ - V^-$) and will increase with increase of supply voltage until zener breakdown occurs (approximately 6.3 volts between terminals 8 and 16) after which the output voltage remains constant.

4. Portable Tone Generator

The ICM7206A/B require a two contact key keyboard with the common line connected to the positive supply (neg for ICM7206B) (terminal 16). A simple diode matrix may be used with this keyboard to provide power to the system whenever a key is depressed, thus avoiding the need for an on/off switch. In Figure 6 the tone generator is shown using a 9 volt battery. However, if instead, a 6 volt battery is used, the diode D_4 is not required. It is recommended that a 470 ohm resistor still be included in series with a negative (positive) supply to prevent accidental triggering of latchup.

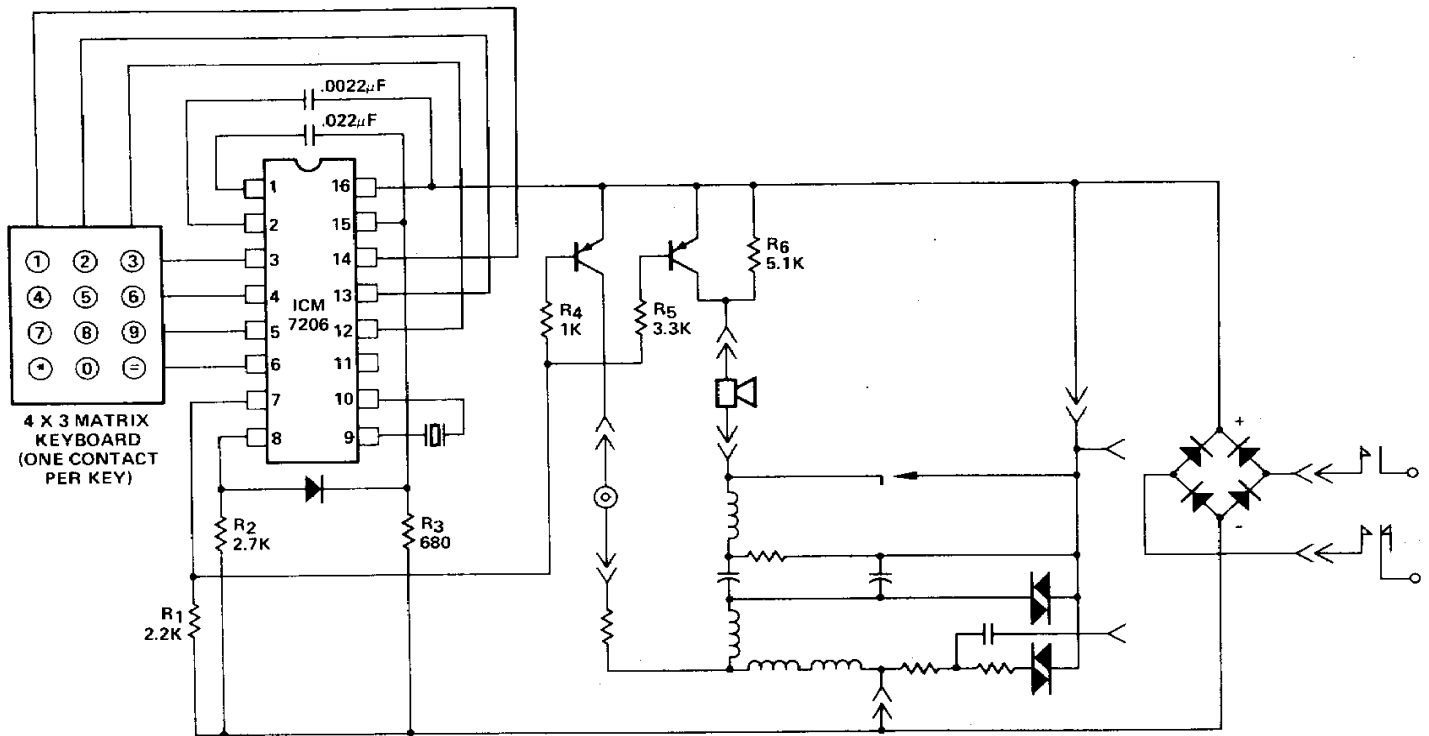

NOTE: If dual contact keyboard is used, common should be left floating.

FIGURE 5: Telephone Handset Touch Tone Encoder

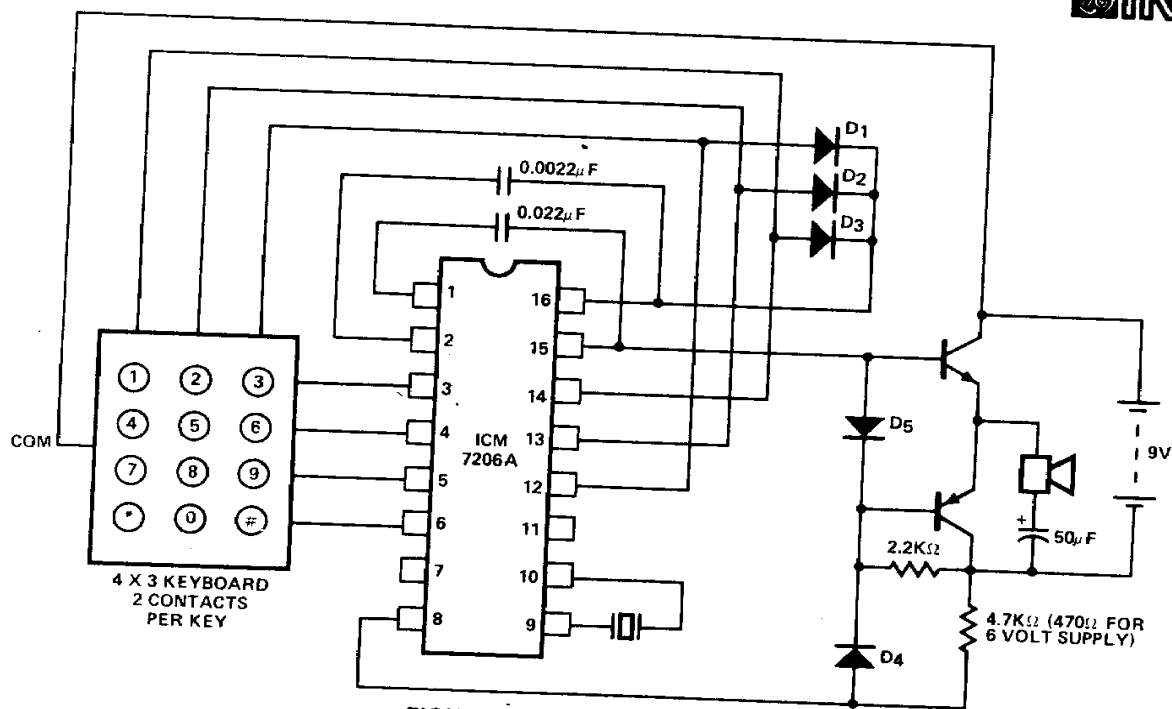

FIGURE 6: Portable Tone Generator

OPTIONS

(For additional information consult the factory)

Options can be achieved using metal mask additions to provide the following.

- 1) The sequence or position of either the row or column terminals can be interchanged i.e., row 1 terminal 3 could become terminal 11, etc.
- 2) Any frequency oscillator from approximately 0.5MHz to 7MHz can be chosen. Note that the accuracy of the output frequencies will depend on the exact oscillator frequency.

For instance, a 1 MHz crystal could be used with worst case output frequency error of 0.8%. Or, if high accuracy is required, $\pm 0.25\%$, oscillator frequencies of 5,117,376Hz or 2,558,688Hz could be selected. ROM's are used to program the dividers.

- 3) The 'DISABLE' output may be changed to an inverter or an uncommitted drain n-channel transistor.
- 4) The oscillator may be disabled until a key is depressed.

7

CHIP TOPOGRAPHY

Chip Dimensions
0.60" (1.524mm) x 0.101"
(2.565mm)

Chip may be die attached using conventional eutectic or epoxy procedures. Wire bonding may be either aluminum ultrasonic or gold compression.

