

RoHS COMPLIANT

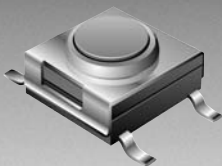

BOURNS®

Features

- Through-hole and SMD styles available
- Available sharp click feel with a positive tactile feedback
- Ultra-miniature and lightweight structure suitable for high density mounting
- Designed for washing after soldering
- RoHS compliant*



The ST(H,M,J,R)W Series is currently available, although not recommended for new designs.

- Insert molding in the contact with special treatment prevents flux buildup during soldering and permits autodipping

ST(H,M,J,R)W Series Sealed Tact Switch

Electrical Characteristics

Electrical Life.....100,000 cycles min.
 RatingDC 12 V, 50 mA
 Contact Resistance.....100 mohms max.
 Insulation Resistance ..100 Mohms min.
 DC 500 V min.

Dielectric Strength

.....AC 250 V for 1 minute
 Contact Arrangement...1 pole 1 position

Environmental Characteristics

Mechanical Life.....100,000 cycles min.
 Operation Force160 g, 260 g
 Tolerance±50 g
 Stop Strength..Place the switch vertical, a static load of 3 kg shall be applied in the direction of actuator operation for a period of 15 seconds
 Stroke.....0.25 mm (+0.2 mm, -0.1 mm)
 Operating Temperature Range-25 °C to +70 °C
 Storage Temperature Range-30 °C to +80 °C
 Vibration TestMIL-STD-202F, Method 201A
 Frequency10-55-10 Hz/1 minute
 DirectionsX,Y,Z 3 mutually perpendicular directions
 Time.....2 hours each direction, high reliability
 Shock TestMIL-STD-202F, Method 213B, Condition A
 Gravity50 g (peak value), 11 msec.
 Directions/Time.....6 sides and 3 times in each direction

Physical Characteristics

Cover Materials.....Stainless steel
 Base Materials.....Thermoplastic LCP
 UL94V-0 black
 Actuator Materials.....Thermoplastic
 Nylon UL94V-0 (680, 690)
 Color.....Brown (Silver 680 type)
 Contact Disc. MaterialsPhosphor bronze with gold cladding
 Terminal MaterialsBrass with silver cladding

Product Dimensions

STHW

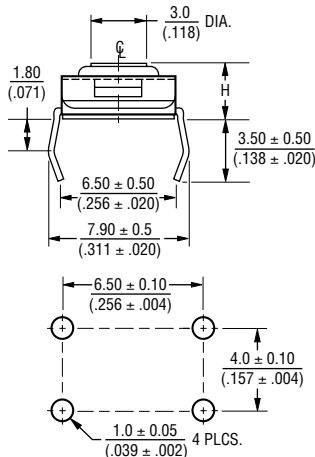
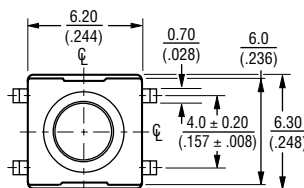

STJW

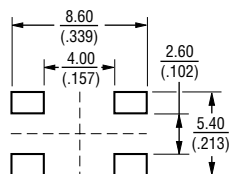
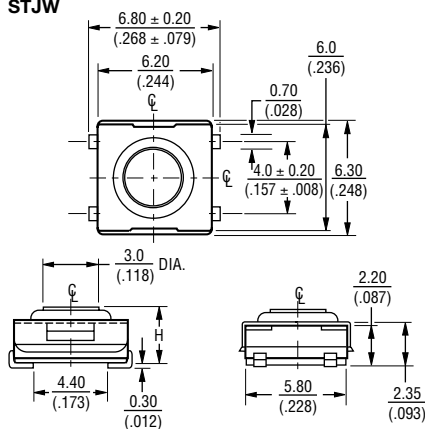

STMW

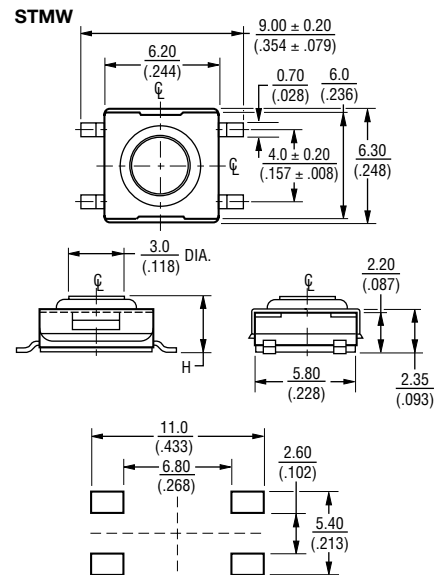

STRW

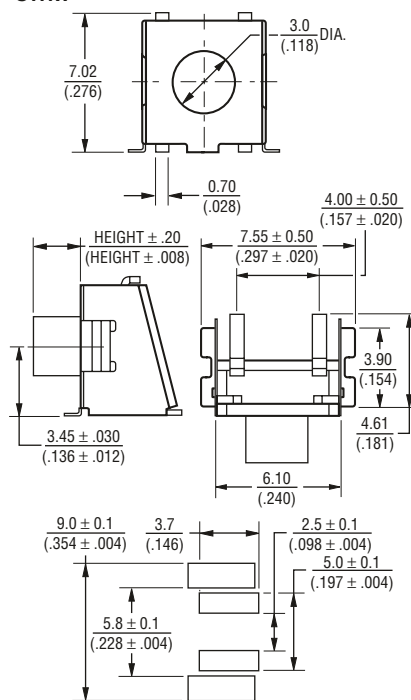

DIMENSIONS: MM
(IN)

CIRCUIT DIAGRAM

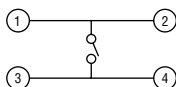

*RoHS Directive 2002/95/EC Jan 27 2003 including Annex. Specifications are subject to change without notice. Customers should verify actual device performance in their specific applications.

ST(H,M,J,R)W Series Sealed Tact Switch

BOURNS®

Packaging Specifications

STJW
STMW

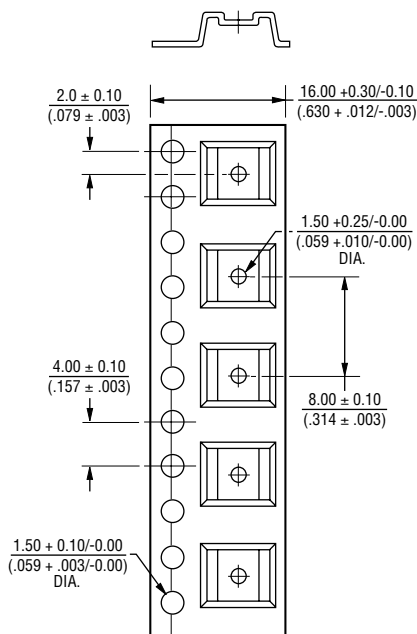

STMW
STJW
STHW

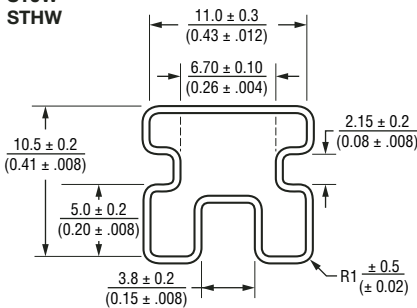

STRW

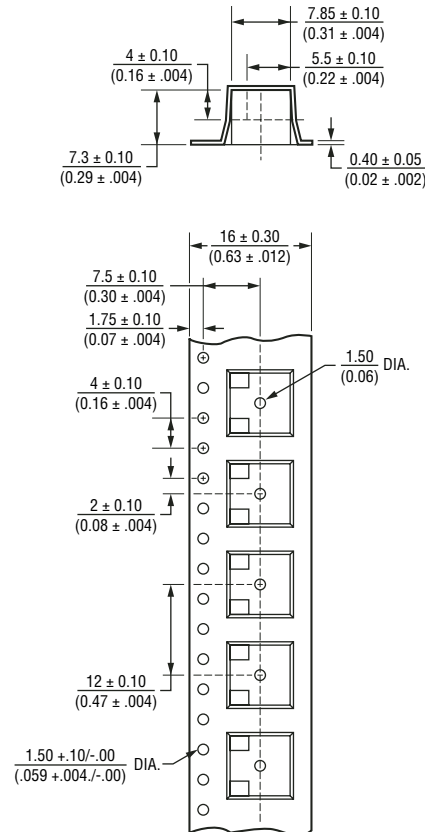

DIMENSIONS: $\frac{\text{MM}}{\text{(INCHES)}}$

How to Order

STM W - 6 60 - N TR

Model _____
 STM = SMD "G" style
 STH = Through-hole
 STJ = SMD "J" style
 STR = SMD right angle

Product Type _____
 W = Washable

Size _____
 6 = 6 mm

Height (STM, STH, STJ) _____
 50 = $\frac{3.5}{(0.14)}$ (N, R, V)
 60 = $\frac{3.1}{(0.12)}$ (N)
 67 = $\frac{5.2}{(0.20)}$ (N, R, V)
 80 = $\frac{2.3}{(0.09)}$ (S)
 90 = $\frac{3.8}{(0.15)}$ (N, R, V)

Height (STR) _____
 10 = $\frac{0}{(0.00)}$ (N, R)
 20 = $\frac{0.8}{(0.03)}$ (N, R)
 30 = $\frac{1.0}{(0.04)}$ (N, R)
 40 = $\frac{2.3}{(0.09)}$ (N, R)

Actuating Force _____
 S = 160 g (Silver head)
 N = 160 g (Brown head)
 R = 260 g (Red head)
 V = 360 g (Clear head)

Packaging Option _____
 TR = Embossed tape (STM, STJ, STR only)
 610/620/630/640 = 700 pcs.
 650 = 1900 pcs.
 660 = 2000 pcs.
 667 = 900 pcs.
 680 = 2000 pcs.
 690 = 1900 pcs.
 ___ = 75 pcs./tube (STM, STJ, STH only)

Reflow Soldering Profile

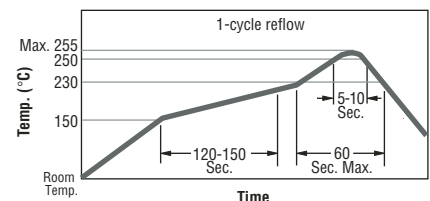

REV. 02/06

Specifications are subject to change without notice.
 Customers should verify actual device performance in their specific applications.