

Single Schmitt trigger

BU4S584

The BU4S584 is an ultra-compact IC with one circuit of the inverter-type Schmitt trigger, BU4584B, built into an SMP package.

●Features

- 1) Low current dissipation.
- 2) Super-mini mold package designed for surface mounting.
- 3) Wide range of operating power supply voltage.
- 4) Direct drive of 2 L-TTL inputs and 1 LS-TTL input.

●Block diagram

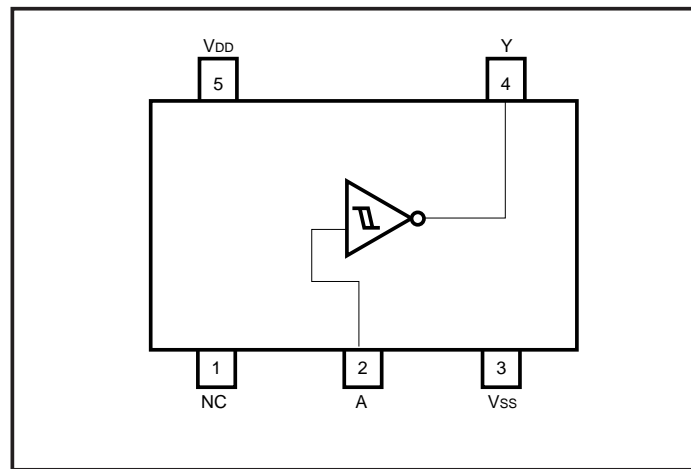

●Absolute maximum ratings (Ta = 25°C)

Parameter	Symbol	Limits	Unit
Power supply voltage	V _{DD}	V _{SS} - 0.3 ~ V _{SS} + 18	V
Power dissipation	P _d	170	mW
Input current	I _{IN}	± 10	mA
Operating temperature	T _{opr}	- 40 ~ + 85	°C
Storage temperature	T _{stg}	- 55 ~ + 150	°C
Input voltage	V _{IN}	V _{SS} - 0.3 ~ V _{DD} + 0.3	V

Note 1: These values indicate the range limits of the voltage that can be applied to each pin without destroying it. Operation is not guaranteed at these values.

Note 2: Power dissipation is reduced by 1.7mW for each increase in Ta of 1°C over 25°C.

●Recommended operating conditions (Ta = 25°C, V_{SS} = 0V)

Parameter	Symbol	Min.	Typ.	Max.	Unit
Power supply voltage	V _{DD}	3	—	16	V
Input voltage	V _{IN}	0	—	V _{DD}	V

●Electrical characteristics

DC characteristics (unless otherwise noted, $V_{SS} = 0V$, $T_a = 25^\circ C$)

Parameter	Symbol	Min.	Typ.	Max.	Unit	V_{DD} (V)	Conditions	Measurement circuit
Input high level voltage	V_{IH}	3.5	—	—	V	5	—	Fig.1
		7.0	—	—	V	10		
		11.0	—	—	V	15		
Input low level voltage	V_{IL}	—	—	1.5	V	5	—	
		—	—	3.0	V	10		
		—	—	4.0	V	15		
Input high level current	I_{IH}	—	—	0.3	μA	18	$V_{IH} = 15V$	
Input low level current	I_{IL}	—	—	-0.3	μA	18	$V_{IL} = 0V$	
Output high level voltage	V_{OH}	4.95	—	—	V	5	$ I_{OUT} < 1\mu A$ $V_{IN} = V_{SS}$	
		9.95	—	—	V	10		
		14.95	—	—	V	15		
Output low level voltage	V_{OL}	—	—	0.05	V	5	$ I_{OUT} < 1\mu A$ $V_{IN} = V_{DD}$	
		—	—	0.05	V	10		
		—	—	0.05	V	15		
Output high level current	I_{OH}	-0.51	—	—	mA	5	$V_{OH} = 4.6V$	
		-2.1	—	—	mA	5	$V_{OH} = 2.5V$	
		-1.3	—	—	mA	10	$V_{OH} = 9.5V$	
		-3.4	—	—	mA	15	$V_{OH} = 13.5V$ $V_{IN} = V_{SS}$	
Output low level current	I_{OL}	0.51	—	—	mA	5	$V_{OL} = 0.4V$	
		1.3	—	—	mA	10	$V_{OL} = 0.5V$	
		3.4	—	—	mA	15	$V_{OL} = 1.5V$ $V_{IN} = V_{DD}$	
Hysteresis voltage	V_H	0.15	—	0.6	V	5	—	
		0.25	—	1.0	V	10		
		0.40	—	1.5	V	15		
Static current dissipation	I_{DD}	—	—	0.25	μA	5	$V_{IN} = V_{SS}, V_{DD}$	
		—	—	0.5	μA	10		
		—	—	1.0	μA	15		

Switching characteristics (unless otherwise noted, $V_{SS} = 0V$, $T_a = 25^\circ C$, $C_L = 50pF$)

Parameter	Symbol	Min.	Typ.	Max.	Unit	V_{DD} (V)	Conditions	Measurement circuit
						5		
Output rise time	t_{TLH}	—	70	—	ns	5	—	Fig.2
		—	35	—	ns	10		
		—	30	—	ns	15		
Output fall time	t_{THL}	—	70	—	ns	5	—	
		—	35	—	ns	10		
		—	30	—	ns	15		
Propagation delay time, "L" to "H"	t_{PLH}	—	125	—	ns	5	—	
		—	60	—	ns	10		
		—	50	—	ns	15		
Propagation delay time, "H" to "L"	t_{PHL}	—	125	—	ns	5	—	
		—	60	—	ns	10		
		—	50	—	ns	15		

● Measurement circuits

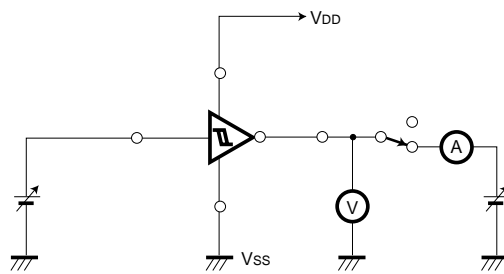

Fig.1 DC characteristics measurement circuit

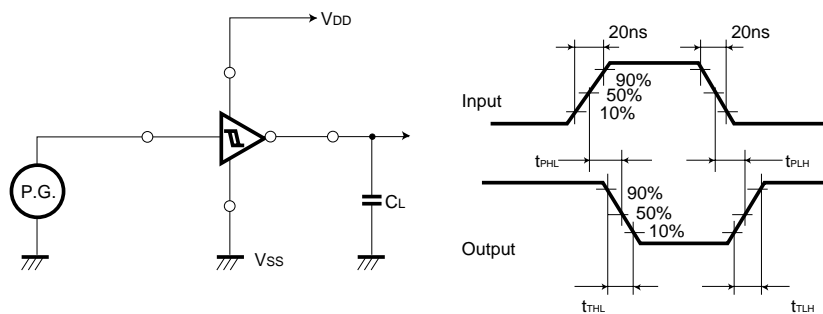

Fig.2 Switching characteristics measurement circuit

●External dimensions (Units: mm)

