

# Hex Schmitt trigger

## BU4584B / BU4584BF / BU4584BFV

The BU4584B, BU4584BF, and BU4584BFV are inverter-type Schmitt trigger circuits, with six circuits mounted on a single chip. These are ideal when enhanced noise immunity is required, and when wave form rectification circuits with slow rise or fall input times are involved.

### ●Features

- 1) Low power dissipation.
- 2) Wide range of operating power supply voltage.
- 3) High input impedance.
- 4) High fan-out.
- 5) Direct drive of 2 L-TTL inputs and LS-TTL input.

### ●Block diagram

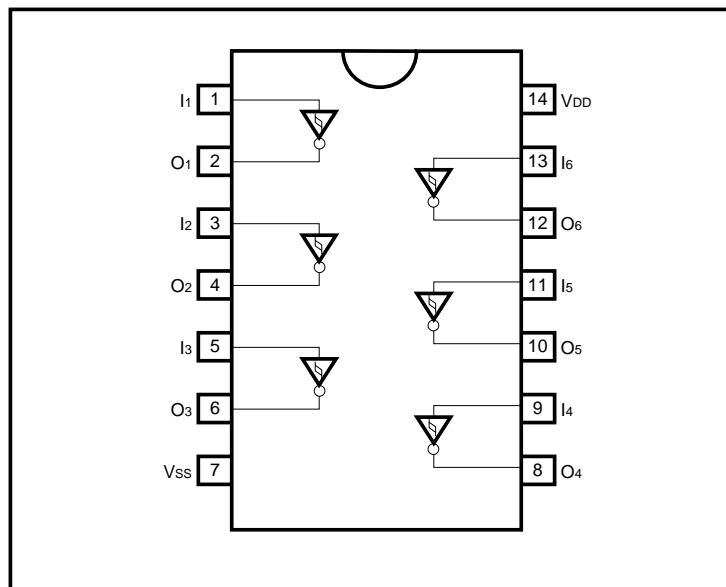

### ●Absolute maximum ratings ( $V_{SS} = 0V$ , $T_a = 25^\circ C$ )

Parameter	Symbol	Limits	Unit
Power supply voltage	$V_{DD}$	- 0.3 ~ + 18	V
Power dissipation	$P_d$	1000 (DIP), 450 (SOP), 350 (SSOP)	mW
Operating temperature	$T_{opr}$	- 40 ~ + 85	$^\circ C$
Storage temperature	$T_{stg}$	- 55 ~ + 150	$^\circ C$
Input voltage	$V_{IN}$	- 0.3 ~ $V_{DD} + 0.3$	V

## ●Electrical characteristics

DC characteristics (unless otherwise noted,  $V_{SS} = 0V$ ,  $T_a = 25^\circ C$ )

Parameter	Symbol	Min.	Typ.	Max.	Unit	V <sub>DD</sub> (V)	Conditions	Measurement circuit
Input high level voltage	V <sub>IH</sub>	3.5	—	—	V	5	—	Fig.1
		7.0	—	—		10		
		11.0	—	—		15		
Input low level voltage	V <sub>IL</sub>	—	—	1.5	V	5	—	
		—	—	3.0		10		
		—	—	4.0		15		
Input high level current	I <sub>IH</sub>	—	—	0.3	μA	15	V <sub>IH</sub> = 15V	
Input low level current	I <sub>IL</sub>	—	—	-0.3	μA	15	V <sub>IL</sub> = 0V	
Output high level voltage	V <sub>OH</sub>	4.95	—	—	V	5	I <sub>O</sub> = 0mA	
		9.95	—	—		10		
		14.95	—	—		15		
Output low level voltage	V <sub>OL</sub>	—	—	0.05	V	5	I <sub>O</sub> = 0mA	
		—	—	0.05		10		
		—	—	0.05		15		
Output high level current	I <sub>OH</sub>	-0.44	—	—	mA	5	V <sub>OH</sub> = 4.6V	
		-1.1	—	—		10	V <sub>OH</sub> = 9.5V	
		-3.0	—	—		15	V <sub>OH</sub> = 13.5V	
Output low level current	I <sub>OL</sub>	0.44	—	—	mA	5	V <sub>OL</sub> = 0.4V	
		1.1	—	—		10	V <sub>OL</sub> = 0.5V	
		3.0	—	—		15	V <sub>OL</sub> = 1.5V	
Static current consumption	I <sub>DD</sub>	—	—	1	μA	5	—	
		—	—	2		10		
		—	—	4		5		
Hysteresis voltage	V <sub>H</sub>	0.15	—	0.6	V	5	—	Fig.1
		0.25	—	1.0		10		
		0.40	—	1.5		15		

Switching characteristics (unless otherwise noted,  $T_a = 25^\circ C$ ,  $V_{SS} = 0V$ ,  $C_L = 50pF$ )

Parameter	Symbol	Min.	Typ.	Max.	Unit	V <sub>DD</sub> (V)	Conditions	Measurement circuit
Output rise time	t <sub>TLH</sub>	—	100	—	ns	5	—	Fig.2
		—	50	—		10		
		—	40	—		15		
Output fall time	t <sub>THL</sub>	—	100	—	ns	5	—	Fig.2
		—	50	—		10		
		—	40	—		15		
Propagation delay time, "L" to "H"	t <sub>PLH</sub>	—	125	—	ns	5	—	Fig.2
		—	60	—		10		
		—	50	—		15		
Propagation delay time, "H" to "L"	t <sub>PHL</sub>	—	125	—	ns	5	—	Fig.2
		—	60	—		10		
		—	50	—		15		

● Measurement circuits

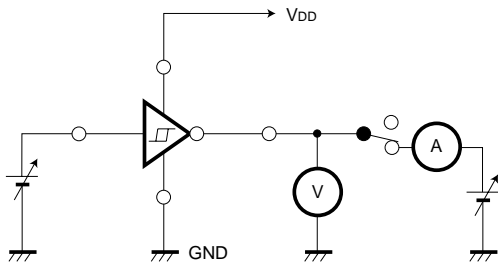

Fig.1 DC characteristics

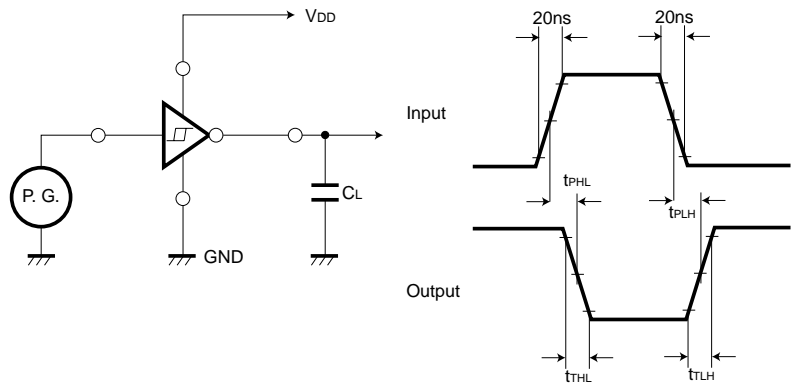

Fig.2 Switching characteristics

● Electrical characteristic curve

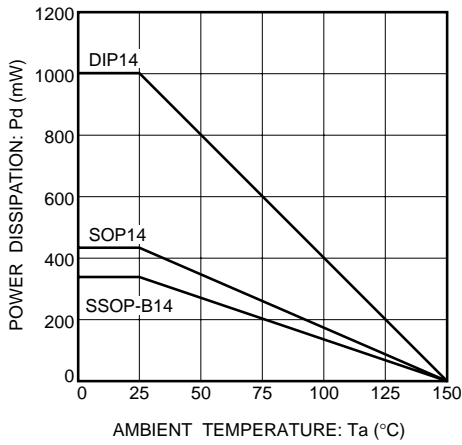

Fig.3 Power dissipation vs. Ta

● External dimensions (Units: mm)

