

# M57951L

HYBRID IC FOR DRIVING TRANSISTOR MODULES

## DESCRIPTION

M57951L is a Hybrid Integrated Circuit designed for driving Transistor Modules QM30DY, QM50DY, etc., in an Inverter application. This device operates as an isolation amplifier for Transistor Modules due to the electrical isolation between the input and output, and includes three independent circuits.

## FEATURES

- Three independent circuits are included.
- Isolation voltage:  $V_{iso}=2500V_{rms}$
- Each circuit can be driven by single power supply

## APPLICATION

To drive Transistor Modules for Inverter applications

## OUTLINE DRAWING

Dimensions in mm

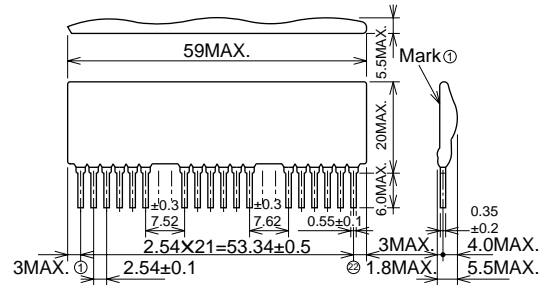

## BLOCK DIAGRAM

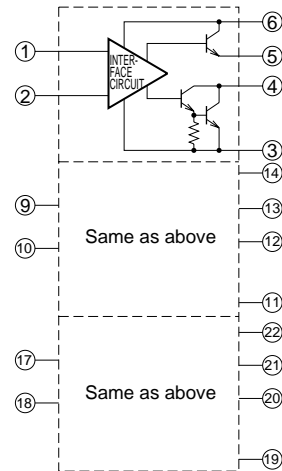

## CIRCUIT DIAGRAM

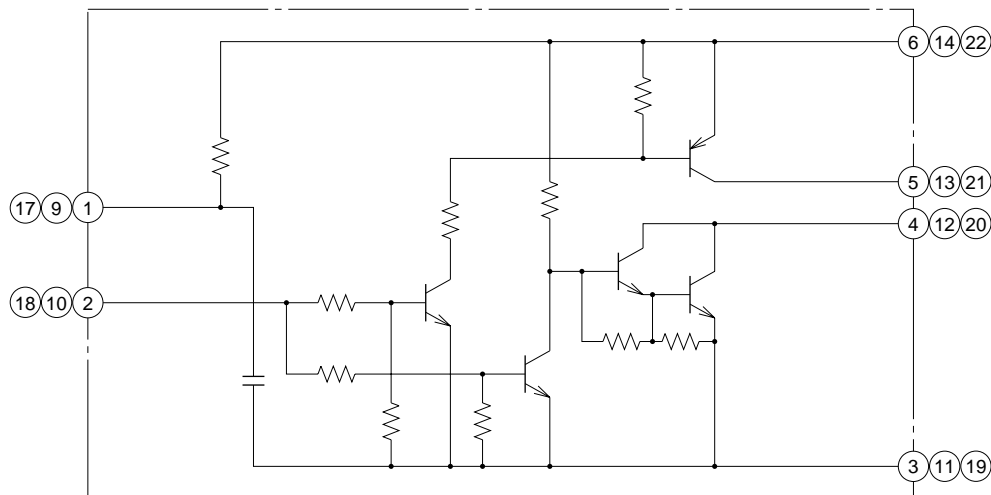

**ABSOLUTE MAXIMUM RATINGS** ( $T_a = -20 \sim +70^\circ\text{C}$ , unless otherwise noted)

Symbol	Parameter	Conditions	Ratings	Unit
VCC	Supply voltage	DC	14	V
IOH	Output current	DC	-0.8	A
IOLP		Pulse width 10 $\mu$ s, Freq. 2kHz, peak value	4	A
Viso	Isolation voltage	Sinewave voltage 60Hz/min. $T_a = 25^\circ\text{C}$	2500	Vrms
Tj	Junction temperature		125	$^\circ\text{C}$
Topg	Operating temperature		-20 ~ +70	$^\circ\text{C}$
Tstg	Storage temperature		-25 ~ +100	$^\circ\text{C}$

**ELECTRICAL CHARACTERISTICS** ( $T_a = 25^\circ\text{C}$ , VCC=10V, unless otherwise noted)

Symbol	Parameter	Test conditions	Limits			Unit
			Min.	Typ.	Max.	
IOH	"H" output current	$R_{ext} = 9\Omega$	-	-0.65	-	A
IOLP	"L" output peak current	$C_{ext} = 47\mu\text{F}$	-	3	-	A
PD	Internal power dissipation	$I_{OH} = -0.65\text{A}$ , $I_{OLP} = 2\text{A}$ , $f = 2\text{kHz}$ , D.F. = 50%	-	2.1	-	W
tPLH	"L-H" propagation delay time	$V_I = 0 \rightarrow 4\text{V}$ , $T_j = 100^\circ\text{C}$	-	5	10	$\mu\text{s}$
tr	"L-H" rise time	$V_I = 0 \rightarrow 4\text{V}$ , $T_j = 100^\circ\text{C}$	-	-	1	$\mu\text{s}$
tPHL	"H-L" propagation delay time	$V_I = 5 \rightarrow 0\text{V}$ , $T_j = 100^\circ\text{C}$	-	8	15	$\mu\text{s}$
tf	"H-L" fall time	$V_I = 5 \rightarrow 0\text{V}$ , $T_j = 100^\circ\text{C}$	-	-	1	$\mu\text{s}$

PERFORMANCE CURVES

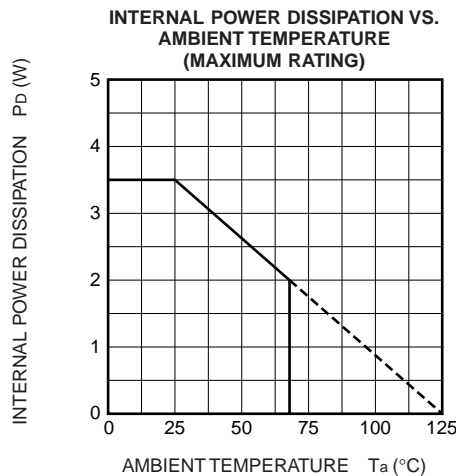
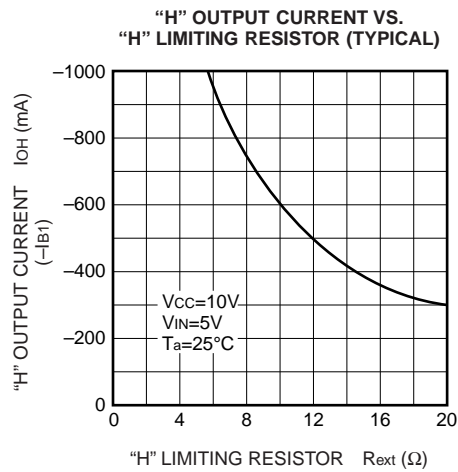
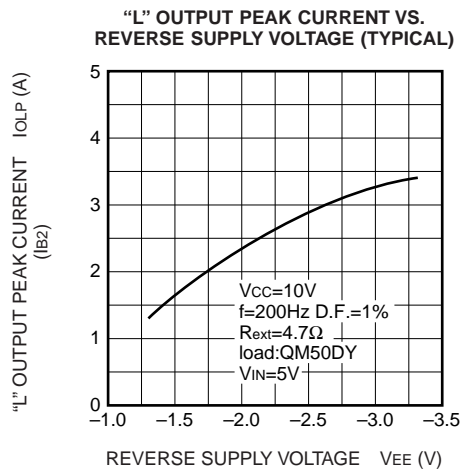
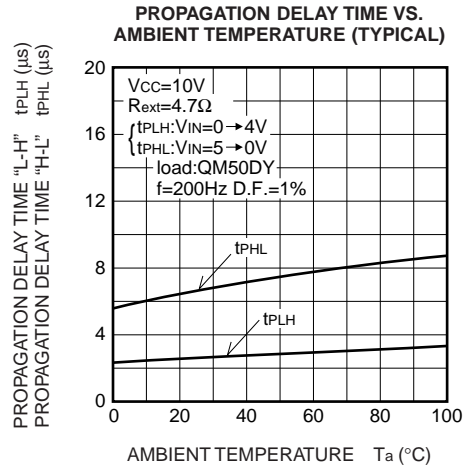
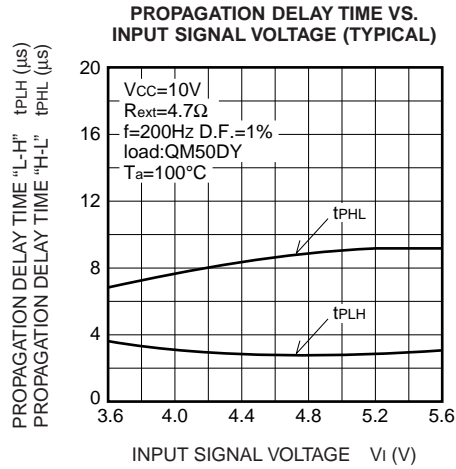

**TEST CIRCUIT AND APPLICATION CIRCUIT EXAMPLE**

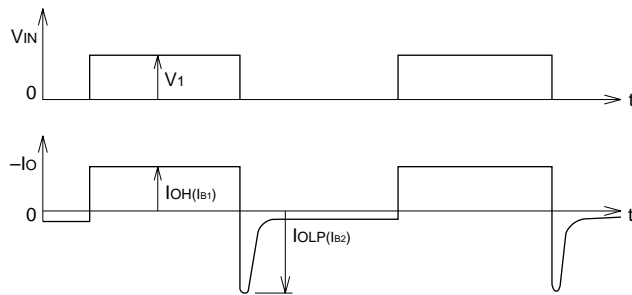
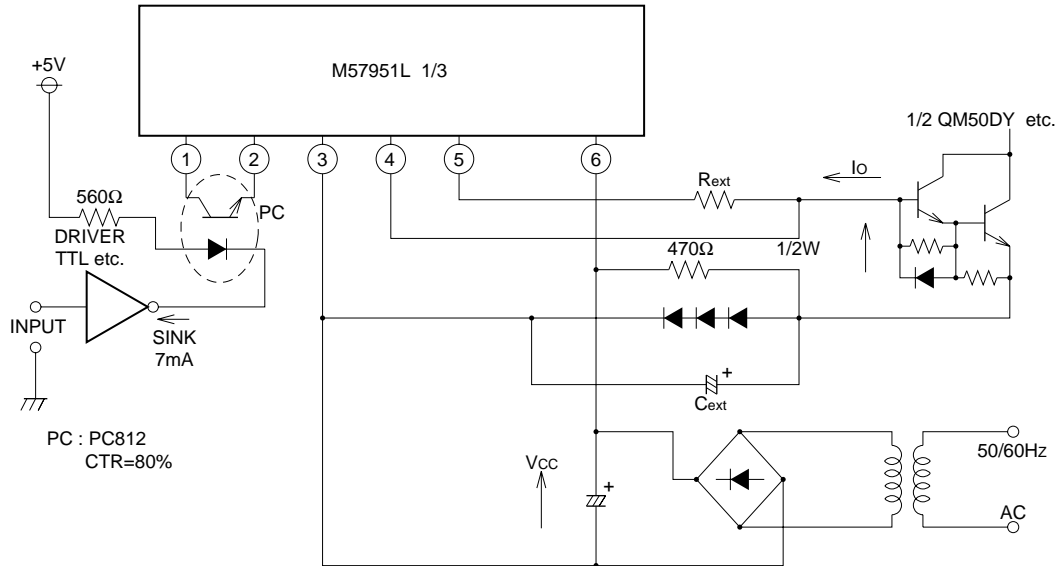

**Note:** IOH and IOLP correspond to base forward current IB1 and base reverse current IB2 of the transistor modules to be driven respectively.