

M57925L

HYBRID IC FOR DRIVING TRANSISTOR MODULES

DESCRIPTION

M57925L is a Hybrid Integrated Circuit designed for driving Transistor Modules QM30DY, QM50DY, etc., in an Inverter application. This device operates as an isolation amplifier for Transistor Modules due to the electrical isolation between the input and output, and features a small outline of 10-pin SIP.

FEATURES

- Electrical isolation between input and output with integrated opto-coupler. $V_{iso}=2500V_{rms}$
- Propagation delay time $t_{PLH}=2\mu s$ (TYP)
- $t_{PLH}=4\mu s$ (TYP)
- Large load and sink current driving capability
- $I_{OH}=-1A$ (MAX)
- $I_{OLP}=-3A$ (MAX)
- Applicable with TTL input
- Small outline, 10-pin SIP package

APPLICATION

To drive Transistor Modules for Inverter applications

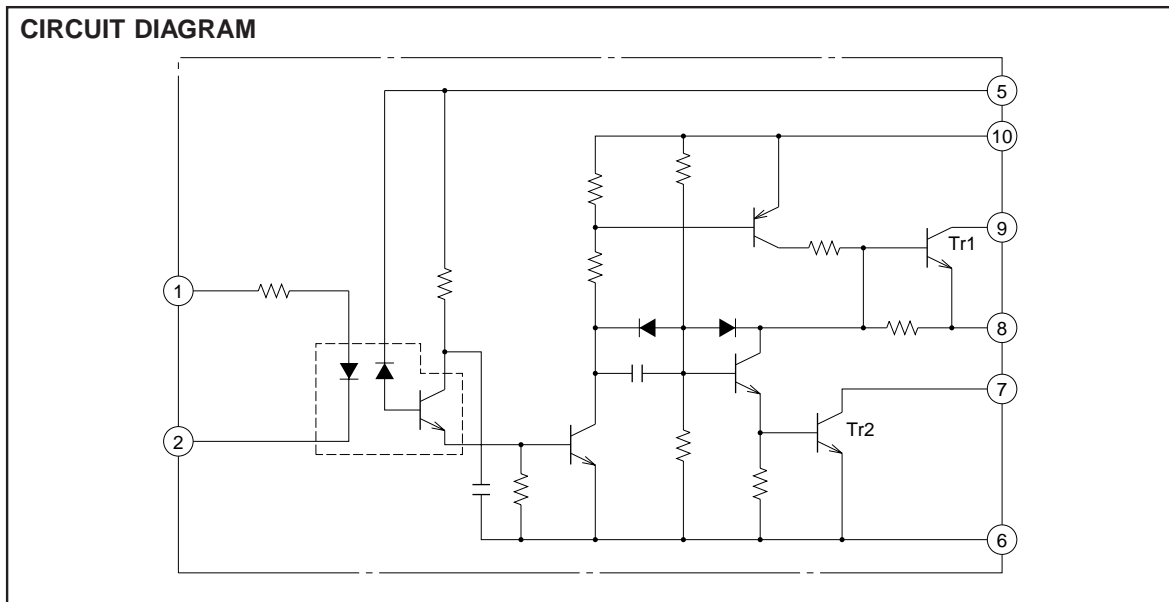
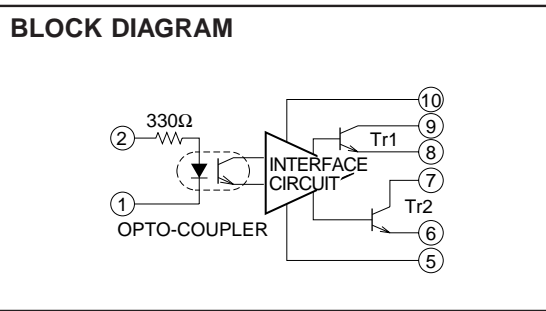
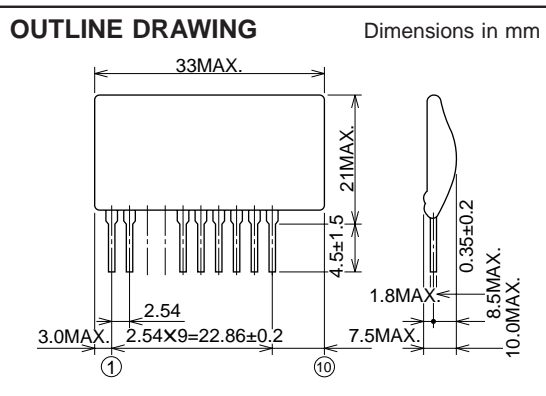

ABSOLUTE MAXIMUM RATINGS ($T_a = -20 \sim +70^\circ\text{C}$, unless otherwise noted)

Symbol	Parameter	Conditions	Ratings	Unit
VCC	Supply voltage	DC	14	V
VEE	Supply voltage	DC	-6	V
V _I	Input voltage	Between terminals ① and ②	-1 ~ 7	V
I _{OH}	Output current		-1	A
I _{OLP}		Pulse width 10 μ s, Freq. 2kHz, peak value	3	A
V _{iso}	Isolation voltage	Sinewave voltage 60Hz/min. $T_a = 25^\circ\text{C}$	2500	V _{rms}
T _j	Junction temperature		100	$^\circ\text{C}$
T _{opg}	Operating temperature		-20 ~ +70	$^\circ\text{C}$
T _{stg}	Storage temperature		-25 ~ +100	$^\circ\text{C}$

ELECTRICAL CHARACTERISTICS ($T_a = 25^\circ\text{C}$, $V_{CC} = 8\text{V}$, unless otherwise noted)

Symbol	Parameter	Test conditions	Limits			Unit
			Min.	Typ.	Max.	
I _{IH}	"H" input current	V _I =5V	-	12	-	mA
I _{OH}	"H" output current	R _{ext} =9 Ω	-0.8	-	-	A
I _{OLP}	"L" output peak current	C _{ext} =10 μ F, R ₂ =1 Ω	-	2	-	A
P _D	Internal power dissipation	I _{OH} =-0.5A, I _{OLP} =1A, f=2kHz, D.F.=50%	-	0.35	-	W
t _{PLH}	"L-H" propagation delay time	V _I =0 \rightarrow 4V, T _j =100 $^\circ\text{C}$	-	2	4	μ s
t _r	"L-H" rise time	V _I =0 \rightarrow 4V, T _j =100 $^\circ\text{C}$	-	-	2	μ s
t _{PHL}	"H-L" propagation delay time	V _I =5 \rightarrow 0V, T _j =100 $^\circ\text{C}$	-	4	6	μ s
t _f	"H-L" fall time	V _I =5 \rightarrow 0V, T _j =100 $^\circ\text{C}$	-	-	3	μ s

PERFORMANCE CURVES

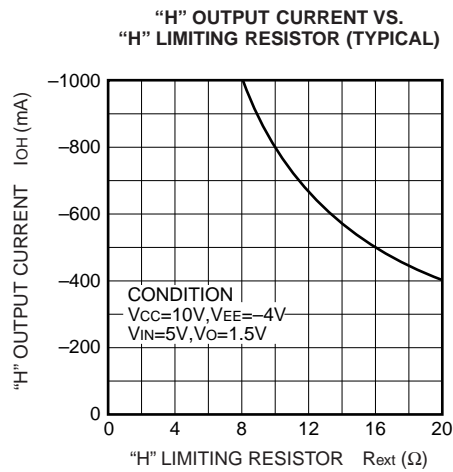
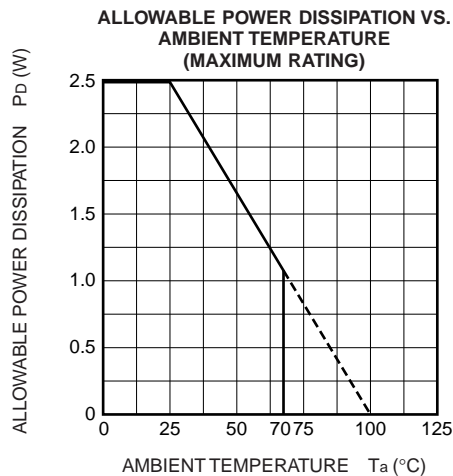
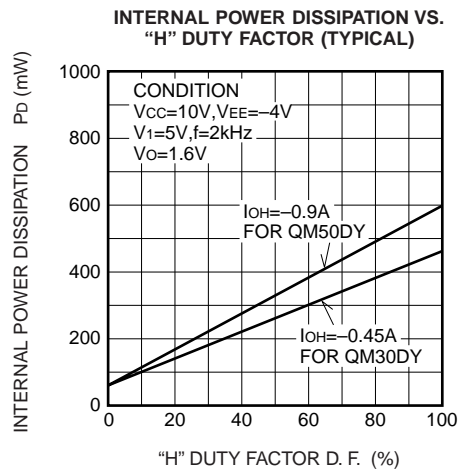
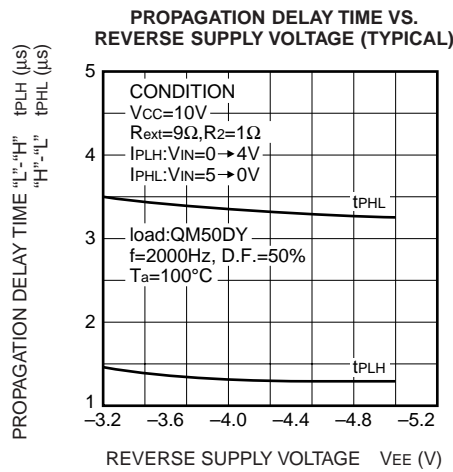
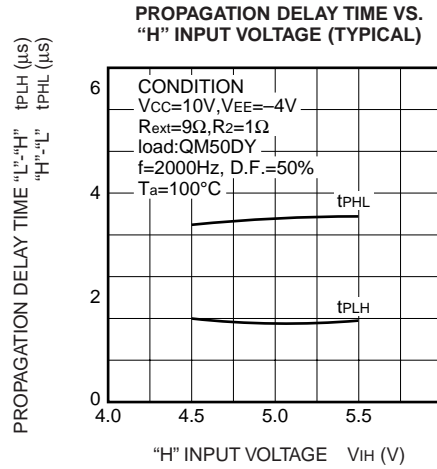
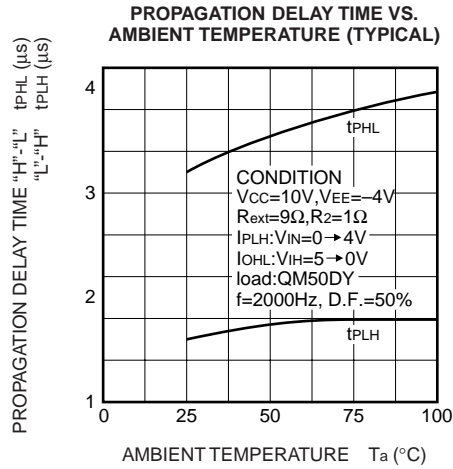

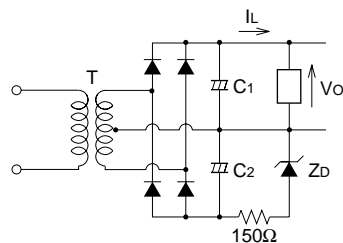
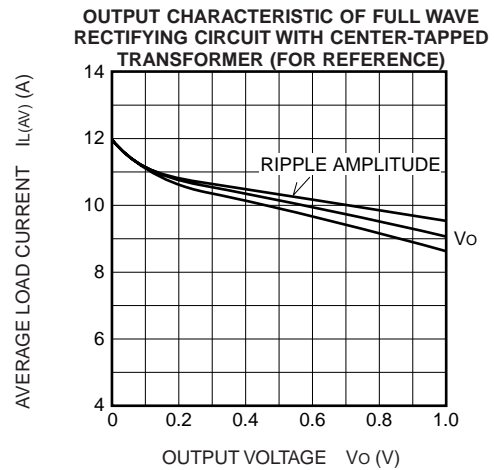
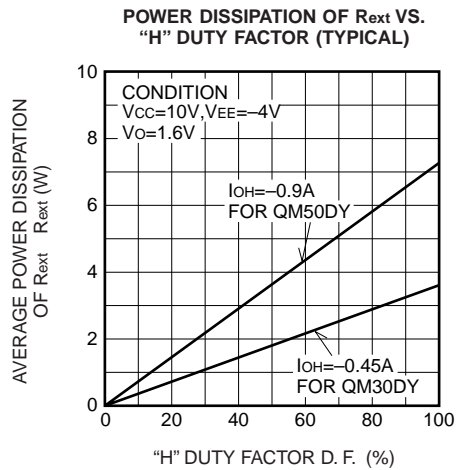
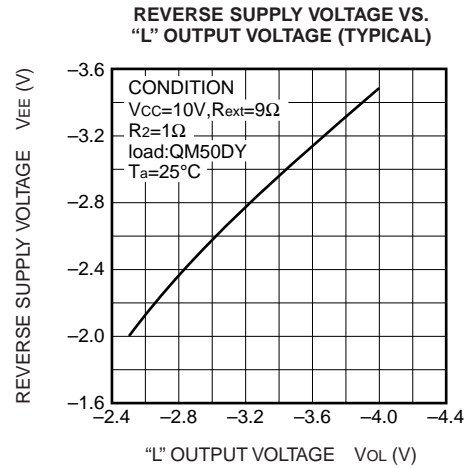
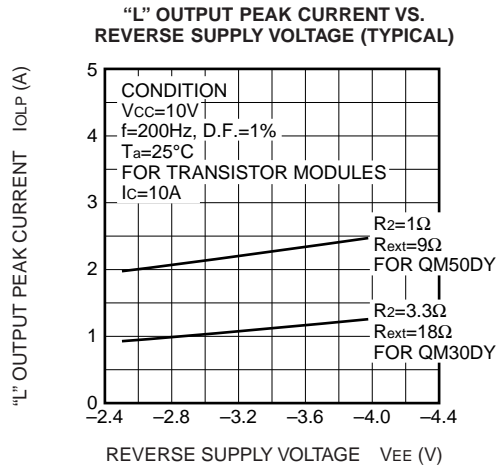

T: 8V, 1AX2 CENTER-TAPPED TRANSFORMER
 C1: 4700 μF , C2: 470 μF

EXPLANATION OF FUNCTION

(cf. Fig. 2, 3, 4, and 5)

(1) With low input level ($V_{in}=0 \sim 1V$)

Tr1 OFF, Tr2 ON

The base terminal of transistor module is reverse biased with respect to its emitter by reverse power supply VEE.

(2) With high input level ($V_{in}=4 \sim 5V$)

Tr1 ON, Tr2 OFF

The base terminal of transistor module is forward biased and driven by the current I_{OH} through the resistor R_{ext} .

(3) With low input level ($V_{in}=0 \sim 1V$)

Tr1 OFF, Tr2 ON

The base terminal of transistor module is reverse biased as stated in (1) after flowing reverse recovery pulse current I_{OLP} . The steady reverse base current is limited by the internal base-emitter resistor R_{BE} of the transistor module.

Typical application circuit

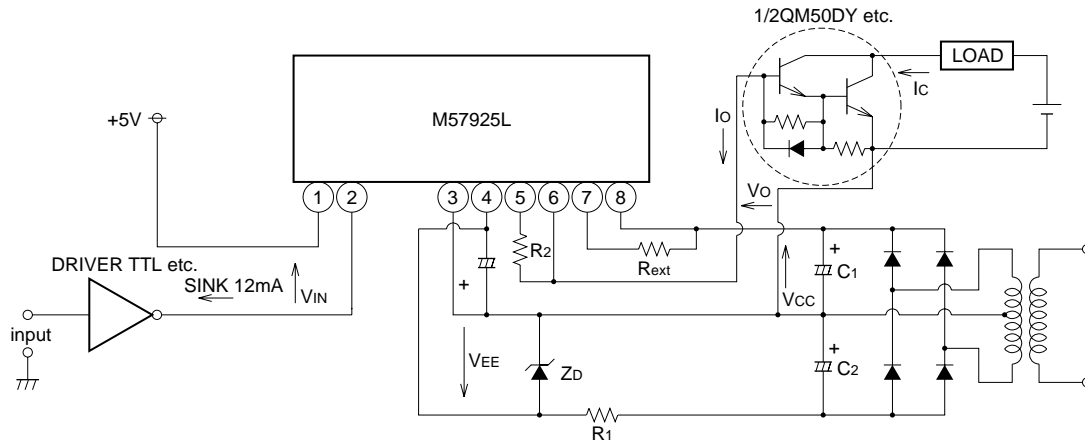

Typical operating waveform

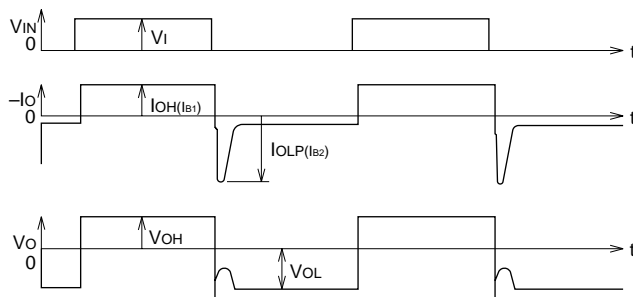

Note: I_{OH} and I_{OLP} correspond to base forward current I_{b1} and base reverse current I_{b2} of the transistor module to be driven respectively.