

M57721L

350-400MHz, 12.5V, 7W, FM PORTABLE RADIO

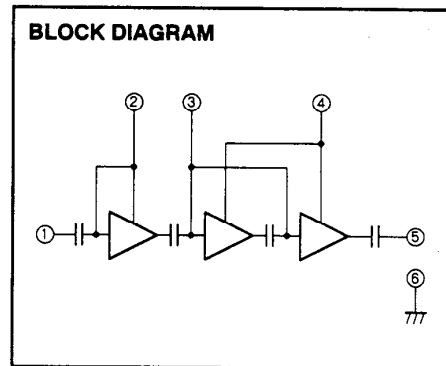
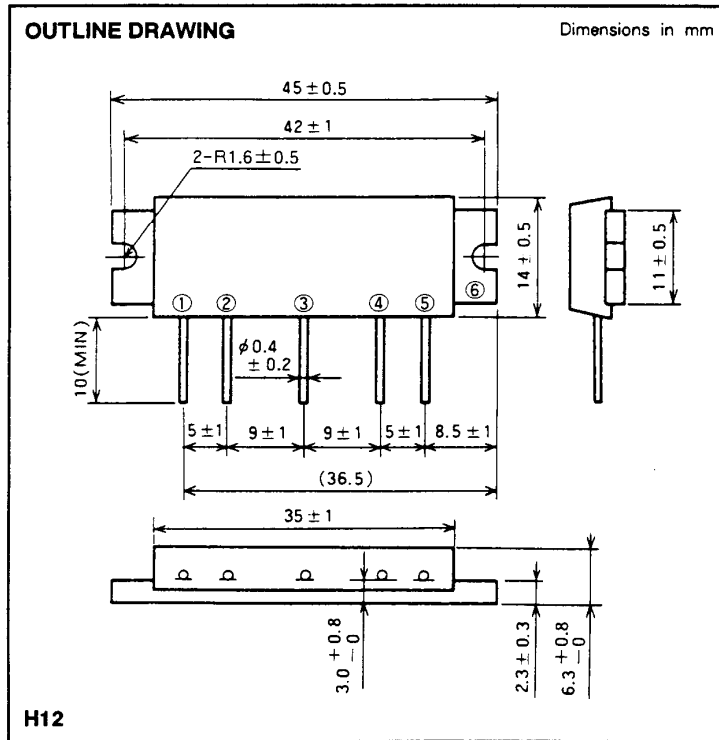

- PIN :
- ① Pin : RF INPUT
 - ② Vcc1 : 1st. DC SUPPLY
 - ③ Vbb : BASE BIAS SUPPLY
 - ④ Vcc2 : 2nd. DC SUPPLY
 - ⑤ Po : RF OUTPUT
 - ⑥ GND : FIN

ABSOLUTE MAXIMUM RATINGS (T_c = 25 °C unless otherwise noted)

Symbol	Parameter	Conditions	Ratings	Unit
V _{cc}	Supply voltage		16	V
V _{bb}	Base bias		6	V
I _{cc}	Total current		4	A
P _{in(max)}	Input power	Z _G = Z _L = 50 Ω	20	mW
P _{o(max)}	Output power	Z _G = Z _L = 50 Ω	10	W
T _{c(OP)}	Operation case temperature		- 30 to 110	°C
T _{stg}	Storage temperature		- 40 to 110	°C

Note. Above parameters are guaranteed independently.

ELECTRICAL CHARACTERISTICS (T_c = 25 °C unless otherwise noted)

Symbol	Parameter	Test conditions	Limits		Unit
			Min	Max	
f	Frequency range	V _{cc1} = V _{cc2} = 12.5V V _{bb} = 5V P _{in} = 10mW Z _G = Z _L = 50 Ω	350	400	MHz
P _o	Output power		7		W
η _T	Total efficiency		40		%
2f _o	2nd. harmonic			- 30	dBc
3f _o	3rd. harmonic			- 35	dBc
ρ _{in}	Input VSWR			2.5	-
-	Load VSWR tolerance	V _{cc1} = V _{cc2} = 13.2V, V _{bb} = 5V P _o = 7W (P _{in} : controlled) Load VSWR ≥ 20 : 1 (All phase) Z _G = 50Ω	No degradation or destroy		-

Note. Above parameters, ratings, limits and conditions are subject to change.

TYPICAL PERFORMANCE DATA

OUTPUT POWER, TOTAL EFFICIENCY, INPUT VSWR VS. FREQUENCY CHARACTERISTICS

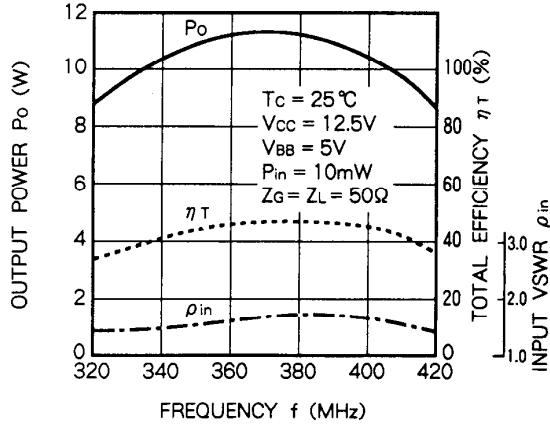

OUTPUT POWER, TOTAL EFFICIENCY, INPUT VSWR VS. FREQUENCY CHARACTERISTICS

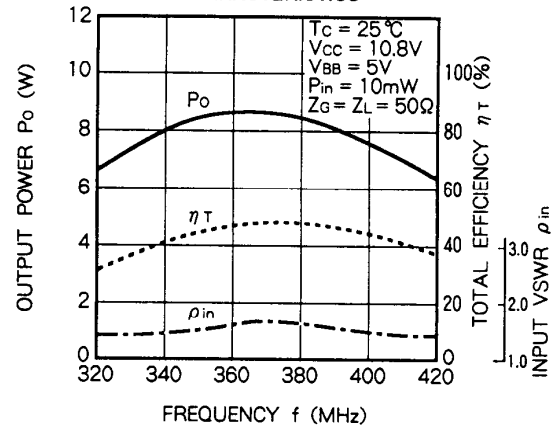

OUTPUT POWER, TOTAL EFFICIENCY, INPUT VSWR VS. FREQUENCY CHARACTERISTICS

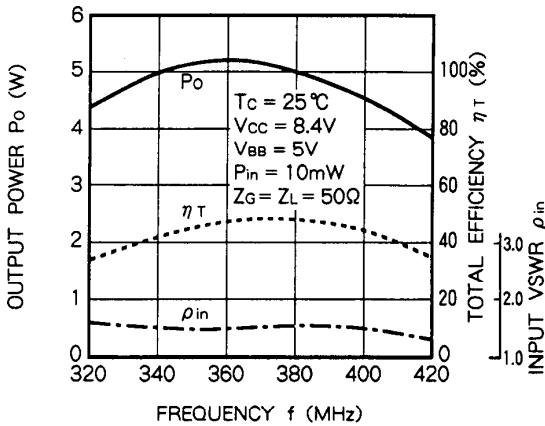

OUTPUT POWER, TOTAL EFFICIENCY, INPUT VSWR VS. FREQUENCY CHARACTERISTICS

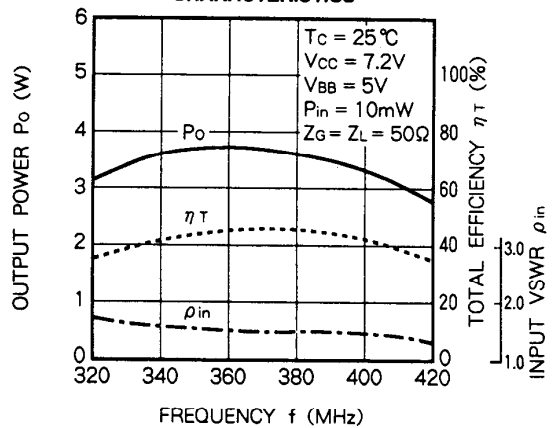

OUTPUT POWER, TOTAL CURRENT, 1st CURRENT VS. INPUT POWER CHARACTERISTICS

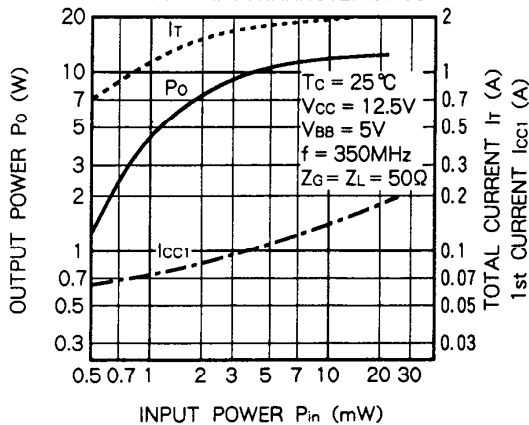

OUTPUT POWER, TOTAL CURRENT, 1st CURRENT VS. INPUT POWER CHARACTERISTICS

