

Econo IPM series

600V / 100A 7 in one-package

Features

- Temperature protection provided by directly detecting the junction temperature of the IGBTs
- Low power loss and soft switching
- High performance and high reliability IGBT with overheating protection
- Higher reliability because of a big decrease in number of parts in built-in control circuit



Maximum ratings and characteristics

- Absolute maximum ratings(at Tc=25°C unless otherwise specified)

Item	Symbol	Rating		Unit		
		Min.	Max.			
Bus voltage	DC	V _{DC}	0	450	V	
	Surge	V _{DC(surge)}	0	500	V	
	Short operating	V _{SC}	200	400	V	
Collector-Emitter voltage *1		V _{CEs}	0	600	V	
Inverter	Collector current	DC	I _c	-	100	A
		1ms	I _{cP}	-	200	A
		Duty=72.3% *2	-I _c	-	100	A
	Collector power dissipation	One transistor *3	P _c	-	347	W
	Collector current	DC	I _c	-	50	A
		1ms	I _{cP}	-	100	A
	Forward current diode		I _F	-	50	A
	Collector power dissipation	One transistor *3	P _c	-	198	W
Supply voltage of Pre-Driver *4		V _{CC}	-0.5	20	V	
Input signal voltage *5		V _{in}	-0.5	V _{CC} +0.5	V	
Input signal current		I _{in}	-	3	mA	
Alarm signal voltage *6		V _{ALM}	-0.5	V _{CC}	V	
Alarm signal current *7		I _{ALM}	-	20	mA	
Junction temperature		T _J	-	150	°C	
Operating case temperature		T _{opr}	-20	100	°C	
Storage temperature		T _{stg}	-40	125	°C	
Solder temperature *8		T _{sol}	-	260	°C	
Isolating voltage (Terminal to base, 50/60Hz sine wave 1min.)		V _{iso}	-	AC2500	V	
Screw torque	Mounting (M5)		-	3.5	N·m	

Note

*1 : V_{CEs} shall be applied to the input voltage between terminal P and U or ,u or W, N and U or V or W

*2 : 125°C/FWD R_{th(j-c)}/(I_c x V_F MAX)=125/0.665/(100 x 2.6) x 100=72.3%

*3 : P_c=125°C/IGBT R_{th(j-c)}=125/0.36=347W [Inverter]

P_c=125°C/IGBT R_{th(j-c)}=125/0.63=198W [Breake]

*4 : V_{CC} shall be applied to the input voltage between terminal No.4 and 1, 8 and 5, 12 and 9, 14 and 13

*5 : V_{in} shall be applied to the input voltage between terminal No.3 and 1, 7 and 5, 11 and 9, 16,17,18 and 13.

*6 : V_{ALM} shall be applied to the voltage between terminal No.2 and 1, No6 and 5, No10 and 9, No.19 and 13.

*7 : I_{ALM} shall be applied to the input current to terminal No.2,6,10 and 19.

*8 : Immersion time 10±1sec.

Electrical characteristics (at Tc=Tj=25°C, Vcc=15V unless otherwise specified.)

● Main circuit

Item		Symbol	Condition	Min.	Typ.	Max.	Unit	
Inverter	Collector current at off signal input	ICES	VCE=600V Vin terminal open.	-	-	1.0	mA	
	Collector-Emitter saturation voltage	VCE(sat)	Ic=100A	Terminal	-	-	2.3	V
				Chip	-	1.8	-	
	Forward voltage of FWD	VF	-Ic=100A	Terminal	-	-	2.6	V
Chip				-	1.6	-		
Brake	Collector current at off signal input	ICES	VCE=600V Vin terminal open.	-	-	1.0	mA	
	Collector-Emitter saturation voltage	VCE(sat)	Ic=50A	Terminal	-	-	2.2	V
				Chip	-	1.75	-	
	Forward voltage of Diode	VF	-Ic=50A	Terminal	-	-	3.3	V
Chip				-	1.9	-		
Turn-on time	ton	VDC=300V, Tj=125°C		1.2	-	-	μs	
Turn-off time	toff	IC=100A Fig.1, Fig.6		-	-	3.6		
Reverse recovery time	trr	VDC=300V, IC=100A Fig.1, Fig.6		-	-	0.3		
Maximum Avalanche Energy (A non-repetition)	PAV	Internal wiring inductance=50nH Main circuit wiring inductance=54nH		100	-	-	mJ	

● Control circuit

Item	Symbol	Condition	Min.	Typ.	Max.	Unit
Supply current of P-line side pre-driver(one unit)	Iccp	Switching Frequency : 0 to 15kHz	-	-	18	mA
Supply current of N-line side pre-driver	ICCN	Tc=-20 to 125°C Fig.7	-	-	65	mA
Input signal threshold voltage (on/off)	Vin(th)	ON	1.00	1.35	1.70	V
		OFF	1.25	1.60	1.95	V
Input zener voltage	VZ	Rin=20k ohm	-	8.0	-	V
Alarm signal hold time	tALM	Tc=-20°C Fig.2	1.1	-	-	ms
		Tc=25°C Fig.2	-	2.0	-	ms
		Tc=125°C Fig.2	-	-	4.0	ms
Current limit resistor	RALM	Alarm terminal	1425	1500	1575	ohm

● Protection Section (Vcc=15V)

Item	Symbol	Condition	Min.	Typ.	Max.	Unit
Over Current Protection Level of Inverter circuit	Ioc	Tj=125°C	150	-	-	A
Over Current Protection Level of Brake circuit	Ioc	Tj=125°C	75	-	-	A
Over Current Protection Delay time	tDOC	Tj=125°C	-	5	-	μs
SC Protection Delay time	tsc	Tj=125°C Fig.4	-	-	8	μs
IGBT Chip Over Heating	TjOH	Surface of IGBT chips	150	-	-	°C
Over Heating Protection Hysteresis	TjH		-	20	-	°C
Under Voltage Protection Level	VUV		11.0	-	12.5	V
Under Voltage Protection Hysteresis	VH		0.2	0.5	-	V

● Thermal characteristics(Tc=25°C)

Item	Symbol		Min.	Typ.	Max.	Unit	
Junction to Case thermal resistance *9	Inverter	IGBT	Rth(j-c)	-	-	0.36	°C/W
		FWD	Rth(j-c)	-	-	0.665	°C/W
	Brake	IGBT	Rth(j-c)	-	-	0.63	°C/W
Case to fin thermal resistance with compound	Rth(c-f)		-	0.05	-	-°C/W	

*9 For 1device, Case is under the device

● Noise Immunity (VDC=300V, Vcc=15V, Test Circuit Fig.5)

Item	Condition	Min.	Typ.	Max.	Unit
Common mode rectangular noise	Pulse width 1μs, polarity ±, 10minuets Judge : no over-current, no miss operating	±2.0	-	-	kV
Common mode lightning surge	Rise time 1.2μs, Fall time 50μs Interval 20s, 10 times Judge : no over-current, no miss operating	±5.0	-	-	kV

● Recommendable value

Item	Symbol	Min.	Typ.	Max.	Unit
DC Bus Voltage	VDC	-	-	400	V
Operating Supply Voltage of Pre-Driver	VCC	13.5	15.0	16.5	V
Screw torque (M5)	-	2.5	-	3.0	Nm

● Weight

Item	Symbol	Min.	Typ.	Max.	Unit
Weight	Wt	-	270	-	g

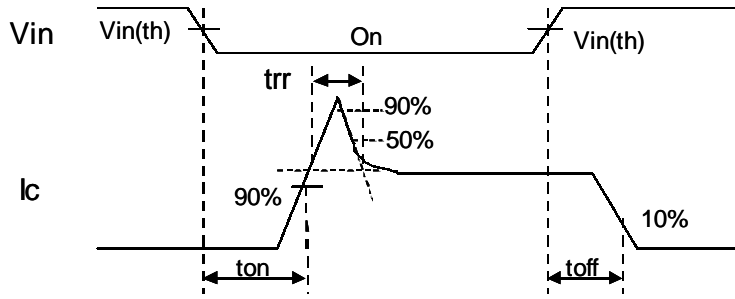
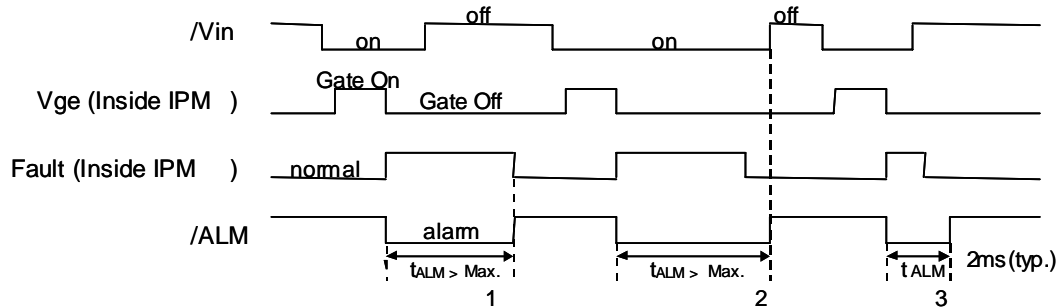

Figure 1. Switching Time Waveform Definitions



Fault : Over-current, Over-heat or Under-voltage

Figure 2. Input/Output Timing Diagram

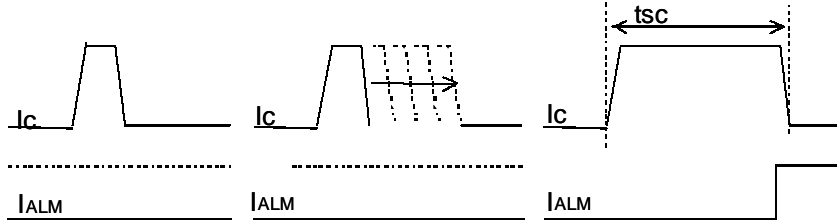

Figure.4 Definition of tsc

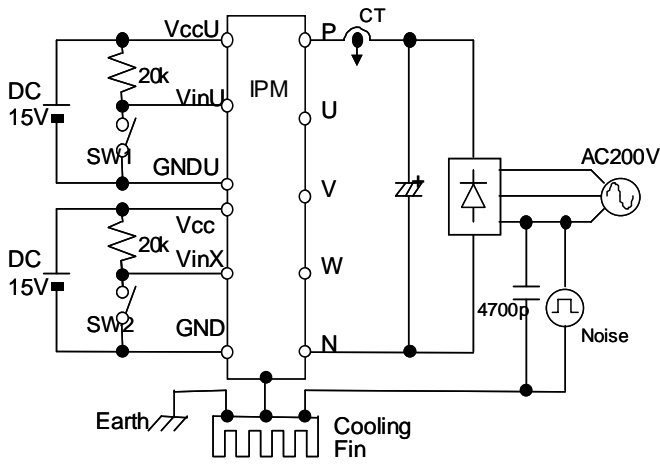

Figure 5. Noise Test Circuit

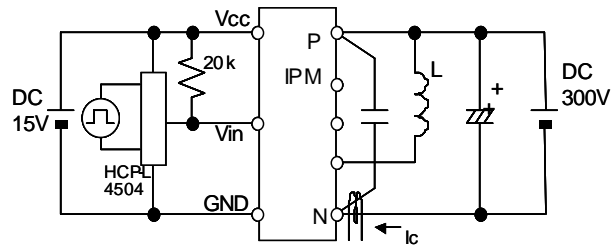

Figure 6. Switching Characteristics Test Circuit

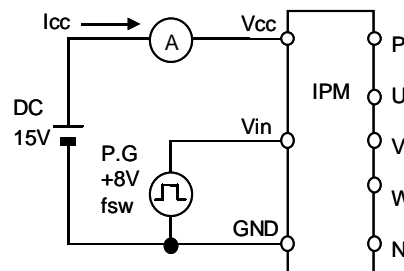
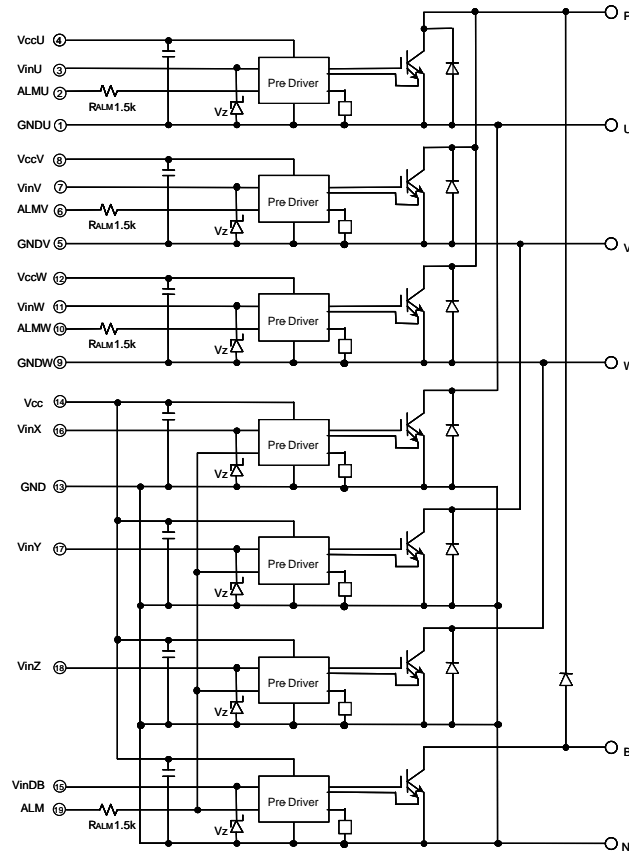

Figure 7. Icc Test Circuit

Block diagram



Pre-drivers include following functions

1. Amplifier for driver
2. Short circuit protection
3. Under voltage lockout circuit
4. Over current protection
5. IGBT chip over heating protection

Outline drawings, mm

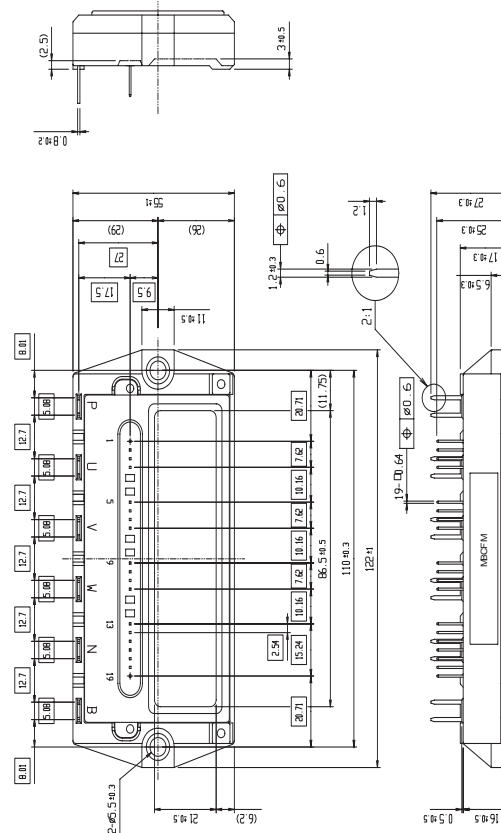

Mass : 270g

Characteristics

Control circuit characteristics (Representative)

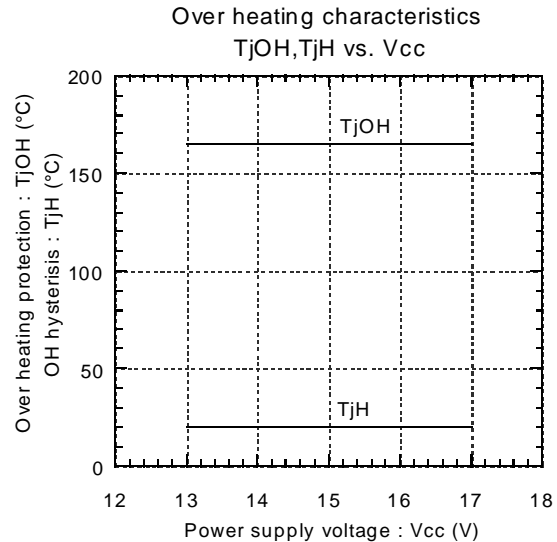
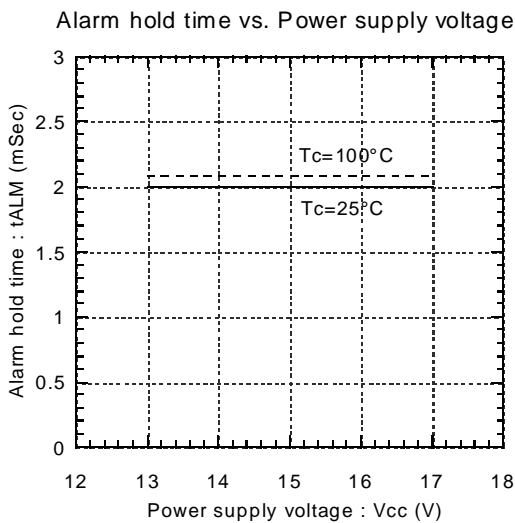
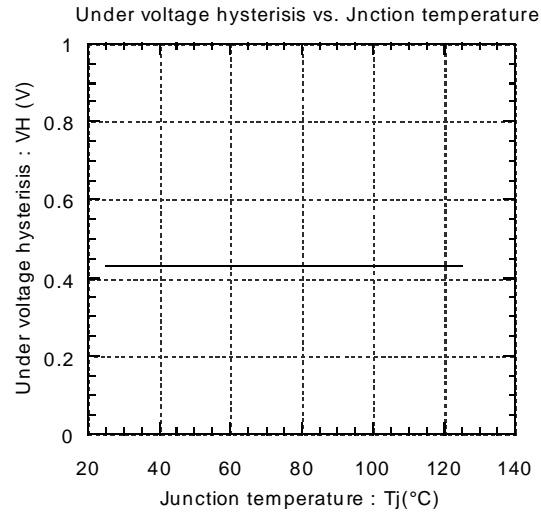
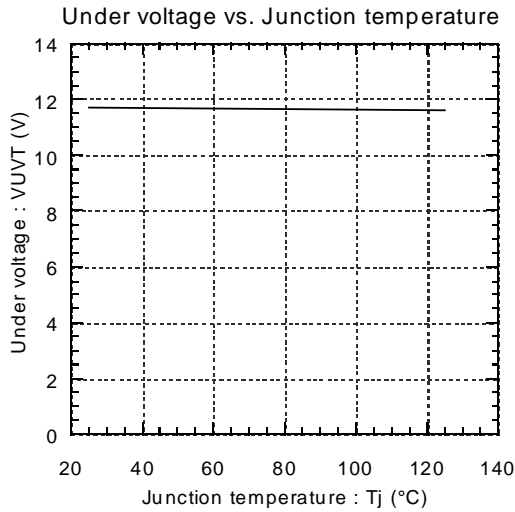
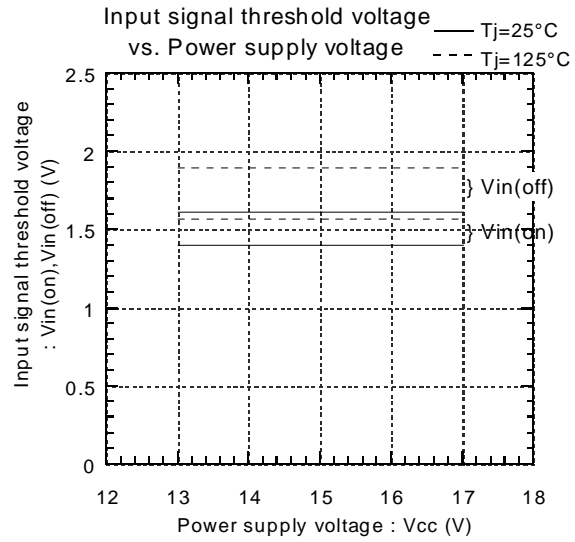
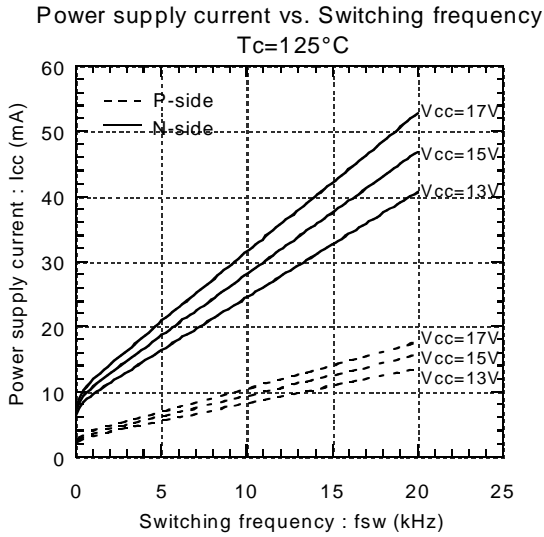

● Main circuit characteristics (Representative)

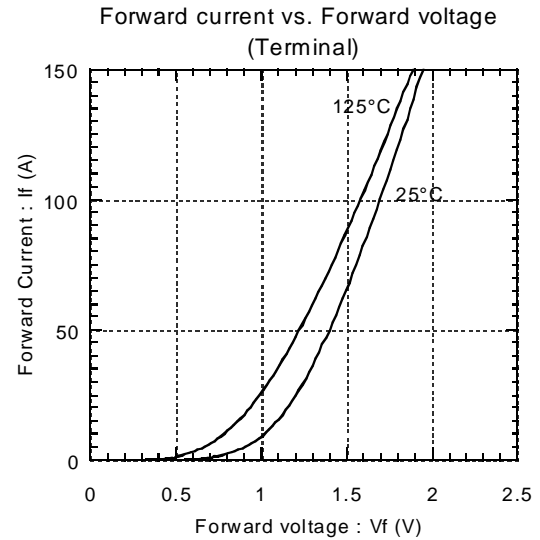
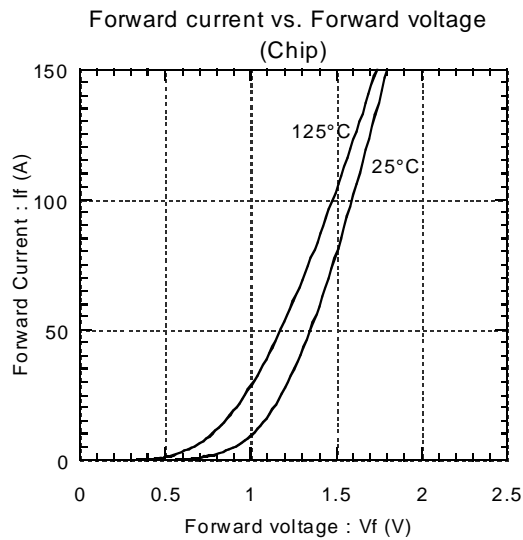
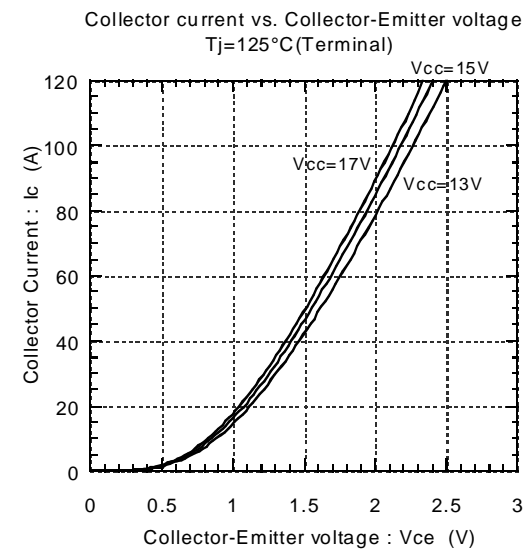
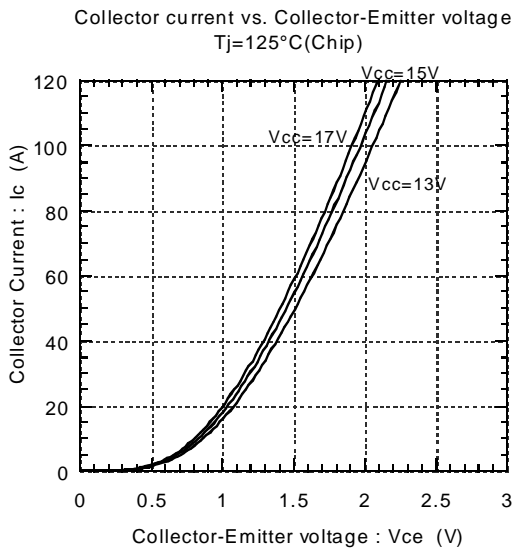
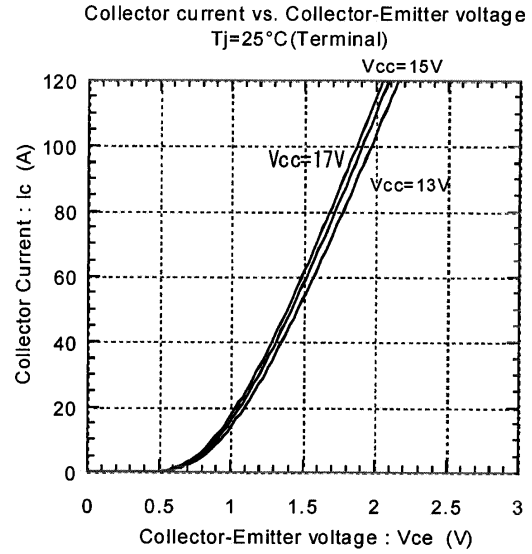
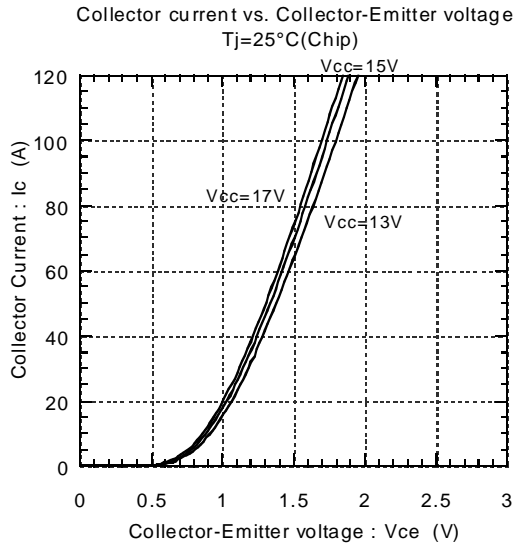

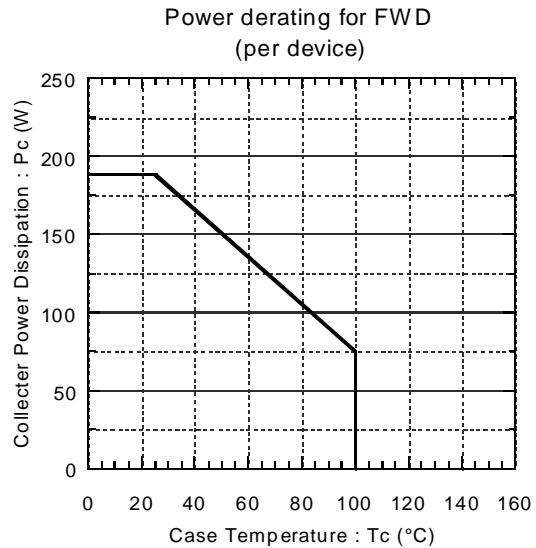
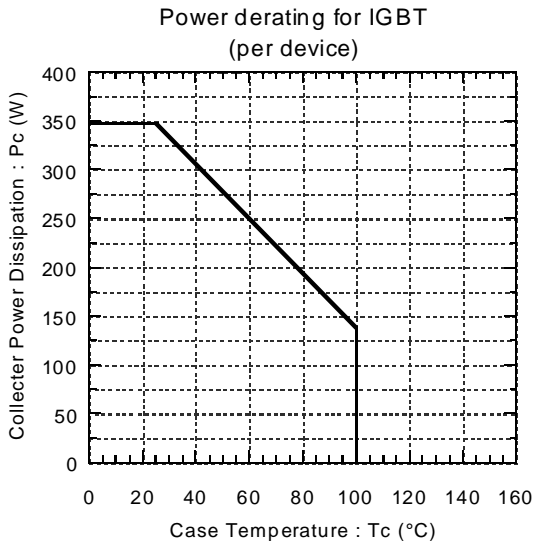
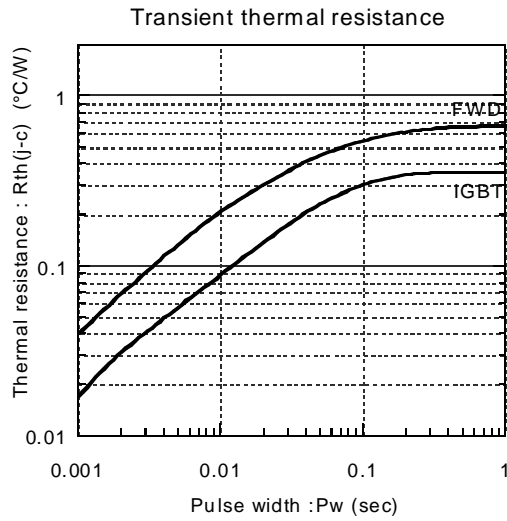
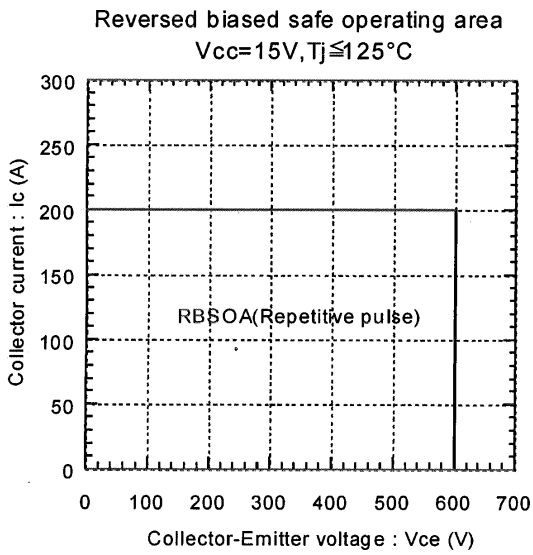
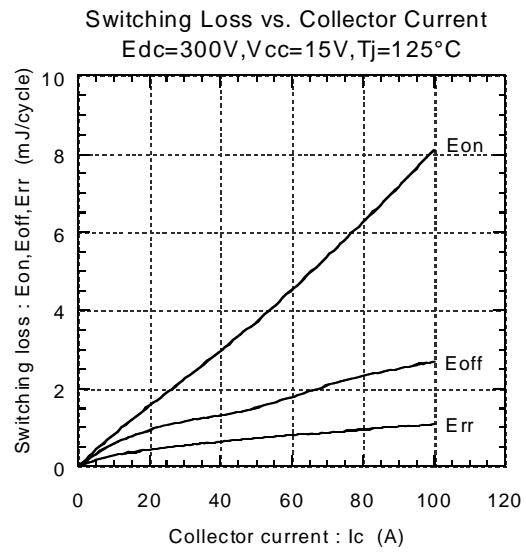
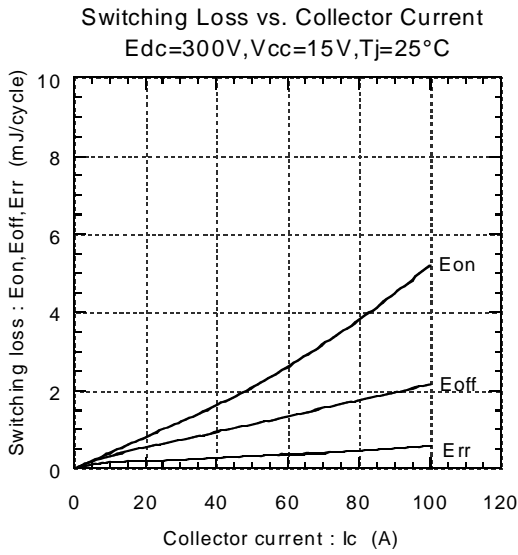

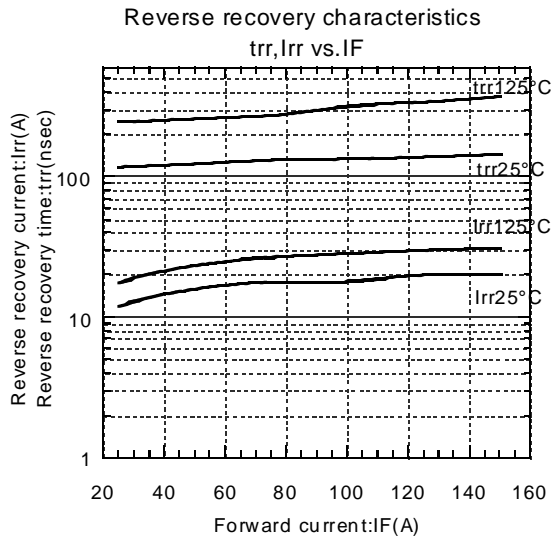
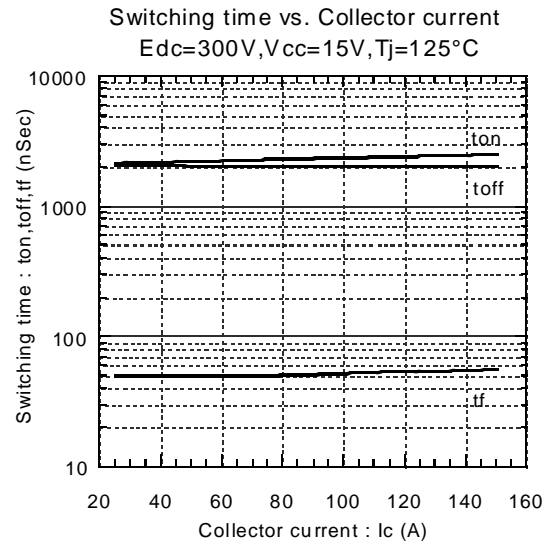
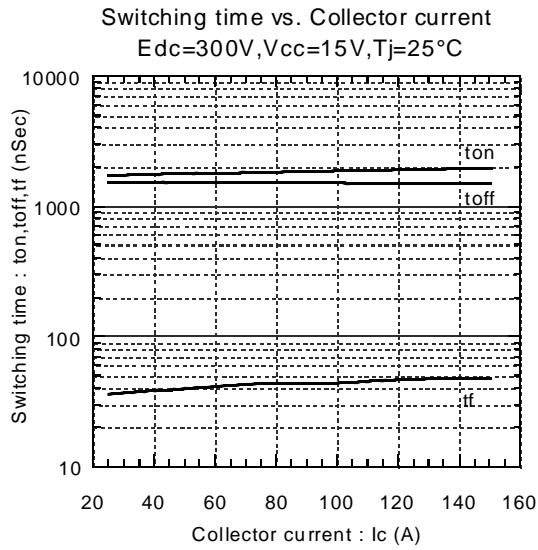

Characteristics

Dynamic Brake Characteristics (Representative)

Collector current vs. Collector-Emitter voltage
T_j=25°C

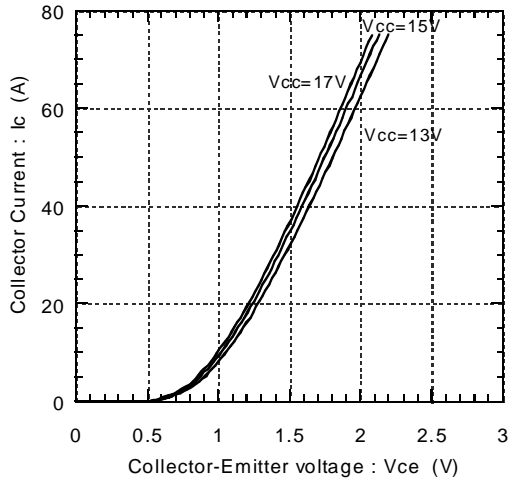

Collector current vs. Collector-Emitter voltage
T_j=125°C

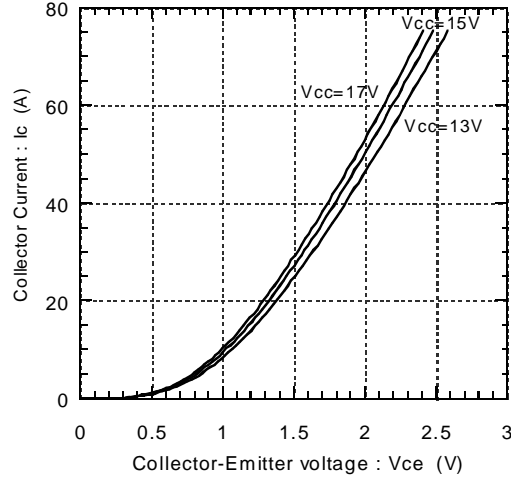

Transient thermal resistance

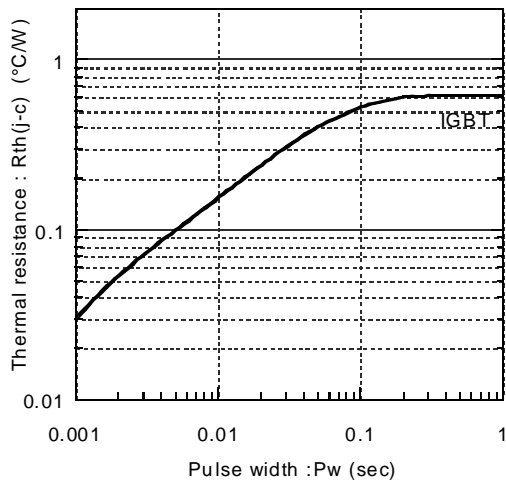

Reversed biased safe operating area
V_{cc}=15V, T_j ≤ 125°C

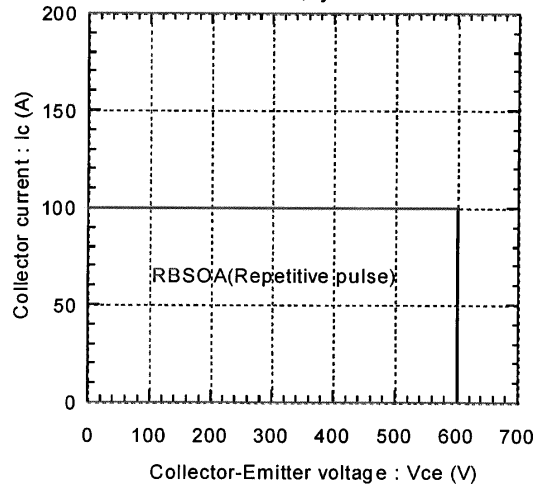

Power derating for IGBT
(per device)

