

Hex inverter

BU4069UB / BU4069UBF / BU4069UBFV

The BU4069UB, BU4069UBF and BU4069UBFV are six-circuit inverters with no buffers. A single-stage gate configuration reduces the propagation time.

●Features

- 1) Low power dissipation.
- 2) Wide range of operating power supply voltages.
- 3) High input impedance.
- 4) High fan-out.
- 5) Direct drive of 2 L-TTL inputs and 1 LS-TTL input.

●Logic circuit diagram

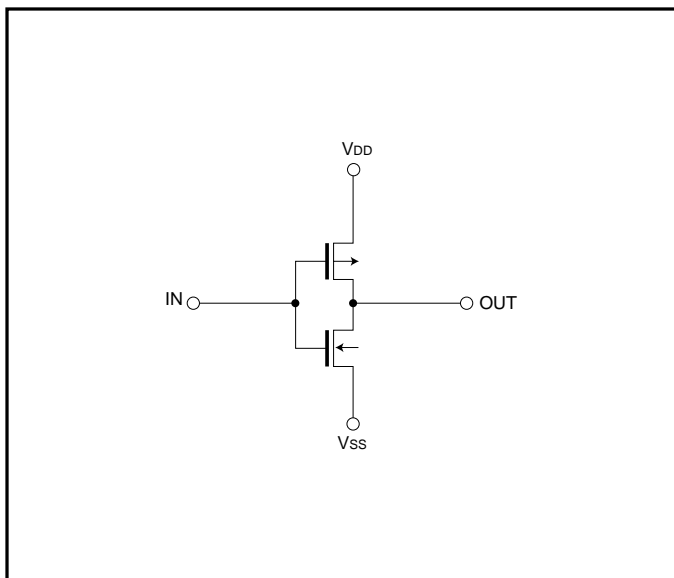

●Block diagram

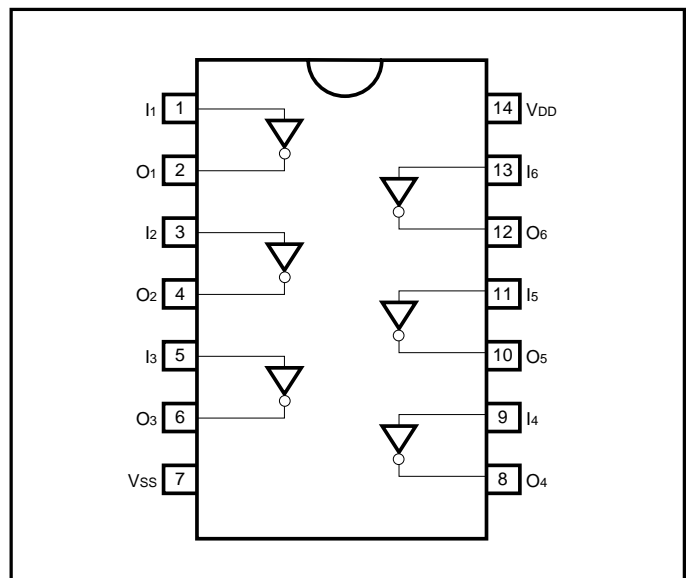

●Absolute maximum ratings ($V_{SS} = 0V$, $T_a = 25^\circ C$)

Parameter	Symbol	Limits	Unit
Power supply voltage	V_{DD}	- 0.3 ~ + 18	V
Power dissipation	P_d	1000 (DIP), 450 (SOP), 350 (SSOP-B14)	mW
Operating temperature	T_{opr}	- 40 ~ + 85	$^\circ C$
Storage temperature	T_{stg}	- 55 ~ + 150	$^\circ C$
Input voltage	V_{IN}	- 0.3 ~ $V_{DD} + 0.3$	V

●Electrical characteristics

DC characteristics (unless otherwise noted, $V_{SS} = 0V$, $T_a = 25^\circ C$)

Parameter	Symbol	Min.	Typ.	Max.	Unit	V _{DD} (V)	Conditions	Measurement circuit
Input high level voltage	V _{IH}	4.0	—	—	V	5	—	Fig.1
		8.0	—	—		10		
		12.5	—	—		15		
Input low level voltage	V _{IL}	—	—	1.0	V	5	—	Fig.1
		—	—	2.0		10		
		—	—	2.5		15		
Input high level current	I _{IH}	—	—	0.3	μA	15	V _{IH} = 15V	Fig.1
Input low level current	I _{IL}	—	—	-0.3	μA	15	V _{IL} = 0V	Fig.1
Output high level voltage	V _{OH}	4.95	—	—	V	5	I _o = 0mA	Fig.1
		9.95	—	—		10		
		14.95	—	—		15		
Output low level voltage	V _{OL}	—	—	0.05	V	5	I _o = 0mA	Fig.1
		—	—	0.05		10		
		—	—	0.05		15		
Output high level current	I _{OH}	-0.16	—	—	mA	5	V _{OH} = 4.6V	Fig.1
		-0.4	—	—		10	V _{OH} = 9.5V	
		-1.2	—	—		15	V _{OH} = 13.5V	
Output low level current	I _{OL}	0.44	—	—	mA	5	V _{OL} = 0.4V	Fig.1
		1.1	—	—		10	V _{OL} = 0.5V	
		3.0	—	—		15	V _{OL} = 1.5V	
Static current dissipation	I _{DD}	—	—	1	μA	5	V _i = V _{DD} or GND	—
		—	—	2		10		
		—	—	4		15		

Switching characteristics (unless otherwise noted, Ta = 25°C, Vss = 0V, CL = 50pF)

Parameter	Symbol	Min.	Typ.	Max.	Unit	V _{DD} (V)	Conditions	Measurement circuit
						5		
Output rise time	t _{TLH}	—	180	—	ns	5	—	Fig.2
		—	90	—		10		
		—	65	—		15		
Output fall time	t _{THL}	—	100	—	ns	5	—	Fig.2
		—	50	—		10		
		—	40	—		15		
“L” to “H” Propagation delay time	t _{PLH}	—	90	—	ns	5	—	Fig.2
		—	50	—		10		
		—	40	—		15		
“H” to “L” Propagation delay time	t _{PHL}	—	65	—	ns	5	—	Fig.2
		—	40	—		10		
		—	30	—		15		
Input capacitance	C _{IN}	—	5	—	pF	—	—	—

● Measurement circuits

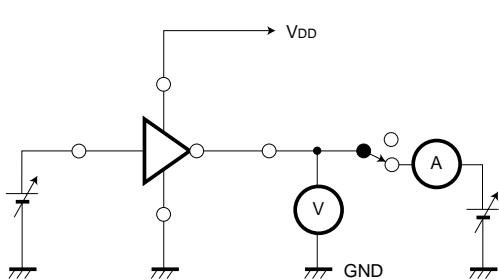

Fig. 1 DC characteristics

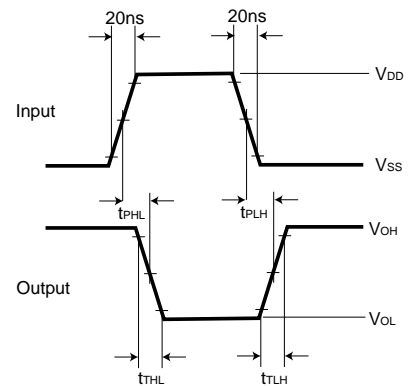
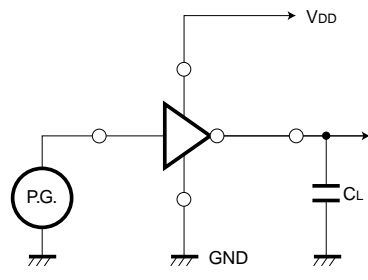

Fig. 2 Switching characteristics

●Electrical characteristic curve

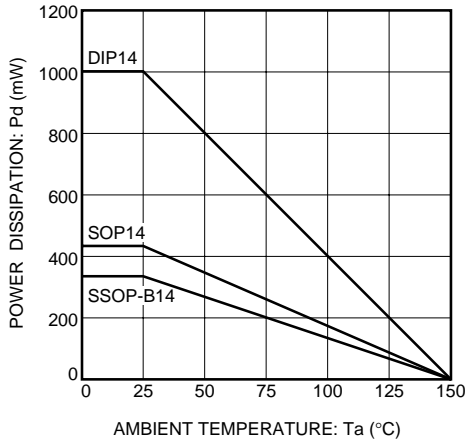

Fig. 3 Power dissipation vs. Ta

●External dimensions (Units: mm)

