

**ALD6 Dimmer Enclosure
(cover off)**

FEATURES

- Attractive crinkle black finish.
- Available in 2 sizes: ALD6 (6 dimmer capacity) and ALD12 (12 dimmer capacity).
- An enclosure consists of:
 - Steel box and cover
 - Neutral and input terminations
 - Mounting rails for dimmer modules
 - Power supply for controls
 - Cooling fan for dimmers

APPLICATIONS

- The enclosure is supplied as a pre-assembled unit with the dimmer modules and dimmer electronics pre-installed and wired.
- The dimmer panel also serves as the distribution panel. No branch circuit breaker panel is required.
- The input circuiting to the dimmer modules is connected and balanced at the factory according to the load information supplied by the customer.
- The appropriate dimmer control electronic components are installed and connected. Input terminals for control stations are also pre-installed and connected. Changes to the internal circuiting can be field modified.
- The assembled dimmer panel (enclosure, dimmer modules and control electronics) receives a full power test prior to shipment.

CERTIFICATIONS

- UL Listed (File #E107476)
- CSA (Canadian Standards File #LR39552-13)

Part Number	Dimmer Capacity	Input Feed
ALD-6-1	6 ALD Dimmer Modules	100A 3 Phase/4 Wire
ALD-6-1	6 ALD Dimmer Modules	150A 1 Phase/3 Wire
ALD-12	12 ALD Dimmer Modules	200A 3 Phase/4Wire

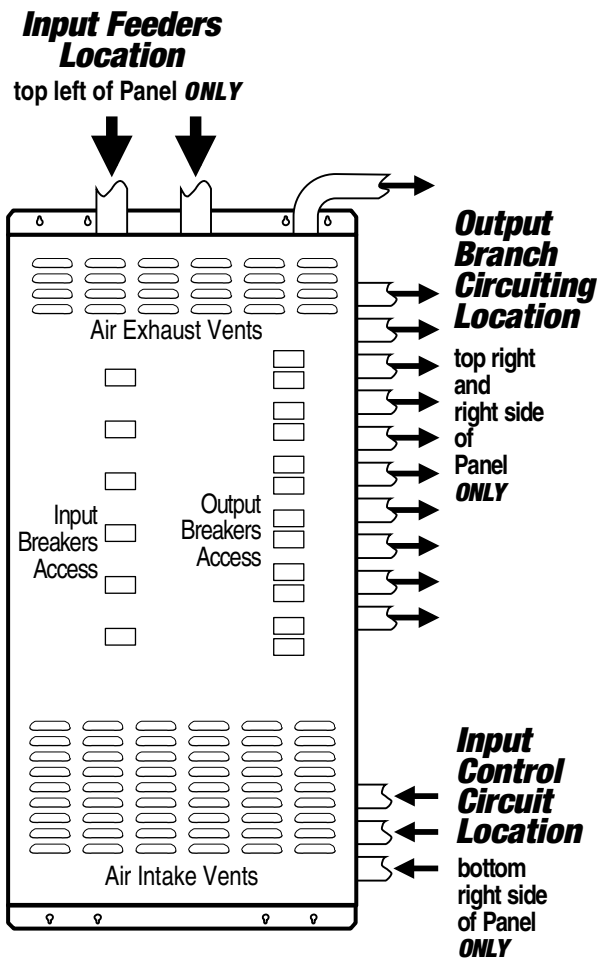

**ALD Dimmer Panel
(cover installed)**

INSTALLATION

- The Dimmer Panel must be mounted in the orientation shown in the illustration at left.
- Note the *location* of the input feeder(s), output branch circuiting and input control circuits from the wall stations. (Consult '*Dimensions -ALD6 Enclosure*' and '*Dimensions -ALD12 Enclosure*' on the following 2 pages to assist with correct location of conduits.)
- Install the mounting fasteners:
 - Mounting fasteners are not supplied.
 - Use a fastener that has a 1/4" shank.
 - Install upper 2 fasteners first, use key holes in cabinet flange to hang. Tighten fasteners, then install lower 2 fasteners.
- Install conduit and pull wires.
- The installer is responsible for wiring and connecting the input supply and output circuits to the fixture and the wires from the control stations to the panel.

SITE REQUIREMENTS

- The panel location must have ventilation.
- The panel location must be free of excess dust.
- The ambient temperature must be between 30° F (0° C) and 110° F (40° C).
- The mounting wall must be vibration-free.
- The atmosphere in the room must be non-corrosive.
- The humidity in the room must be non-condensing.

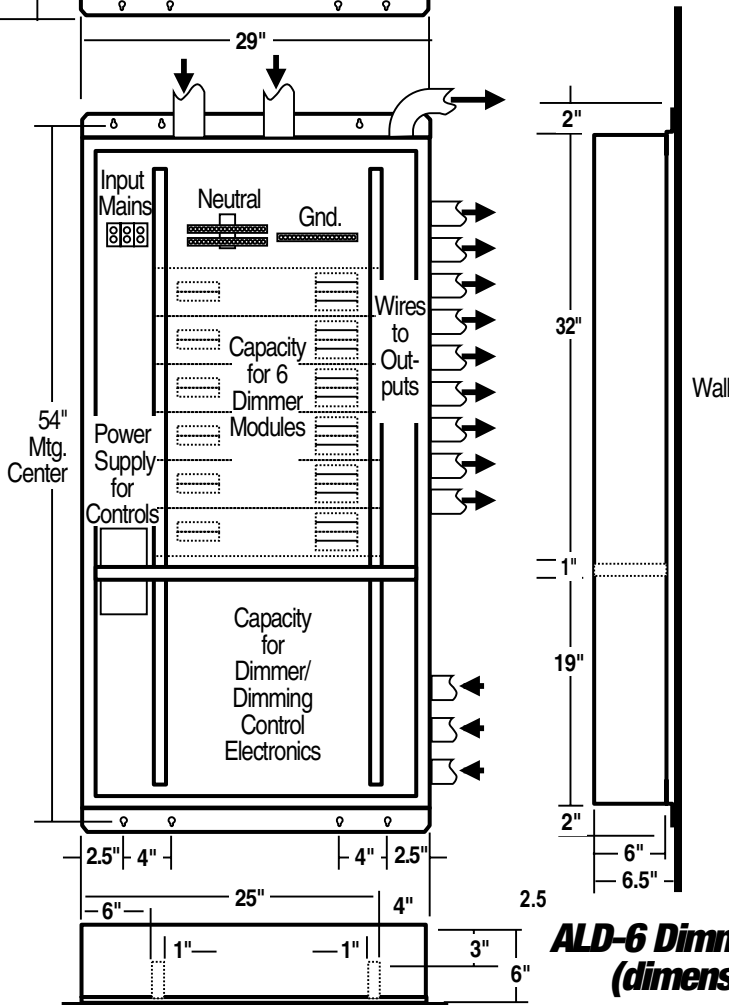
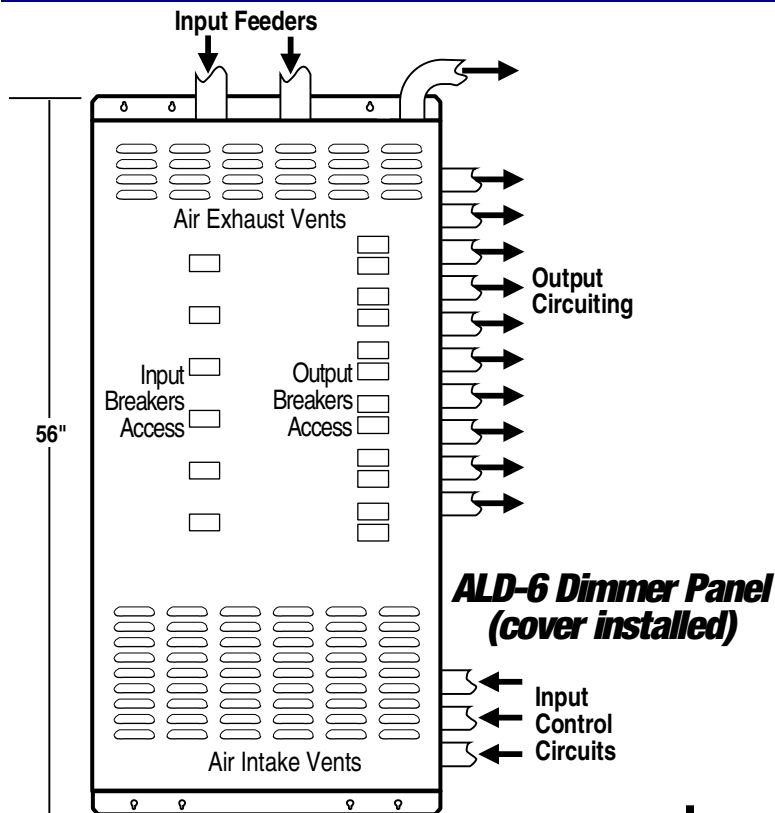

INSTALLATION NOTES

- Check local electrical codes for wire size. Terminal sizes supplied in panel will accept the following AWG sizes:
 - Input Mains: #0 per phase, #8 for neutral, #6 for GND
 - Output Breakers: #12 per branch circuit
 - Neutral Bar: 24 terminals, two #12 per terminal
 - Ground Bar: 24 terminals, two #12 per terminal
- ALD-6 Dimmer Panel is a 3 phase/4 wire panel. 100A per phase is the design size for the input feeder.
- IMPORTANT: Be sure to install conduits at locations shown. The internal construction of the panel does not permit entry of conduits at other locations.

SPECIFICATIONS

- UL Listed and CSA Certified.
 - Baked Epoxy Finish: Crinkle Black.
 - Material of Cabinet: 14 Gauge Steel.
 - Weight of empty Cabinet: 80 lbs (36 kg).
- NOTE: The weight of a panel with installed dimmer modules and control electronics is approximately 160 lbs (72 kg).

INSTALLATION NOTES

- Check local electrical codes for wire size. Terminal sizes supplied in panel will accept the following AWG sizes:
 - Input Mains: #000 per phase, #8 for neutral, #4 for GND
 - Output Breakers: #12 per branch circuit
 - Neutral Bar: 48 terminals, two #12 per terminal
 - Ground Bar: 48 terminals, two #12 per terminal
- ALD-12 Dimmer Panel is a 3 phase/4 wire panel. 200A per phase is the design size for the input feeder.
- IMPORTANT: Be sure to install conduits at locations shown. The internal construction of the panel does not permit entry of conduits at other locations.

SPECIFICATIONS

- UL Listed and CSA Certified.
 - Baked Epoxy Finish: Crinkle Black.
 - Material of Cabinet: 14 Gauge Steel.
 - Weight of empty Cabinet: 170 lbs (78 kg).
- NOTE: The weight of a panel with installed dimmer modules and control electronics is approximately 330 lbs (150 kg).

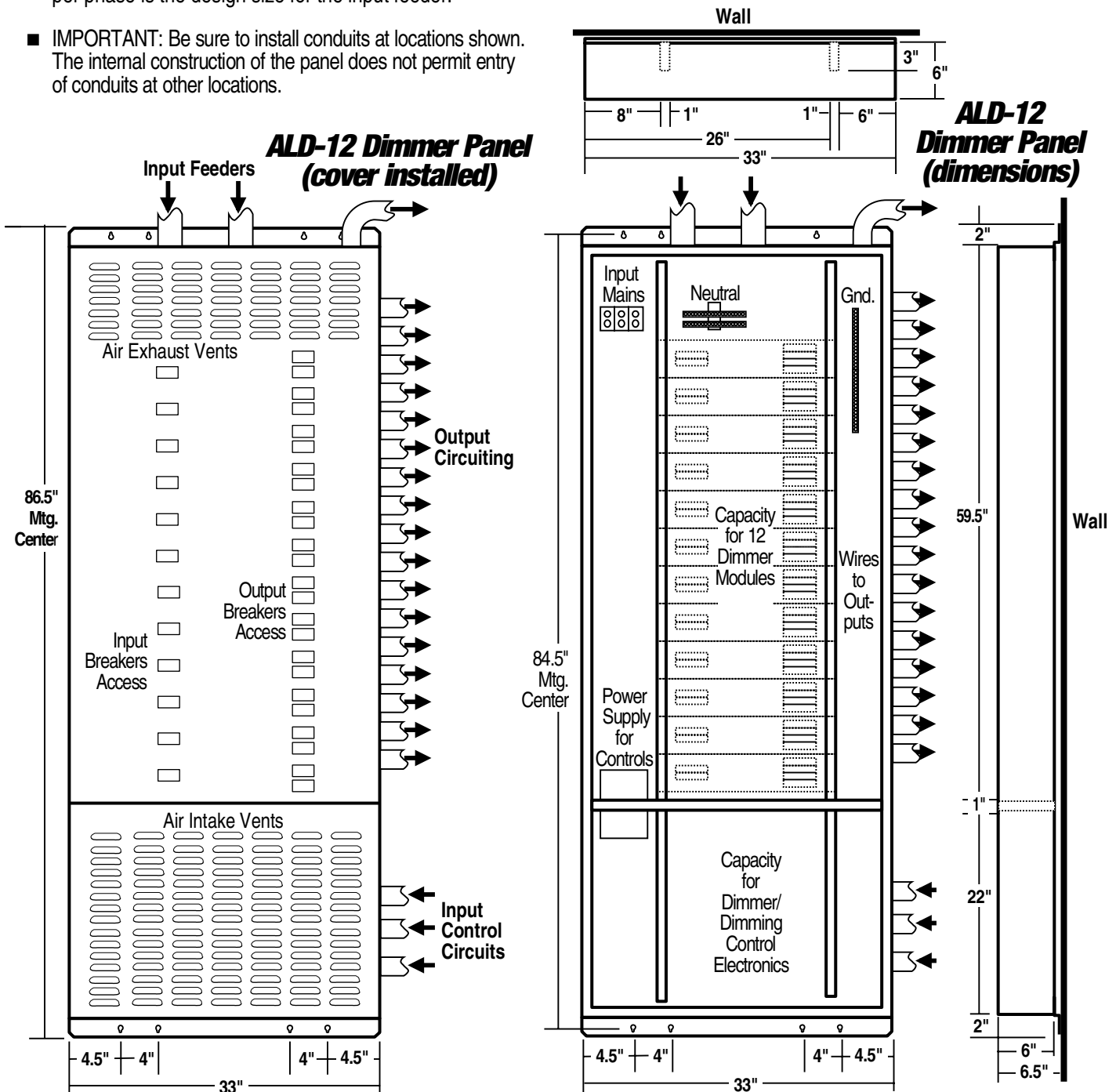

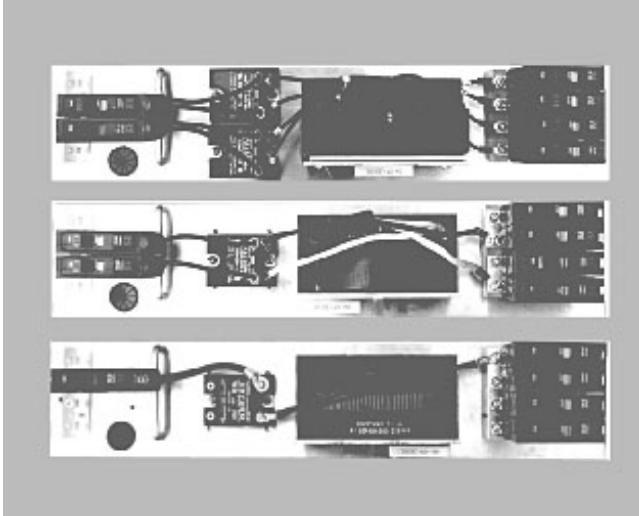
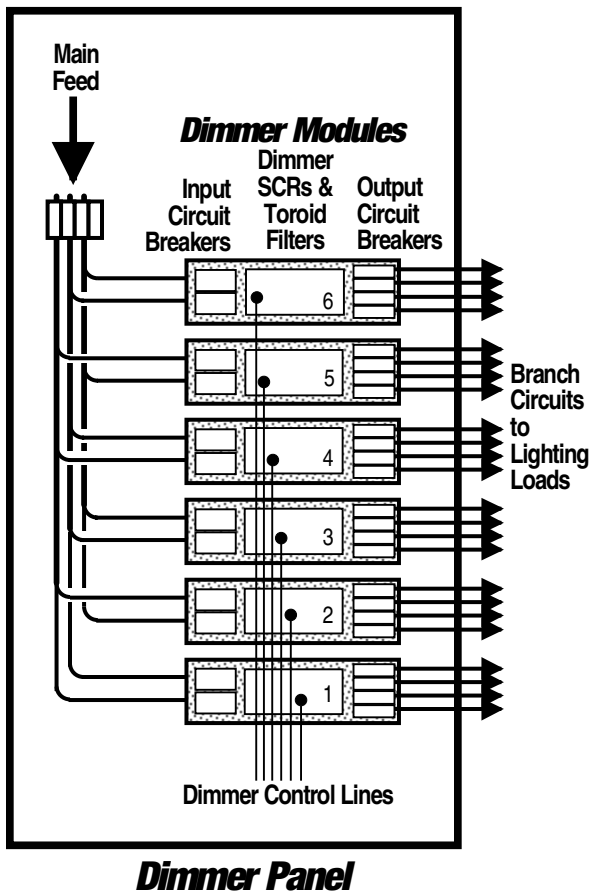
**ALD Dimmer Modules****FEATURES**

- Modular, panel mount design to suit ADL enclosures.
- Size range includes 1.2 kw, 2.4 kw and 6.0 kw dimmers.
- Capability of multiple output breakers to service several similar loads.
- High-performance SCR technology with toroidal filtering to ensure reliable, smooth dimming.
- Suitability for all types of incandescent loads, including low-voltage halogen (MR-16), quartz, neon and cold cathode lamps.
- Smooth dimming of incandescent loads from 0% to 100%. The dimmers deliver a modified IES curve that is slightly flattened at the low end to provide an expanded dimming range for low light levels.

APPLICATIONS

- ALD Dimmer Modules are designed to dim electrical branch lighting circuits as specified by electrical codes.
- ALD Dimmer Modules are constructed so that the electrical distribution for branch circuits is done directly by the dimmer panel/module combination. No additional distribution panel is required.
- Each dimmer module is constructed with input and output circuit breakers. The main feed for the panel (typically a 3 phase/4 wire supply) is bussed to the input circuit breakers of the dimmer modules. These breakers supply and protect the dimmer. The output of the dimmer is connected to the output circuit breakers which supply and protect the load.
- Each lighting load can be connected to a separate dimmer or several lighting circuits can be connected to one large common dimmer.
- The control of the ALD Dimmer is done with a control line from the dimmer control electronics. (Control electronics are not shown in the diagram.)
- ALD Dimmer Modules rack mount into ALD dimmer enclosures. The ALD-6 Panel can house up to 6 modules and the ALD-12 Module can house up to 12 modules. The cover of the ALD Panels permits convenient access to the input and output breaker handles.

CERTIFICATIONS

- UL Listed (File #E107476)
- CSA (Canadian Standards File #LR39552-13)

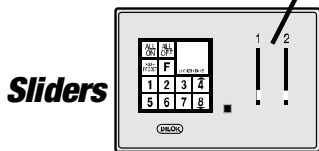
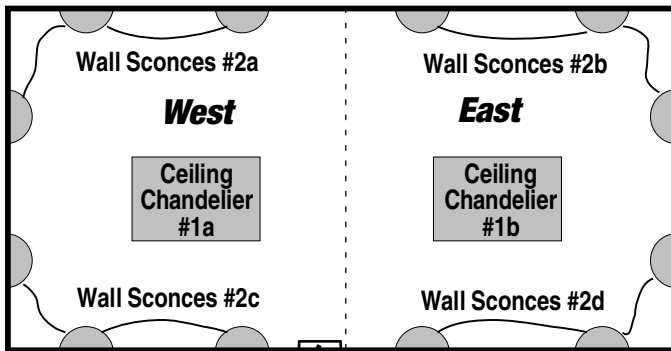

Meeting Room Application

EXAMPLE

- ALD Dimmer Modules are designed for controlling standard branch circuits. There are several options available when circuiting dimmer modules.
- In many applications each slider controls a certain type of lighting. For the meeting room example, one slider for the chandeliers and one slider for all the wall sconces. In many cases, several circuits could be controlled by one slider.
- To control multiple circuits with 1 slider (1 channel of control) there are 2 methods:
 1. Electronically patch several dimmers to dim as a group, then connect 1 branch circuit to each dimmer.
 2. Control 1 large dimmer, then connect several branch circuit breakers to that dimmer.

Method #1 is necessary in situations where the assignments of the sliders need to change (eg, dividable rooms). However, in situations where the slider assignments do not need to change, Method #2 is preferable. It is simpler to wire, simpler to program and less costly than Method #1.

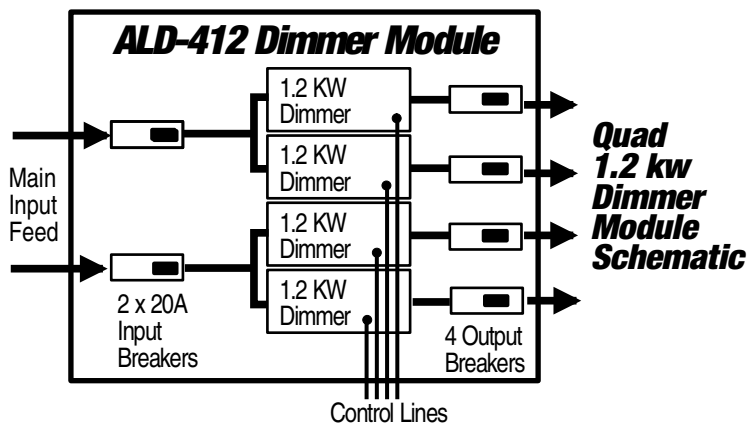
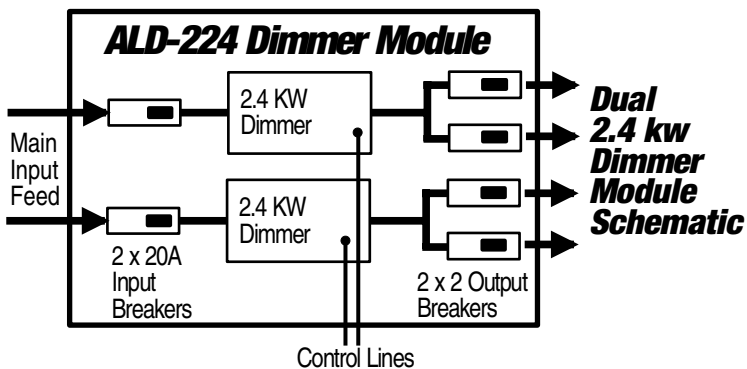
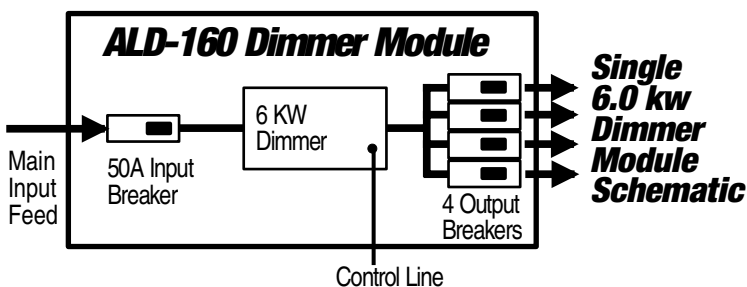

- The main cost consideration in a dimmer module is the number of dimmer the module has. Thus, a large single 6.0 kw dimmer is less expensive than a quad 1.2 kw dimmer module. Rated wattage of the dimmer has less cost impact than the number of dimmers per module.
- There are 3 ALD Dimmer Modules available. All of them deliver identical performance curves. Therefore, they can be combined in any manner suited to the application.
- For the meeting room application shown, the least costly method would be to use two ALD-160 Dimmers. The first ALD-160 would supply the 2 ceiling chandelier circuits and the second ALD-160 would supply the 4 wall sconce circuits.
- If the room needed to be divided in half on occasion, then two ALD-224 Dimmers would be required.
 - The first ALD-224 Dimmer Module would dedicate one dimmer to one chandelier circuit and one dimmer to the other chandelier circuit.
 - The second ALD-224 Dimmer Module would dedicate one dimmer to control the 2 west wall sconce circuits and the other dimmer to the 2 east wall sconce circuits.
 - The dimmers of each ALD-224 Dimmer Module would be electronically patched together when the room is open and would be individually controlled when the room is divided.

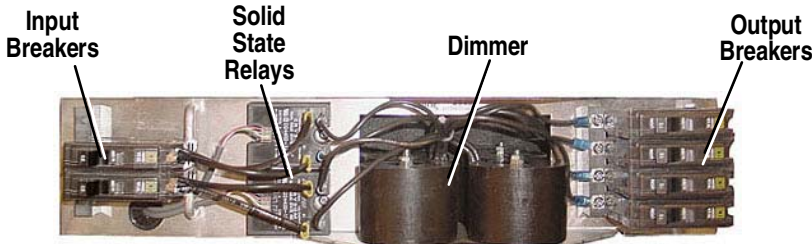

ADL Dimmer Module (typ)

Dimmer Module Part Number	Input Breakers	Quantity & Size of Dimmers	Output Breaker Capacity
ALD-160	1 x 50A: 120V	1 x 6.0 KW Dimmer	Four 15A or 20A Breakers, all bussed to same Dimmer
ALD-224	2 x 20A: 120V	2 x 2.4 KW Dimmers	Four 15A or 20A Breakers, 2 bussed to each Dimmer
ALD-412	2 x 20A: 120V	4 x 1.2 KW Dimmers	Four 15A or 20A Breakers, 1 bussed to each Dimmer
ALD-160-ND	1 x 50A: 120V	Non-Dim Module: ON/OFF only Solid State Relay: 6.0 KW size	Four 15A or 20A Breakers, all bussed to each Solid State Relay
ALD-224-ND	2 x 50A: 120V	Non-Dim Module: ON/OFF only Solid State Relay: 2 x 2.4 KW size	Four 15A or 20A Breakers, 2 bussed to each Solid State Relay
ALD-412-ND	2 x 20A: 120V	Non-Dim Module: ON/OFF only Solid State Relay: 4 x 1.2 KW size	Four 15A or 20A Breakers, 1 bussed to each Solid State Relay

Output Circuit Breaker Part Number	Breaker Capacity & Type
ALD-BRK-15	15A:120V Thermal/Magnetic
ALD-BRK-20	20A:120V Thermal/Magnetic

CONSTRUCTION

- ALD Dimmer Modules are supplied as a complete unit. Each module uses an aluminum frame plate to hold all of the circuit breakers, dimmers and the heat sinks. The frame plate is designed to mount onto the mounting rails that are a part of the ALD Dimmer Enclosure.
- All factory orders are supplied fully assembled and subjected to a full power test procedure.

ELECTRICAL SIZING

- The total power drawn by the output circuits of a dimmer cannot exceed the rating of the dimmer. Dilor dimmers can be operated at rated load.
- ALD Dimmer Modules are supplied as a complete unit. The only variation is the number of output breakers installed. Standard Square D thermal/magnetic breakers are used, and adding breakers is easy.
- The size of the output breakers can be either 15A or 20A / 120V
- The ALD-412 Dimmer is a special case. There are 4 dimmers supplied with this unit, and each is typically referred to as a 1.2 kw dimmer. However, in actual fact each is a 2.4 kw dimmer. Two of the dimmers share one input breaker and the other two dimmers share the other output breaker. The total load on either dimmer pair cannot exceed 2.4 kw. Thus, it is possible to have one "1.2 kw" dimmer with a 2.0 kw load and the other with a 0.4 kw load. Dimmers A & B are paired together and Dimmers C & D are paired together.

- ALD Dimmer Modules are high-performance products designed to provide reliable and consistent operation.
- ALD Dimmer Modules can control all types of incandescent loads including low voltage, halogen, neon and cold cathode lamps.
- Optional configurations for Dilor Dimming Systems include ON/OFF non-dim modules and electronic fluorescent dimming ballast control.

INCANDESCENT DIMMING

- ALD Dimmer Modules have matched performance curves that ensure lighting levels will be the same even when the several dimmers control one group of lights.
- ALD Dimmers deliver a modified IES curve that is flatter at the low end. This flatter low end provides more adjustment range when dimming lights at low levels.
- ALD Dimmers use SCR technology to dim the lighting circuit. SCR's are superior to other technologies as they are very difficult to false trigger. As a result, lamps dim evenly and without flicker.
- The control electronics governing the dimmer are made from high-performance components that monitor the input feed and precisely govern the SCR's synchronization with the input feed's waveform.
- Toroidal chokes are used in the dimmers to ensure a smooth AC waveform that causes no lamp hum.

LOW VOLTAGE DIMMING

- Low voltage lamps (MR-16's, etc.) use wire-wound or electronic transformers that demand a low 'DC offset'. If the AC waveform is not symmetrical or centered, a DC offset may result that will cause the low voltage transformers to buzz and possibly overheat.
- ALD Dimmer Modules and their electronic controls are designed to provide a smooth, symmetrical AC waveform with a very low 'DC offset'. ALD Dimmer Modules also use large toroidal filters that have relatively stable rise times regardless of load. This reduces the possibility of transformer and lamp hum at light loads.

COLD CATHODE DIMMING

- Cold cathode lamps use transformers that can be either LPF (Low Power Factor) capacitor-corrected or HPF (High Power Factor) no capacitor correction.
- You should always use a HPF-type transformer in dimmed cold cathode applications. Capacitors in LPF systems will cause the SCR timing circuit to produce unpredictable results.

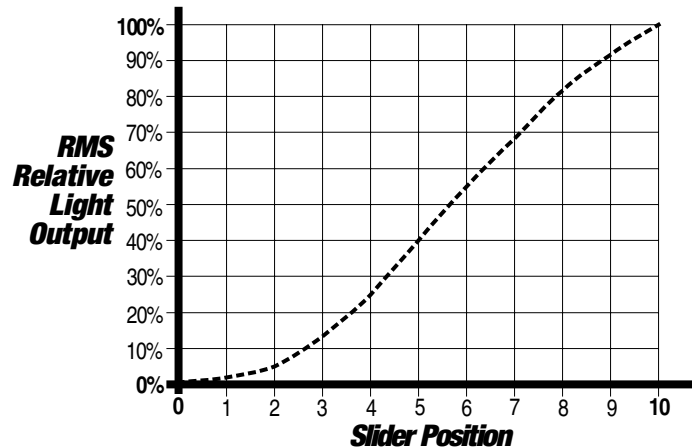

Incandescent Dimming Curve of ALD Dimmers

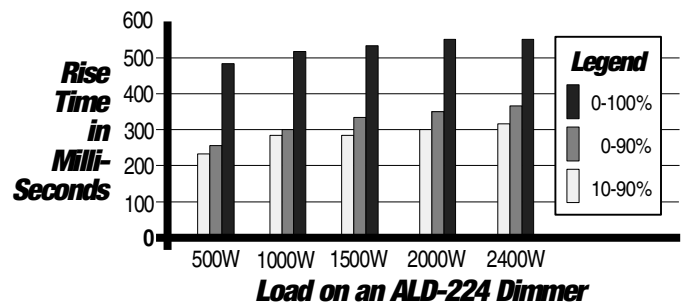

ALD Dimmer Rise Time to various Standard Values

NON-DIM CIRCUITS

- There are many instances where a circuit will not require dimming but will be regulated by the same controls used for the incandescent dimmer circuits. A typical example is ON/OFF fluorescent cove lighting.
- These types applications that require ON/OFF control only can utilize ALD-ND Non-dim Modules. They turn ON when the slider is above 50% and OFF when the slider is below 50%. ON/OFF can be included in presets in Dilor ALC3 Control Stations.

FLOURESCENT CIRCUITS

- There are applications where fluorescent lights are to be dimmed by the same control circuits used for dimming incandescent lamps. A typical example is dimmed fluorescent cove lighting.
- In most applications, 0-10v electronic dimming ballasts are the most practical solution. A Ballast Control Module, which will regulate the dimming ballasts directly, can be included with the Dimming Control Electronics. This allows dimming control of the fluorescent lights from the wall sliders or preset controls.