

BD130

NPN SILICON TRANSISTOR POWER LINERAR AND SWITCHING APPLICATIONS

The BD130 is a silicon epitaxial-base NPN transistor in JEDEC TO-3 metal case. It is intended for power switching circuits, series and shunt regulators, output stages and high fidelity amplifiers.

ABSOLUTE MAXIMUM RATINGS

Symbol	Ratings	Value	Unit
V_{CEO}	Collector-Emitter Voltage	60	V
V_{CBO}	Collector-Base Voltage	100	V
V_{CEX}	Collector-Emitter Voltage $V_{BE} = -1.5$ V	100	V
I_C	Collector Current	15	A
I_B	Base Current	7	A
P_T	Power Dissipation @ $T_C = 45^\circ$	100	Watts
T_J	Junction Temperature	-55 to +200	°C
T_S	Storage Temperature		

BD130

THERMAL CHARACTERISTICS

Symbol	Ratings	Value	Unit
R_{thJ-C}	Thermal Resistance, Junction to Case	1.55	°C/W

ELECTRICAL CHARACTERISTICS

TC=25°C unless otherwise noted

Symbol	Ratings	Test Condition(s)	Min	Typ	Mx	Unit
$V_{CEO(BR)}$	Collector-Emitter Breakdown Voltage (*)	$I_C=200\text{ mA}, I_B=0$	60			V
$V_{CE(SAT)}$	Collector-Emitter Saturation Voltage (*)	$I_C=4\text{ A}, I_B=0.4\text{ A}$	-	0.5	1.1	V
I_{CEX}	Collector-Emitter Cutoff Current	$V_{CE}=100\text{ V}$ $V_{BE}=-1.5\text{ V}$	-	-	0.5	mA
		$V_{CE}=100\text{ V}$ $V_{BE}=-1.5\text{ V}$ $T_{CASE}=150^\circ\text{C}$	-	-	30	
I_{EBO}	Emitter-Base Cutoff Current	$V_{EB}=7\text{ V}$	-	-	5.0	mA
V_{BE}	Base-Emitter Voltage (*)	$I_C=4.0\text{ A}, V_{CE}=4.0\text{ V}$	-	0.95	1.8	V
f_T	Transition Frequency	$I_C=0.1\text{ A}, V_{CE}=4\text{ V}$		1.1		MHz

BD130

Symbol	Ratings	Test Condition(s)	Min	Typ	Mx	Unit
h_{21E}	Static Forward Current Transfer Ratio (*)	$V_{CE}=4.0\text{ V}$, $I_C=4.0\text{ A}$	20	-	70	-

(*) Pulse Width $\approx 300\ \mu\text{s}$, Duty Cycle $\angle 2.0\%$

(1) collector-Emitter voltage limited et $V_{CEci} = V$ rated by an auxiliary circuit

MECHANICAL DATA CASE TO-3

DIMENSIONS		
	mm	inches
A	25,51	1,004
B	38,93	1,53
C	30,12	1,18
D	17,25	0,68
E	10,89	0,43
G	11,62	0,46
H	8,54	0,34
L	1,55	0,6
M	19,47	0,77
N	1	0,04
P	4,06	0,16

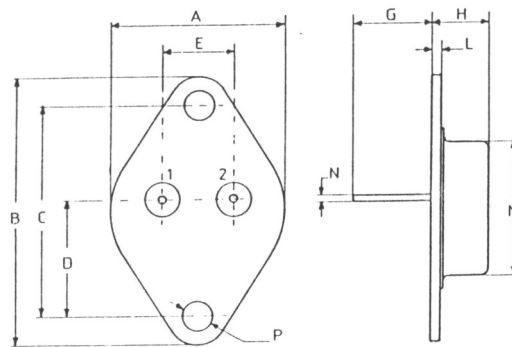

Pin 1 :	Base
Pin 2 :	Collector
Case :	Emitter