

NPN Silicon Switching Transistor

SXT 2222 A

- High current gain: 0.1 mA to 500 mA
- Low collector-emitter saturation voltage

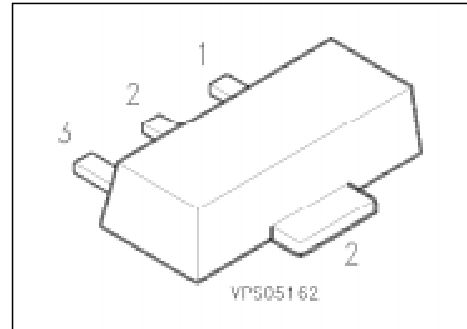

Type	Marking	Ordering Code (tape and reel)	Pin Configuration			Package ¹⁾
			1	2	3	
SXT 2222 A	2P	Q68000-A8330	B	C	E	SOT-89

Maximum Ratings

Parameter	Symbol	Values	Unit
Collector-emitter voltage	V_{CE0}	40	V
Collector-base voltage	V_{CB0}	75	
Emitter-base voltage	V_{EB0}	6	
Collector current	I_C	600	mA
Total power dissipation, $T_s = 120\text{ °C}$	P_{tot}	1	W
Junction temperature	T_j	150	°C
Storage temperature range	T_{stg}	- 65 ... + 150	

Thermal Resistance

Junction - ambient ²⁾	$R_{th\ JA}$	≤ 90	K/W
Junction - soldering point	$R_{th\ JS}$	≤ 30	

1) For detailed information see chapter Package Outlines.

2) Package mounted on epoxy pcb 40 mm × 40 mm × 1.5 mm/6 cm² Cu.

Electrical Characteristicsat $T_A = 25\text{ °C}$, unless otherwise specified.

Parameter	Symbol	Values			Unit
		min.	typ.	max.	

DC characteristics

Collector-emitter breakdown voltage $I_C = 10\text{ mA}$	$V_{(BR)CE0}$	40	–	–	V
Collector-base breakdown voltage $I_C = 10\text{ }\mu\text{A}$	$V_{(BR)CB0}$	75	–	–	
Emitter-base breakdown voltage $I_E = 10\text{ }\mu\text{A}$	$V_{(BR)EB0}$	6	–	–	
Collector-base cutoff current $V_{CB} = 60\text{ V}$, $I_E = 0$ $V_{CB} = 60\text{ V}$, $I_E = 0$, $T_A = 125\text{ °C}$	I_{CB0}	–	–	10	nA μA
Collector cutoff current $V_{CE} = 30\text{ V}$, $V_{BE} = 0.5\text{ V}$	I_{CEX}	–	–	10	nA
Emitter-base cutoff current $V_{EB} = 3\text{ V}$, $I_C = 0$	I_{EB0}	–	–	10	
Base cutoff current $V_{CE} = 30\text{ V}$, $V_{BE} = -3\text{ V}$	I_{BL}	–	–	20	
DC current gain $I_C = 100\text{ }\mu\text{A}$, $V_{CE} = 10\text{ V}$ $I_C = 1\text{ mA}$, $V_{CE} = 10\text{ V}$ $I_C = 10\text{ mA}$, $V_{CE} = 10\text{ V}$ $I_C = 10\text{ mA}$, $V_{CE} = 10\text{ V}$, $T_A = -55\text{ °C}$ $I_C = 150\text{ mA}$, $V_{CE} = 10\text{ V}$ $I_C = 150\text{ mA}$, $V_{CE} = 1\text{ V}$ $I_C = 500\text{ mA}$, $V_{CE} = 10\text{ V}$	h_{FE}	35 50 75 35 100 50 40	– – – – – – –	– – – – 300 – –	–
Collector-emitter saturation voltage ¹⁾ $I_C = 150\text{ mA}$, $I_B = 15\text{ mA}$ $I_C = 500\text{ mA}$, $I_B = 50\text{ mA}$	V_{CEsat}	– –	– –	0.3 1.0	V
Base-emitter saturation voltage ¹⁾ $I_C = 150\text{ mA}$, $I_B = 15\text{ mA}$ $I_C = 500\text{ mA}$, $I_B = 50\text{ mA}$	V_{BEsat}	0.6 –	– –	1.2 2.0	

1) Pulse test conditions: $t \leq 300\text{ }\mu\text{s}$, $D \leq 2\%$.

Electrical Characteristicsat $T_A = 25\text{ °C}$, unless otherwise specified.

Parameter	Symbol	Values			Unit
		min.	typ.	max.	

AC characteristics

Transition frequency $I_C = 50\text{ mA}$, $V_{CE} = 20\text{ V}$, $f = 100\text{ MHz}$	f_t	300	–	–	MHz
Output capacitance $V_{CB} = 10\text{ V}$, $f = 1\text{ MHz}$	C_{obo}	–	–	8	pF
Input capacitance $V_{EB} = 2\text{ V}$, $f = 1\text{ MHz}$	C_{ibo}	–	–	25	
Input impedance $I_C = 1\text{ mA}$, $V_{CE} = 10\text{ V}$, $f = 1\text{ kHz}$ $I_C = 10\text{ mA}$, $V_{CE} = 10\text{ V}$, $f = 1\text{ kHz}$	h_{ie}	2 0.25	– –	8 1.25	k Ω
Voltage feedback ratio $I_C = 1\text{ mA}$, $V_{CE} = 10\text{ V}$, $f = 1\text{ kHz}$ $I_C = 10\text{ mA}$, $V_{CE} = 10\text{ V}$, $f = 1\text{ kHz}$	h_{re}	– –	– –	8 4	10^{-4}
Small-signal current gain $I_C = 1\text{ mA}$, $V_{CE} = 10\text{ V}$, $f = 1\text{ kHz}$ $I_C = 10\text{ mA}$, $V_{CE} = 10\text{ V}$, $f = 1\text{ kHz}$	h_{fe}	50 75	– –	300 375	–
Output admittance $I_C = 1\text{ mA}$, $V_{CE} = 10\text{ V}$, $f = 1\text{ kHz}$ $I_C = 10\text{ mA}$, $V_{CE} = 10\text{ V}$, $f = 1\text{ kHz}$	h_{oe}	5 25	– –	35 200	μS
Collector-base time constant $I_E = 20\text{ mA}$, $V_{CB} = 20\text{ V}$, $f = 31.8\text{ MHz}$	$r_b' C_c$	–	–	150	ps
Noise figure $I_C = 100\text{ }\mu\text{A}$, $V_{CE} = 10\text{ V}$, $R_S = 1\text{ k}\Omega$, $f = 1\text{ kHz}$	NF	–	–	4	dB
Switching times $V_{CC} = 30\text{ V}$, $V_{BE} = 0.5\text{ V}$, $I_C = 150\text{ mA}$, $I_{B1} = 15\text{ mA}$	t_d t_r	– –	– –	10 25	ns ns
$V_{CC} = 30\text{ V}$, $I_C = 150\text{ mA}$, $I_{B1} = I_{B2} = 15\text{ mA}$	t_s t_f	– –	– –	225 60	ns ns

Test circuits

Delay and rise time

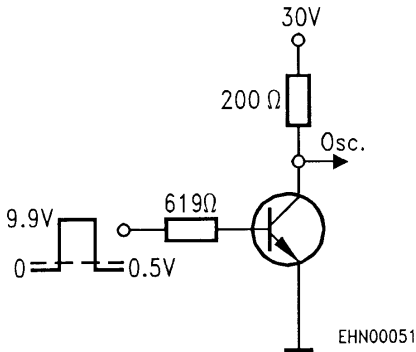

Storage and fall time

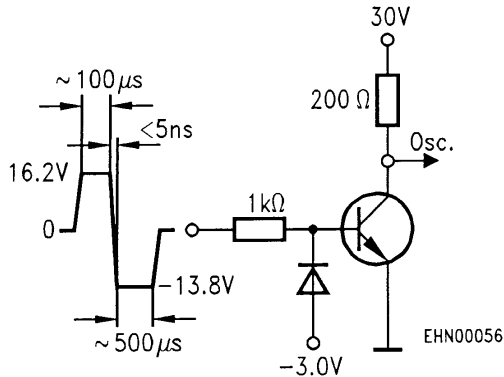

Total power dissipation $P_{tot} = f(T_A^*; T_S)$

* Package mounted on epoxy

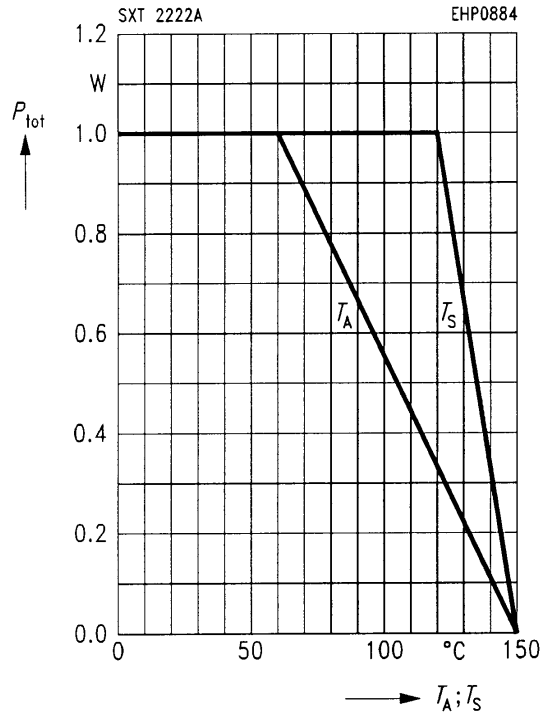

Collector-base capacitance $C_{cb} = f(V_{CB})$

$f = 1$ MHz

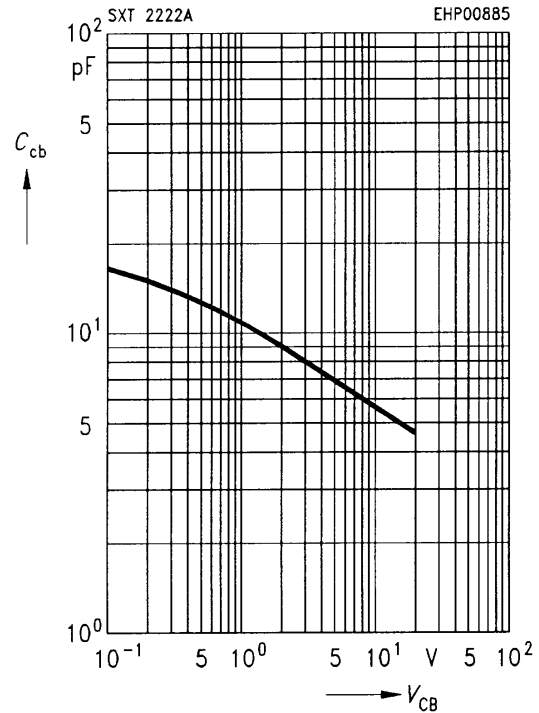

Permissible pulse load $P_{tot max} / P_{tot DC} = f(t_p)$

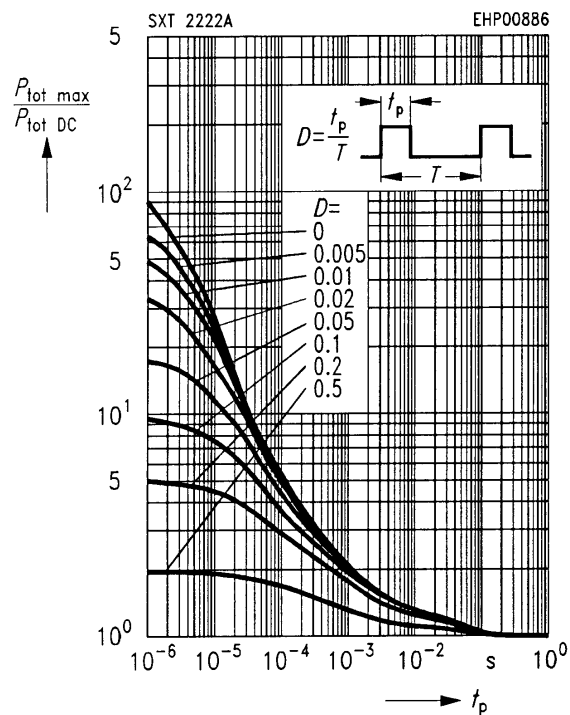

Transition frequency $f_T = f(I_C)$

$V_{CE} = 20$ V

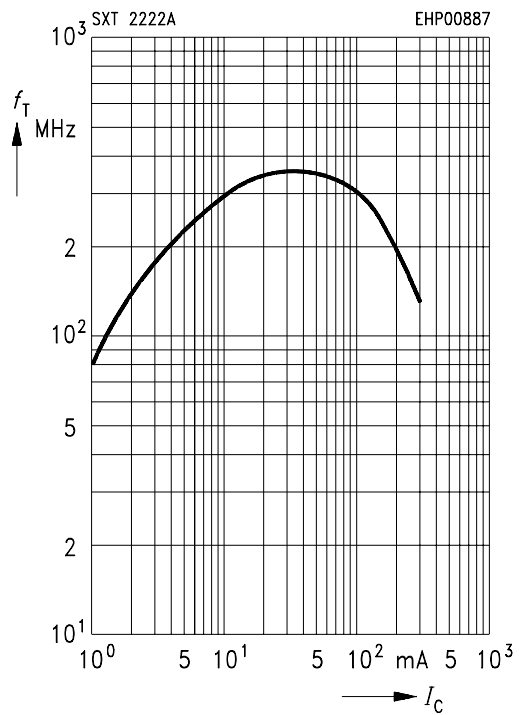

Saturation voltage $I_C = f(V_{BE\ sat}, V_{CE\ sat})$
 $h_{FE} = 10$

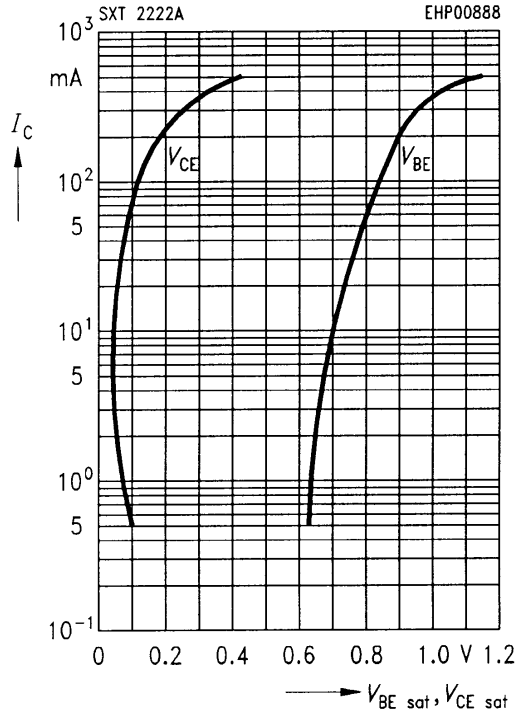

DC current gain $h_{FE} = f(I_C)$
 $V_{CE} = 10\ V$

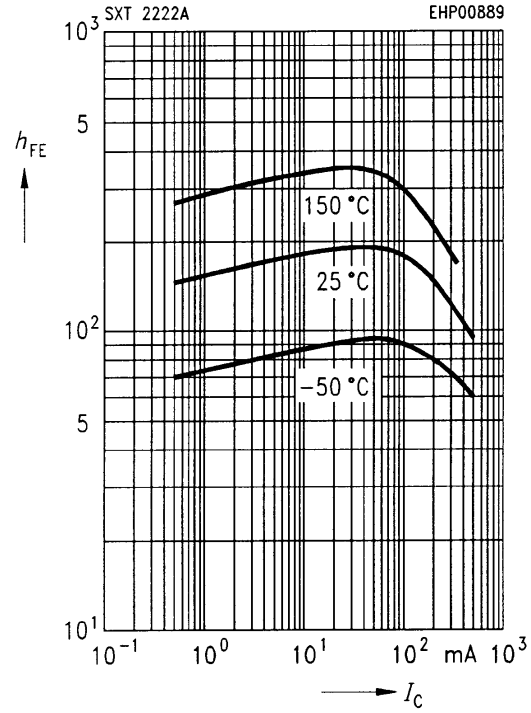

Delay time $t_d = f(I_C)$
Rise time $t_r = f(I_C)$

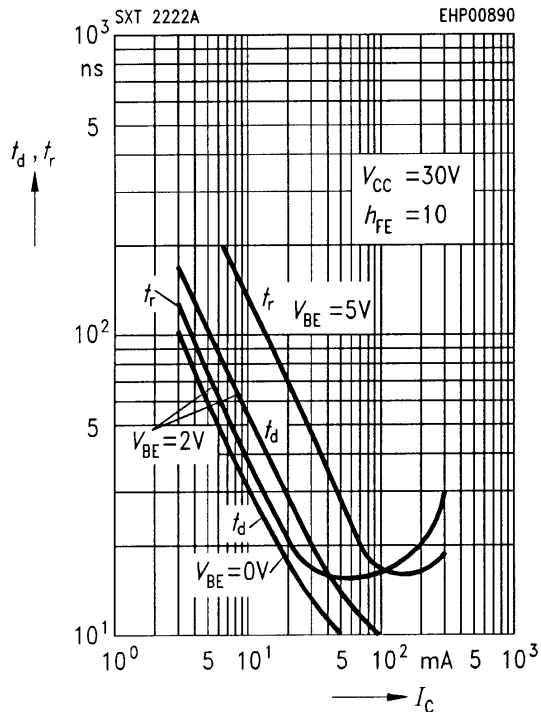

Storage time $t_s = f(I_C)$
Fall time $t_f = f(I_C)$

