

Features

- Epitaxial Planar Die Construction
- One Transistor and One Switching Diode in One Package
- **Lead Free By Design/RoHS Compliant (Note 1)**
- **"Green" Device (Note 2)**

Mechanical Data

- Case: SOT-363
- Case Material: Molded Plastic. "Green" Molding Compound. UL Flammability Classification Rating 94V-0
- Moisture sensitivity: Level 1 per J-STD-020C
- Terminal Connections: See Diagram
- Terminals: Finish - Matte Tin annealed over Alloy 42 leadframe. Solderable per MIL-STD-202, Method 208
- Marking & Type Code Information: See Last Page
- Ordering Information: See Last Page
- Weight: 0.008 grams (approx.)

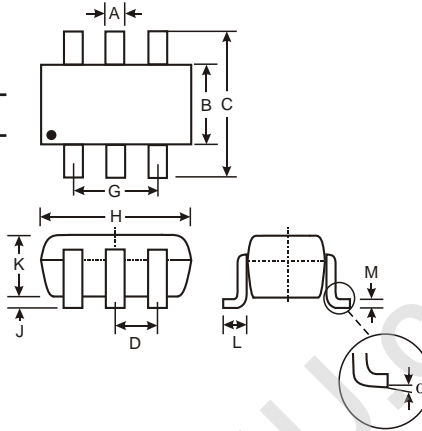

SOT-363		
Dim	Min	Max
A	0.10	0.30
B	1.15	1.35
C	2.00	2.20
D	0.65 Nominal	
F	0.30	0.40
H	1.80	2.20
J		0.10
K	0.90	1.00
L	0.25	0.40
M	0.10	0.25
	0°	8°
All Dimensions in mm		

P/N	R1 (NOM)	R2 (NOM)
DRDNB16W	1K	10K
DRDPB16W	1K	10K
DRDNB26W	220	4.7K
DRDPB26W	220	4.7K

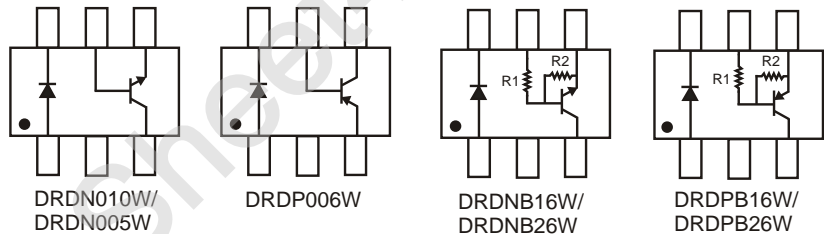

Maximum Ratings, Total Device @ T_A = 25°C unless otherwise specified

Characteristic	Symbol	Value	Unit
Power Dissipation (Note 3)	P _d	200	mW
Thermal Resistance, Junction to Ambient Air (Note 3)	R _{JA}	625	°C/W
Operating and Storage and Temperature Range	T _j , T _{STG}	-55 to +150	°C

Maximum Ratings, DRDN010W NPN Transistor @ T_A = 25°C unless otherwise specified

Characteristic	Symbol	Value	Unit
Collector-Base Voltage	V _{CB0}	45	V
Collector-Emitter Voltage	V _{CEO}	18	V
Emitter-Base Voltage	V _{EB0}	5	V
Collector Current (Note 3)	I _C	1000	mA

Maximum Ratings, DRDN005W NPN Transistor @ T_A = 25°C unless otherwise specified

Characteristic	Symbol	Value	Unit
Collector-Base Voltage	V _{CB0}	80	V
Collector-Emitter Voltage	V _{CEO}	80	V
Emitter-Base Voltage	V _{EB0}	4.0	V
Collector Current - Continuous (Note 3)	I _C	500	mA

- Notes:
1. No purposefully added lead.
 2. Diodes Inc.'s "Green" policy can be found on our website at http://www.diodes.com/products/lead_free/index.php.
 3. Device mounted on FR-4 PCB, 1 inch x 0.85 inch x 0.062 inch; pad layout as shown on Diodes Inc. suggested pad layout document AP02001, which can be found on our website at <http://www.diodes.com/datasheets/ap02001.pdf>.

Maximum Ratings, DRDP006W PNP Transistor @ $T_A = 25^\circ\text{C}$ unless otherwise specified

Characteristic	Symbol	Value	Unit
Collector-Base Voltage	V_{CBO}	-60	V
Collector-Emitter Voltage	V_{CEO}	-60	V
Emitter-Base Voltage	V_{EBO}	-5.0	V
Collector Current (Note 3)	I_C	-600	mA

Maximum Ratings, DRDNB16W Pre-Biased NPN Transistor @ $T_A = 25^\circ\text{C}$ unless otherwise specified

Characteristic	Symbol	Value	Unit
Supply Voltage	V_{CC}	50	V
Input Voltage	V_{IN}	-5 to +10	V
Output Current	I_C	600	mA

Maximum Ratings, DRDNB26W Pre-Biased NPN Transistor @ $T_A = 25^\circ\text{C}$ unless otherwise specified

Characteristic	Symbol	Value	Unit
Supply Voltage	V_{CC}	50	V
Input Voltage	V_{IN}	-5 to +5	V
Output Current	I_C	600	mA

Maximum Ratings, DRDPB16W Pre-Biased PNP Transistor @ $T_A = 25^\circ\text{C}$ unless otherwise specified

Characteristic	Symbol	Value	Unit
Supply Voltage	V_{CC}	-50	V
Input Voltage	V_{IN}	+5 to -10	V
Output Current	I_C	600	mA

Maximum Ratings, DRDPB26W Pre-Biased PNP Transistor @ $T_A = 25^\circ\text{C}$ unless otherwise specified

Characteristic	Symbol	Value	Unit
Supply Voltage	V_{CC}	-50	V
Input Voltage	V_{IN}	+5 to -5	V
Output Current	I_C	-600	mA

Maximum Ratings, Switching Diode @ $T_A = 25^\circ\text{C}$ unless otherwise specified

Characteristic	Symbol	Value	Unit
Non-Repetitive Peak Reverse Voltage	V_{RM}	100	V
Peak Repetitive Reverse Voltage Working Peak Reverse Voltage DC Blocking Voltage	V_{RRM} V_{RWM} V_R	75	V
RMS Reverse Voltage	$V_{R(RMS)}$	53	V
Forward Continuous Current (Note 3)	I_{FM}	500	mA
Average Rectified Output Current (Note 3)	I_O	250	mA
Non-Repetitive Peak Forward Surge Current @ $t = 1.0\mu\text{s}$ @ $t = 1.0\text{s}$	I_{FSM}	4.0 2.0	A

Electrical Characteristics, DRDN010W NPN Transistor @ T_A = 25°C unless otherwise specified

Characteristic	Symbol	Min	Max	Unit	Test Condition
DC Current Gain	h_{FE}	150	800		$I_C = 100\text{mA}$, $V_{CE} = 1\text{V}$
Collector-Emitter Saturation Voltage	$V_{CE(SAT)}$		0.5	V	$I_C = 300\text{mA}$, $I_B = 30\text{mA}$
Collector-Base Breakdown Voltage	$V_{(BR)CBO}$	45		V	$I_C = 100\mu\text{A}$, $I_E = 0$
Collector-Emitter Breakdown Voltage	$V_{(BR)CEO}$	18		V	$I_C = 1\text{mA}$, $I_B = 0$
Emitter-Base Breakdown Voltage	$V_{(BR)EBO}$	5		V	$I_E = 100\mu\text{A}$, $I_C = 0$
Collector Cutoff Current	I_{CBO}		1	μA	$V_{CB} = 40\text{V}$, $I_E = 0$
Emitter Cutoff Current	I_{EBO}		1	μA	$V_{EB} = 4\text{V}$, $I_C = 0$
Current Gain-Bandwidth Product	f_T	100		MHz	$V_{CE} = 10\text{V}$, $I_C = 50\text{mA}$, $f = 100\text{MHz}$
Capacitance	C_{obo}		8	pF	$V_{CB} = 10\text{V}$, $I_E = 0$, $f = 1\text{MHz}$

Electrical Characteristics, DRDN005W NPN Transistor @ T_A = 25°C unless otherwise specified

Characteristic	Symbol	Min	Max	Unit	Test Condition
Collector-Base Breakdown Voltage	$V_{(BR)CBO}$	80		V	$I_C = 100\mu\text{A}$, $I_E = 0$
Collector-Emitter Breakdown Voltage	$V_{(BR)CEO}$	80		V	$I_C = 1.0\text{mA}$, $I_B = 0$
Emitter-Base Breakdown Voltage	$V_{(BR)EBO}$	4.0		V	$I_E = 100\mu\text{A}$, $I_C = 0$
Collector Cutoff Current	I_{CBO}		100	nA	$V_{CB} = 60\text{V}$, $I_E = 0$ $V_{CB} = 80\text{V}$, $I_E = 0$
Collector Cutoff Current	I_{CES}		100	nA	$V_{CE} = 60\text{V}$, $I_{BO} = 0\text{V}$ $V_{CE} = 80\text{V}$, $I_{BO} = 0\text{V}$
DC Current Gain	h_{FE}	100			$I_C = 10\text{mA}$, $V_{CE} = 1.0\text{V}$ $I_C = 100\text{mA}$, $V_{CE} = 1.0\text{V}$
Collector-Emitter Saturation Voltage	$V_{CE(SAT)}$		0.25	V	$I_C = 100\text{mA}$, $I_B = 10\text{mA}$
Base-Emitter Saturation Voltage	$V_{BE(SAT)}$		1.2	V	$I_C = 100\text{mA}$, $V_{CE} = 1.0\text{V}$
Current Gain-Bandwidth Product	f_T	100		MHz	$V_{CE} = 2.0\text{V}$, $I_C = 10\text{mA}$, $f = 100\text{MHz}$

Electrical Characteristics, DRDP006W PNP Transistor @ T_A = 25°C unless otherwise specified

Characteristic	Symbol	Min	Max	Unit	Test Condition
DC Current Gain	h_{FE}	100	300		$I_C = -150\text{mA}$, $V_{CE} = -10\text{V}$
Collector-Emitter Saturation Voltage	$V_{CE(SAT)}$		-0.4	V	$I_C = -150\text{mA}$, $I_B = -15\text{mA}$
Collector-Base Breakdown Voltage	$V_{(BR)CBO}$	-60		V	$I_C = -10\mu\text{A}$, $I_E = 0$
Collector-Emitter Breakdown Voltage	$V_{(BR)CEO}$	-60		V	$I_C = -10\text{mA}$, $I_B = 0$
Emitter-Base Breakdown Voltage	$V_{(BR)EBO}$	-5		V	$I_E = -10\mu\text{A}$, $I_C = 0$
Collector Cutoff Current	I_{CBO}		-10	nA	$V_{CB} = -50\text{V}$, $I_E = 0$
Current Gain-Bandwidth Product	f_T	200		MHz	$V_{CE} = -20\text{V}$, $I_C = -50\text{mA}$, $f = 100\text{MHz}$
Capacitance	C_{obo}		8	pF	$V_{CB} = -10\text{V}$, $I_E = 0$, $f = 1\text{MHz}$

Electrical Characteristics, DRDNB16W Pre-Biased NPN Transistor @ T_A = 25°C unless otherwise specified

Characteristic	Symbol	Min	Typ	Max	Unit	Test Condition
Input Voltage	$V_{I(off)}$	0.3			V	$V_{CC} = 5\text{V}$, $I_O = 100\mu\text{A}$
	$V_{I(on)}$			2.0	V	$V_O = 0.3\text{V}$, $I_O = 20\text{mA}$
Output Voltage	$V_{O(on)}$			0.3V	V	$I_O/I_I = 50\text{mA}/2.5\text{mA}$
Input Current	I_I			7.2	mA	$V_I = 5\text{V}$
Output Current	$I_{O(off)}$			0.5	μA	$V_{CC} = 50\text{V}$, $V_I = 0\text{V}$
DC Current Gain	G_I	56				$V_O = 5\text{V}$, $I_O = 50\text{mA}$
Gain-Bandwidth Product	f_T		200		MHz	$V_{CE} = 10\text{V}$, $I_E = 5\text{mA}$, $f = 100\text{MHz}$

Electrical Characteristics, DRDNB26W Pre-Biased NPN Transistor @ T_A = 25°C unless otherwise specified

Characteristic	Symbol	Min	Typ	Max	Unit	Test Condition
Input Voltage	V _{I(off)}	0.5			V	V _{CC} = 5V, I _O = 100μA
	V _{I(on)}			3.0	V	V _O = 0.3V, I _O = 20mA
Output Voltage	V _{O(on)}			0.3V	V	I _O /I _I = 50mA/2.5mA
Input Current	I _I			28	mA	V _I = 5V
Output Current	I _{O(off)}			0.5	μA	V _{CC} = 50V, V _I = 0V
DC Current Gain	G _I	47				V _O = 5V, I _O = 50mA
Gain-Bandwidth Product	f _T		200		MHz	V _{CE} = 10V, I _E = 5mA, f = 100MHz

Electrical Characteristics, DRDPB16W Pre-Biased PNP Transistor @ T_A = 25°C unless otherwise specified

Characteristic	Symbol	Min	Typ	Max	Unit	Test Condition
Input Voltage	V _{I(off)}	-0.3			V	V _{CC} = -5V, I _O = -100μA
	V _{I(on)}			-2.0	V	V _O = -0.3V, I _O = -20mA
Output Voltage	V _{O(on)}			-0.3V	V	I _O /I _I = -50mA/-2.5mA
Input Current	I _I			-7.2	mA	V _I = -5V
Output Current	I _{O(off)}			-0.5	μA	V _{CC} = -50V, V _I = 0V
DC Current Gain	G _I	56				V _O = -5V, I _O = -50mA
Gain-Bandwidth Product	f _T		200		MHz	V _{CE} = -10V, I _E = -5mA, f = 100MHz

Electrical Characteristics, DRDPB26W Pre-Biased PNP Transistor @ T_A = 25°C unless otherwise specified

Characteristic	Symbol	Min	Typ	Max	Unit	Test Condition
Input Voltage	V _{I(off)}	-0.5			V	V _{CC} = -5V, I _O = -100μA
	V _{I(on)}			-3.0	V	V _O = -0.3V, I _O = -20mA
Output Voltage	V _{O(on)}			-0.3V	V	I _O /I _I = -50mA/-2.5mA
Input Current	I _I			-28	mA	V _I = -5V
Output Current	I _{O(off)}			-0.5	μA	V _{CC} = -50V, V _I = 0V
DC Current Gain	G _I	47				V _O = -5V, I _O = -50mA
Gain-Bandwidth Product	f _T		200		MHz	V _{CE} = -10V, I _E = -5mA, f = 100MHz

Electrical Characteristics, Switching Diode @ T_A = 25°C unless otherwise specified

Characteristic	Symbol	Min	Max	Unit	Test Condition
Reverse Breakdown Voltage (Note 4)	V _{(BR)R}	75			I _R = 10μA
Forward Voltage (Note 4)	V _F	0.62	0.72	V	I _F = 5.0mA
			0.855		I _F = 10mA
			1.0		I _F = 100mA
			1.25		I _F = 150mA
Reverse Current (Note 4)	I _R		2.5	μA	V _R = 75V
			50		V _R = 75V, T _J = 150°C
			30		V _R = 25V, T _J = 150°C
			25		V _R = 20V
Total Capacitance	C _T		4.0	pF	V _R = 0, f = 1.0MHz
Reverse Recovery Time	t _{rr}		4.0	ns	I _F = I _R = 10mA, I _{rr} = 0.1 x I _R , R _L = 100

Notes: 4. Short duration pulse test used to minimize self-heating effect.

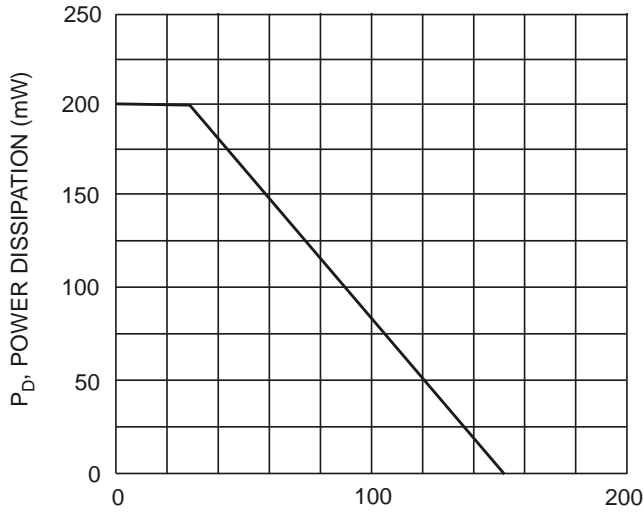

T_A , AMBIENT TEMPERATURE (°C)
Fig. 1, Power Derating Curve (Total Device)

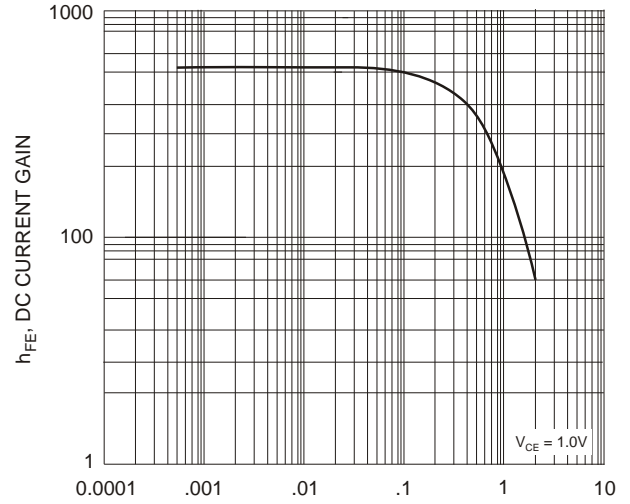

I_C , COLLECTOR CURRENT (A)
Fig. 2, Typical DC Current Gain vs. Collector Current (DRDN010W)

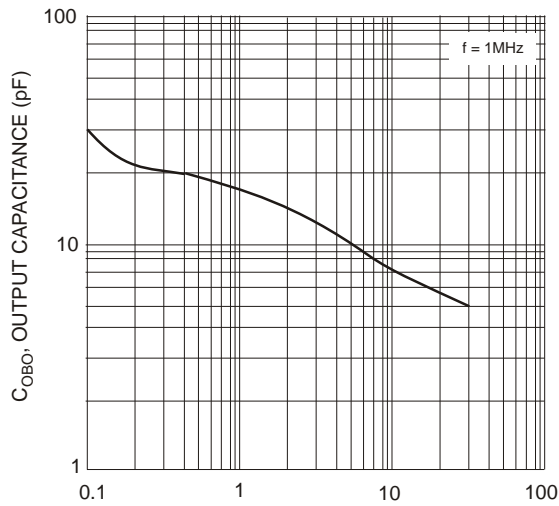

V_{CB} , COLLECTOR-BASE VOLTAGE (V)
Fig. 3, Output Capacitance vs. Collector-Base Voltage (DRDN010W)

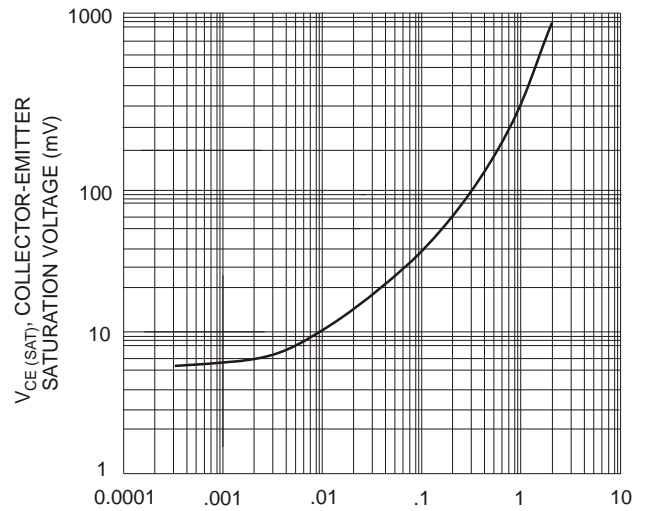

I_C , COLLECTOR CURRENT (A)
Fig. 4, Collector Saturation Voltage vs. Collector Current (DRDN010W)

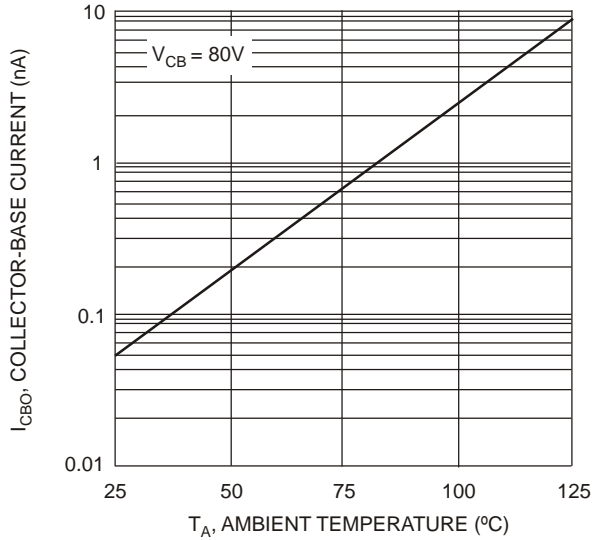

Fig. 5, Typical Collector-Cutoff Current vs. Ambient Temperature (DRDN005W)

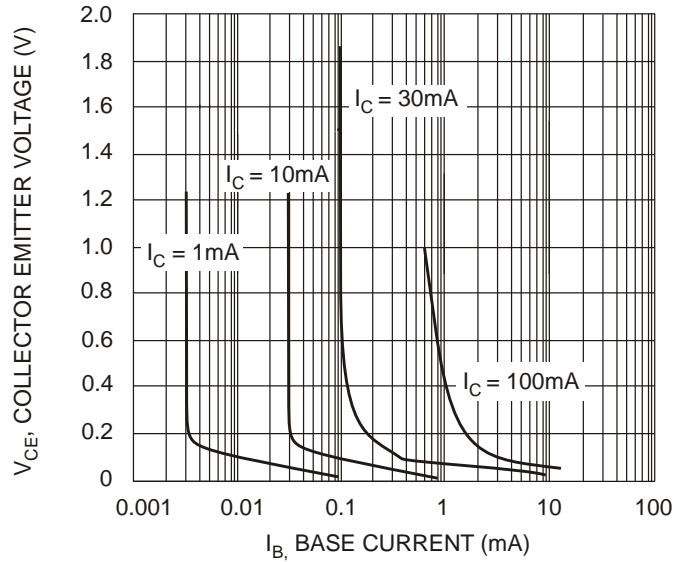

Fig. 6, Typical Collector Saturation Region (DRDN005W)

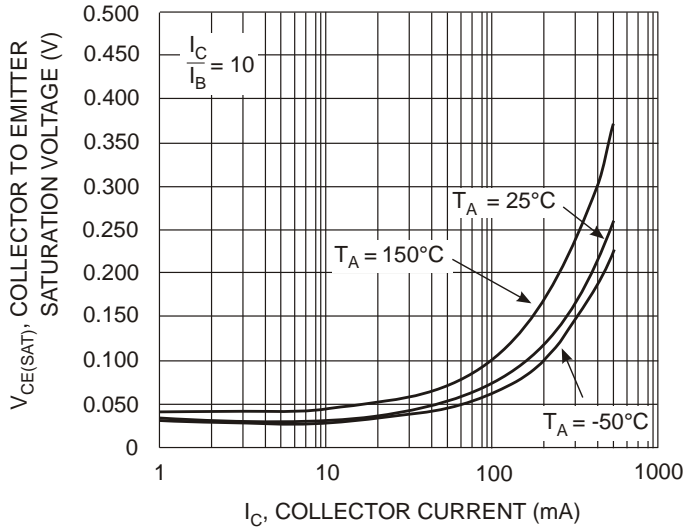

Fig. 7, Collector Emitter Saturation Voltage vs. Collector Current (DRDN005W)

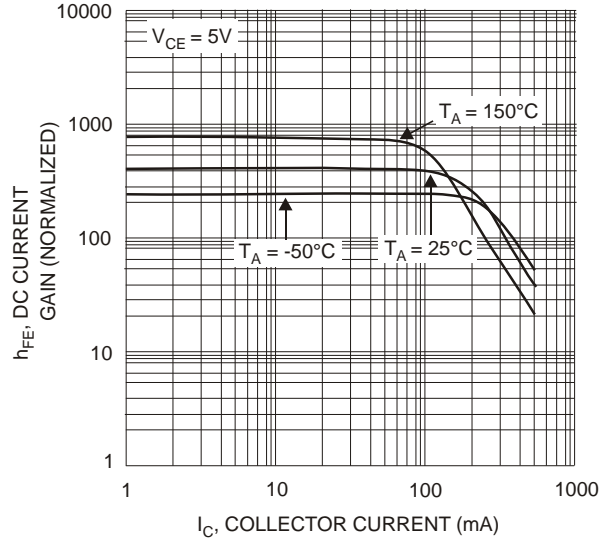

Fig. 8, DC Current Gain vs. Collector Current (DRDN005W)

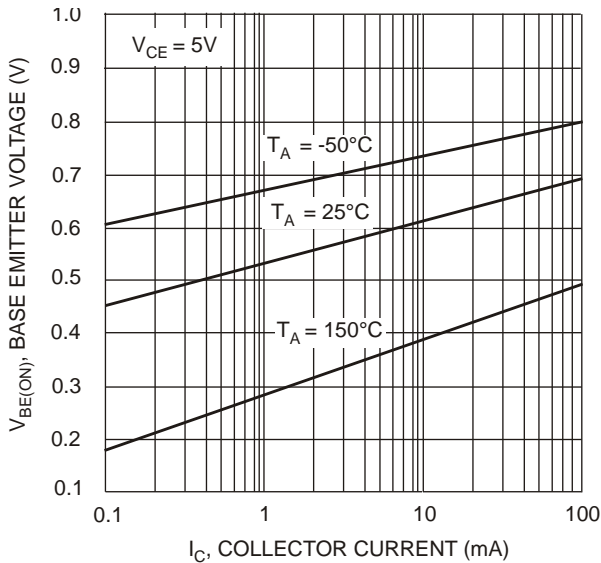

Fig. 9, Base Emitter Voltage vs. Collector Current (DRDN005W)

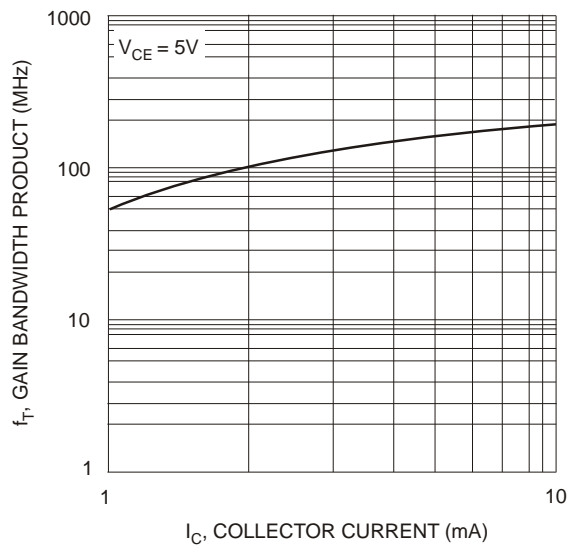
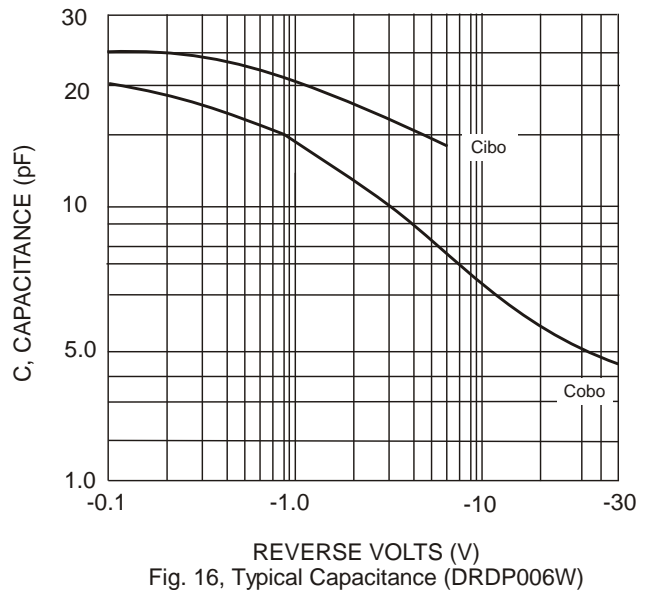
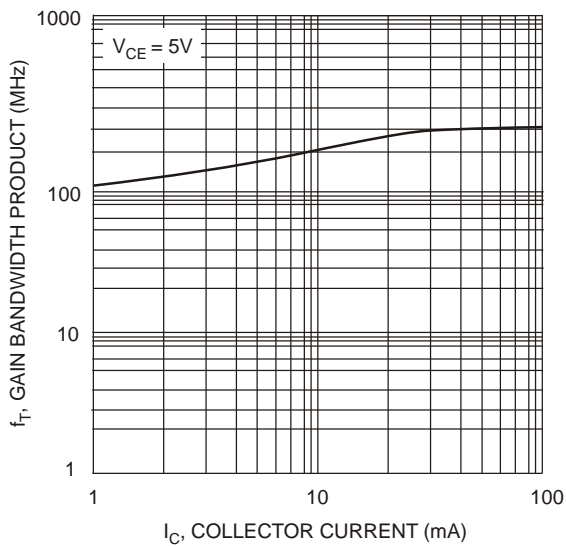
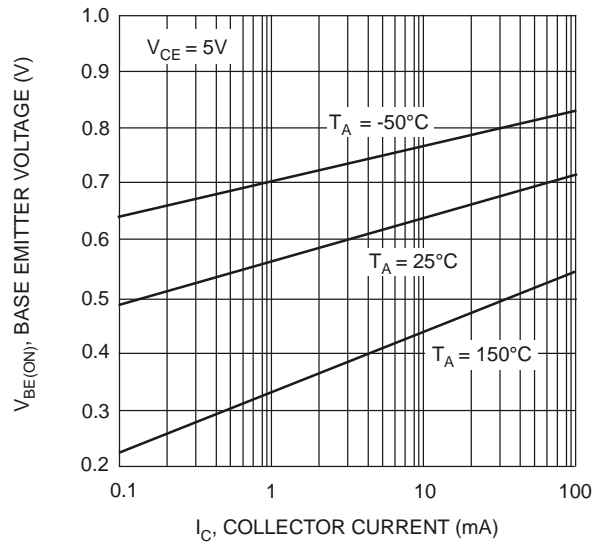
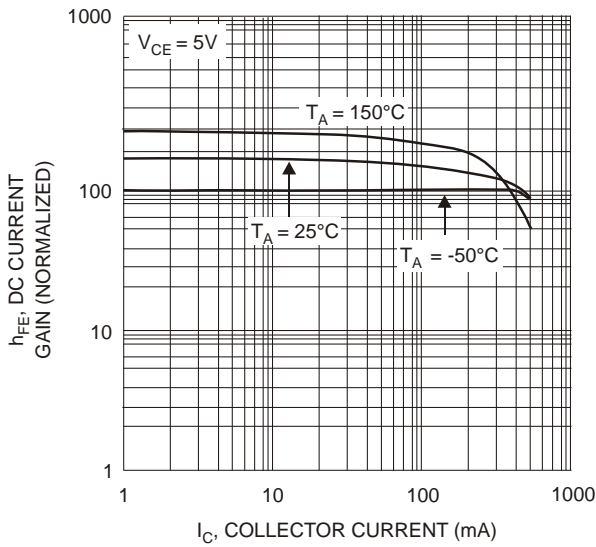
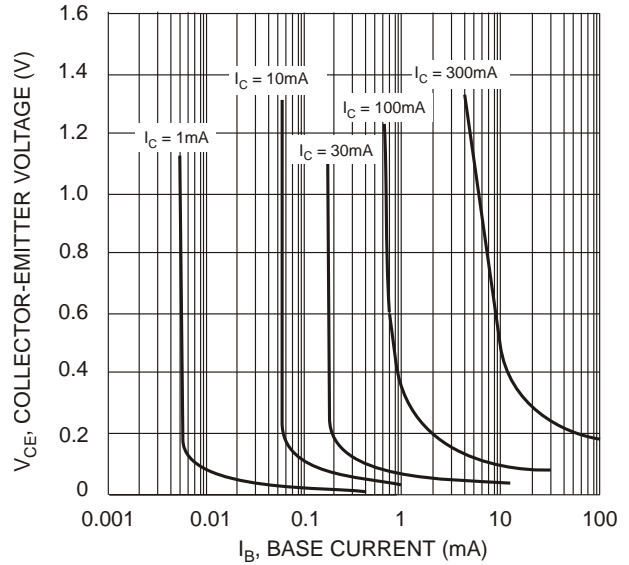
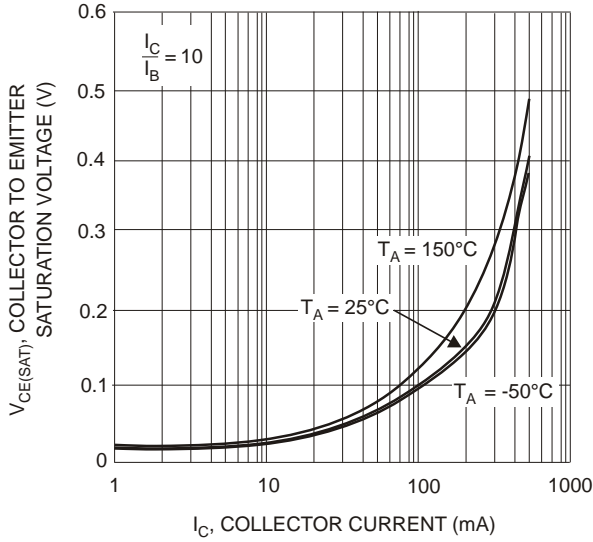

Fig. 10, Gain Bandwidth Product vs. Collector Current (DRDN005W)



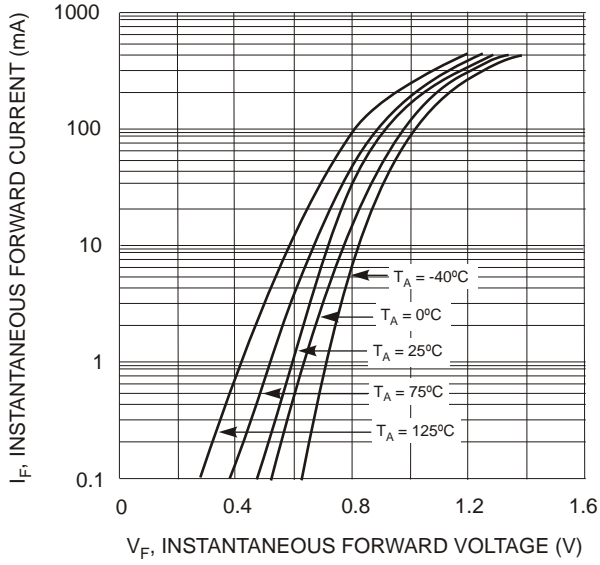

Fig. 17, Typical Forward Characteristics (Switching Diode)

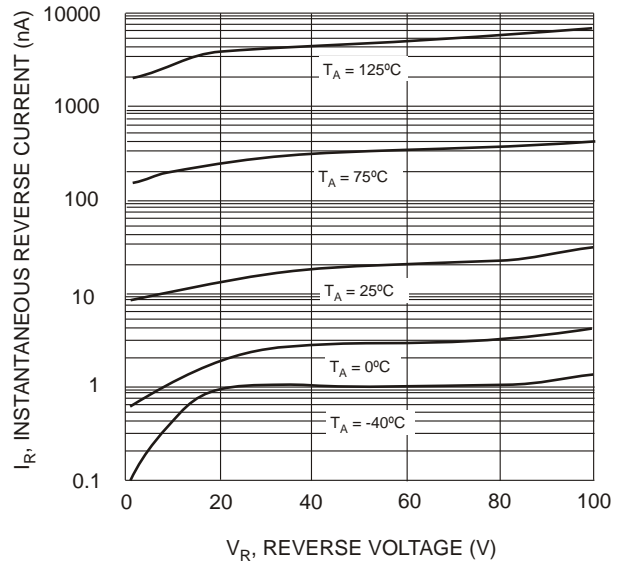

Fig. 18, Typical Reverse Characteristics (Switching Diode)

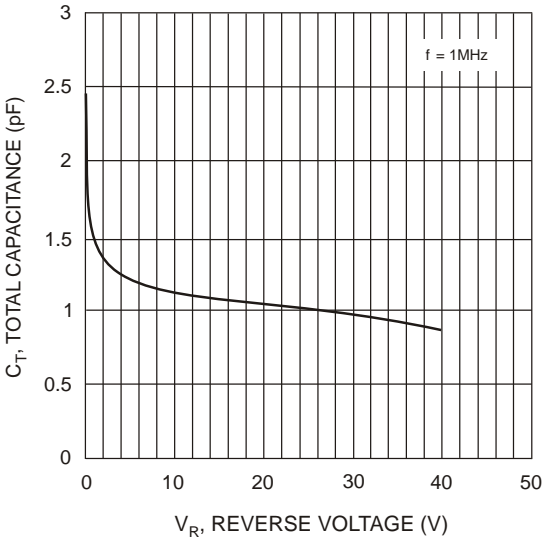

Fig. 19, Typical Capacitance vs. Reverse Voltage (Switching Diode)

Ordering Information (Note 5)

Device	Marking Code	Packaging	Shipping
DRDN010W-7	RD01	SOT-363	3000/Tape & Reel
DRDN005W-7	RD07	SOT-363	3000/Tape & Reel
DRDP006W-7	RD02	SOT-363	3000/Tape & Reel
DRDNB16W-7	RD03	SOT-363	3000/Tape & Reel
DRDNB26W-7	RD04	SOT-363	3000/Tape & Reel
DRDPB16W-7	RD05	SOT-363	3000/Tape & Reel
DRDPB26W-7	RD06	SOT-363	3000/Tape & Reel

Notes: 5. For Packaging Details, go to our website at <http://www.diodes.com/datasheets/ap02007.pdf>.

Marking Information

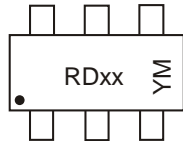

RDxx = Product Type Marking Code
YM = Date Code Marking
Y = Year ex: S = 2005
M = Month ex: 9 = September

Date Code Key

Year	2005	2006	2007	2008	2009
Code	S	T	U	V	W

Month	Jan	Feb	March	Apr	May	Jun	Jul	Aug	Sep	Oct	Nov	Dec
Code	1	2	3	4	5	6	7	8	9	O	N	D

Sample Applications

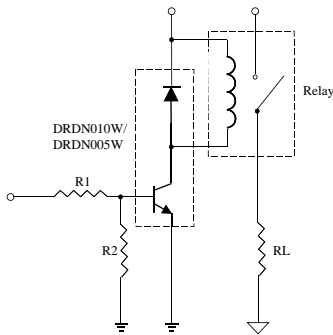

Application Example: DRDN010W/DRDN005W current sink configuration, bias resistors not included

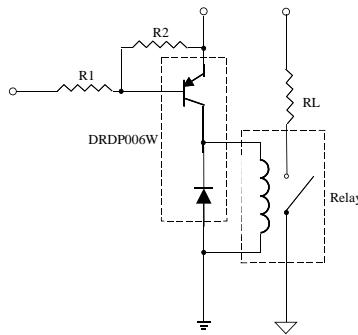

Application Example: DRDP006W current source configuration, bias resistors not included

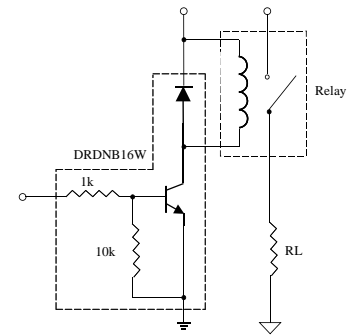

Application Example: DRDNB16W current sink configuration with built-in bias resistors

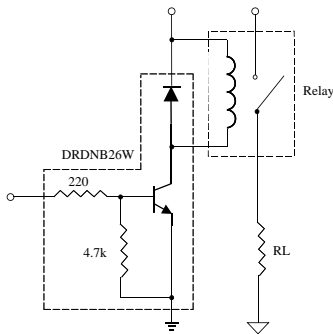

Application Example: DRDNB26W current sink configuration with built-in bias resistors (low R1)

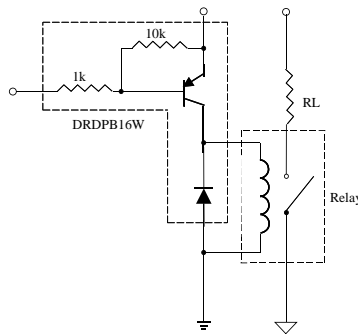

Application Example: DRDPB16W current source configuration with built-in bias resistors

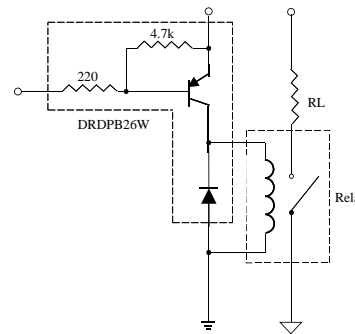

Application Example: DRDPB26W current source configuration with built-in bias resistors (low R1)