

PHASE NOISE (1 Hz BW, typical)

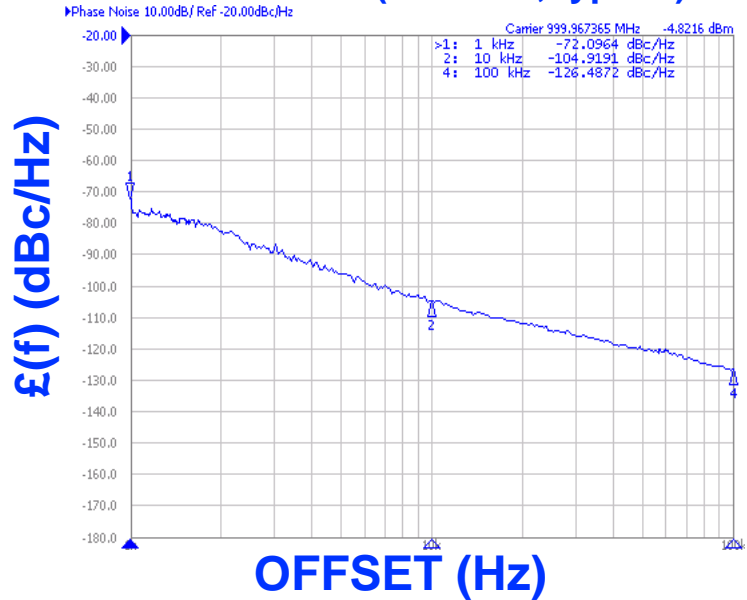

FEATURES
<ul style="list-style-type: none"> • Frequency Range: 900 - 1100 MHz • Tuning Voltage: 0.5-5 Vdc • SUB-L - Style Package
APPLICATIONS
<ul style="list-style-type: none"> • Digital Cellular • VHF Communications • Test Equipment

PERFORMANCE SPECIFICATIONS	VALUE	UNITS
Oscillation Frequency Range	900 - 1100	MHz
Phase Noise @ 10 kHz offset (1 Hz BW, typ.)	-102	dBc/Hz
Harmonic Suppression (2nd, typ.)	-15	dBc
Tuning Voltage	0.5-5	Vdc
Tuning Sensitivity (avg.)	79	MHz/V
Power Output	0±2	dBm
Load Impedance	50	Ω
Input Capacitance (max.)	50	pF
Pushing	<3	MHz/V
Pulling (14 dB Return Loss, Any Phase)	<2	MHz
Operating Temperature Range	-40 to 85	°C
Package Style	SUB-L	
POWER SUPPLY REQUIREMENTS		
Supply Voltage (Vcc, nom.)	5	Vdc
Supply Current (Icc, typ.)	15	mA

All specifications are typical unless otherwise noted and subject to change without notice.

APPLICATION NOTES
<ul style="list-style-type: none"> • AN-100/1 : Mounting and Grounding of VCOs • AN-102 : Proper Output Loading of VCOs • AN-107 : How to Solder Z-COMM VCOs
NOTES:

TUNING CURVE, typ.

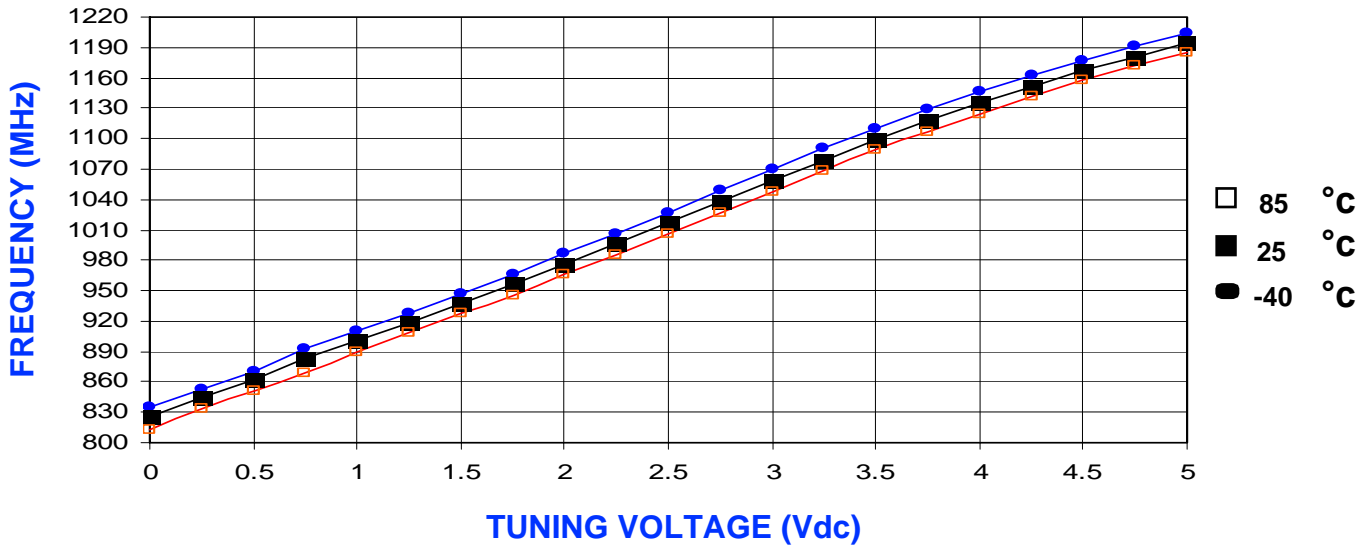

POWER CURVE, typ.

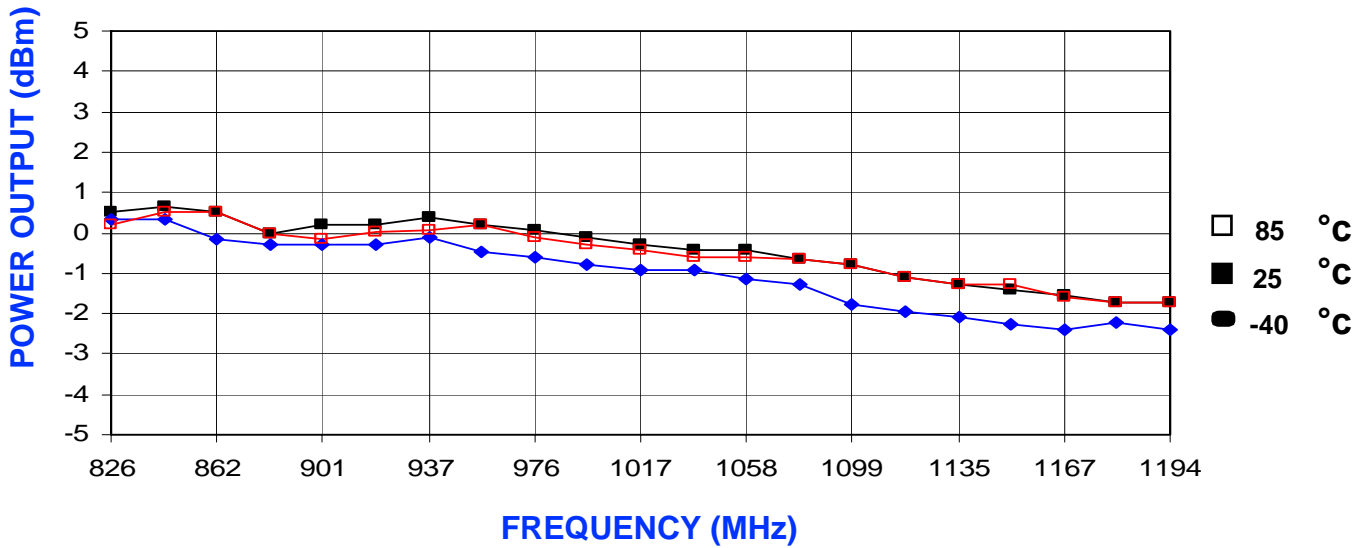

PHYSICAL DIMENSIONS

SUB-L
415-0040 REV. D
(DRAWING NOT TO SCALE)

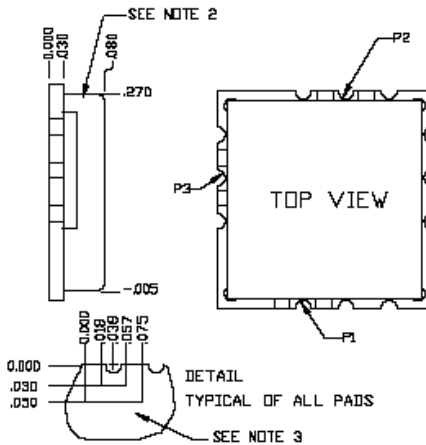
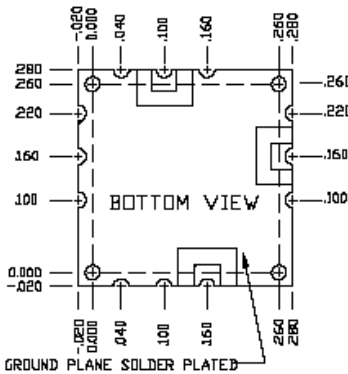

NOTES:

1. THE INSIDE RADIUS OF ALL 12 HALF HOLES AT THE PERIMETER OF THE BOARD ARE SOLDER PLATED TO PROVIDE A SURFACE FOR THE ATTACHMENT OF THE VCO TO THE MOTHERBOARD.
2. THE SHIELD MATERIAL IS NICKEL SILVER AND MAY BE SOLDERED ALSO.
3. THE GROUND PLANE IS GROUND AND ATTACHES TO THE GROUND TRACK ON THE UPPER SIDE OF THE BOARD AS WELL AS THE SHIELD BY PTH.

TOLERANCES UNLESS OTHERWISE NOTED

.XXX ± .010

P1= VT
P2= RF OUT
P3= Vcc