

FEATURES

- Dual current-controlled output current sources with 4 input channels
- TTL-selectable output
- Stable on-chip oscillators with independent frequency and amplitude control
- TTL- or LVDS-selectable write channel enables
- TTL- or LVDS-selectable oscillator enable
- 150 mA minimum output current for Read Channel
- 275 mA minimum output current for Write Channel 1
- 170 mA minimum output current for Write Channel 2
- 150 mA minimum output current for Write Channel 3
- Rise time/fall time of ≤ 0.8 ns
- Low output overshoot
- Low power consumption
- Single 5 V power supply ($\pm 10\%$)

APPLICATIONS

- DVD-R, DVD+R, DVD-RW, DVD+RW, DVD-RAM supercombo drives
- MO drives
- Laser diode current switching

GENERAL DESCRIPTION

The AD9668 is a laser diode driver for high performance CD-RW and DVD recordable drives. It includes four channels for four different optical power levels; the Read Channel generates a continuous output power level, whereas Channel 1, Channel 2, and Channel 3 can be used as write channels that can be controlled with either an LVDS or a TTL interface. The OSCEN pin is also controlled by either an LVDS or a TTL signal. All channels are summed at the selected LD output pin, where Write Channel 1 can contribute at least 275 mA output current, and Write Channel 2 and Write Channel 3 can contribute at least 170 mA and 150 mA, respectively. The level of the output current is set by an external resistor that converts an input voltage into a current at the xSET pins.

An on-chip oscillator is provided to allow output current modulation and to reduce laser mode hopping. Four external resistors permit the setting of two different values for both oscillator frequency and amplitude, one for each output. The oscillator can output up to 100 mA p-p of current (push-pull oscillator) with a frequency range of 200 MHz to 500 MHz.

Rev. Sp0

Information furnished by Analog Devices is believed to be accurate and reliable. However, no responsibility is assumed by Analog Devices for its use, nor for any infringements of patents or other rights of third parties that may result from its use. Specifications subject to change without notice. No license is granted by implication or otherwise under any patent or patent rights of Analog Devices. Trademarks and registered trademarks are the property of their respective owners.

FUNCTIONAL BLOCK DIAGRAM

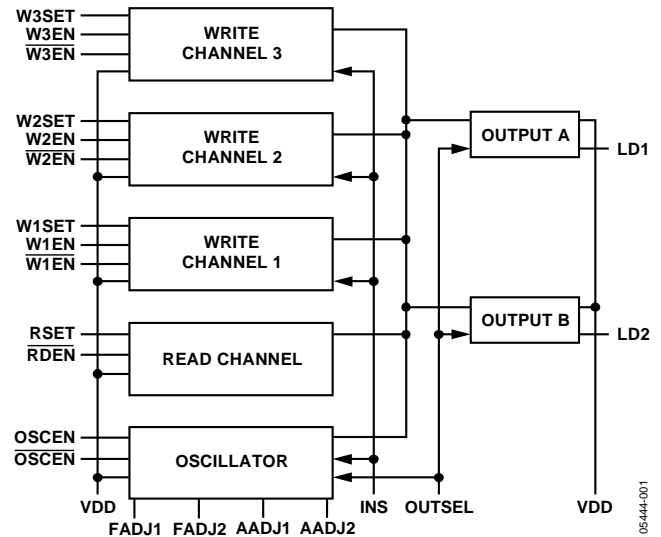
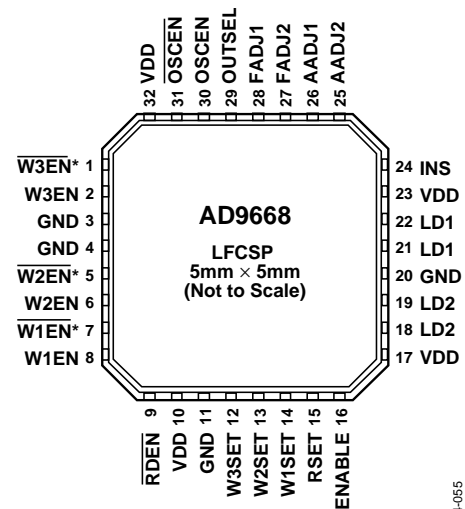

Figure 1. 4-Channel LVDS Laser Driver Block Diagram



*ACTIVE LOW.

Figure 2. 4-Channel, LVDS, Laser-Driver Pin Configuration

For more information about the AD9668, contact Analog Devices, Inc. at high_current_drivers.com@analog.com.

AD9668