

TRIPLE 2-CHANNEL MULTIPLEXER

■ GENERAL DESCRIPTION

The NJU4053B is a triple 2-channel multiplexer with three independent control inputs and an inhibit input.

The three control input signals select 1 of a pair of channels to be turned on and connect them to the three outputs.

The operating voltage is as wide as 3 to 18V and the quiescent current is as low as 5μA max. (at V_{DD}=5V).

It is equivalent to RCA CD4053B and Motorola MC14053B.

■ FEATURES

- High ON/OFF Output Voltage Ratio
 - 65dB Typ. (R_L=10kΩ)
- Low Quiescent Current
 - 5μA Typ. at V_{DD}=5V
- Low Crosstalk between channels
 - 80dB Typ.
- Wide Operating Voltage
 - 3 ~ 18V
- Linearity in the transfer characteristics.
 - ΔR_{ON} < 60Ω (V_{IN}=V_{DD}~V_{EE}, V_{DD}=15V)
- Package Outline
 - DIP/DMP 16
- C-MOS Technology

■ PACKAGE OUTLINE

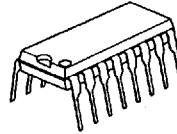

NJU4053BD

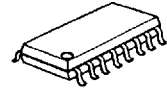

NJU4053BM

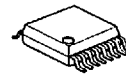

NJU4053BV

■ EQUIVALENT CIRCUIT

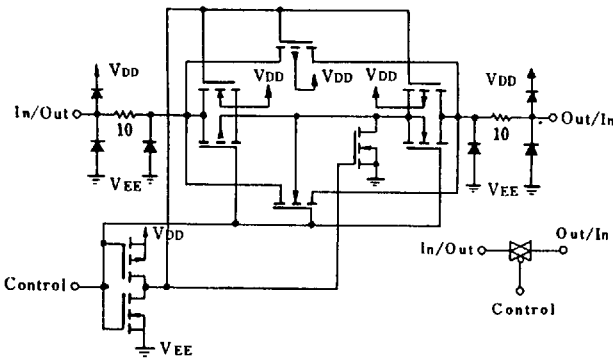

■ PIN CONFIGURATION

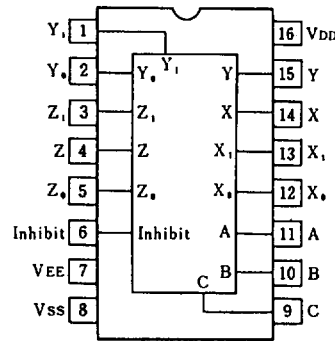

■ BLOCK DIAGRAM

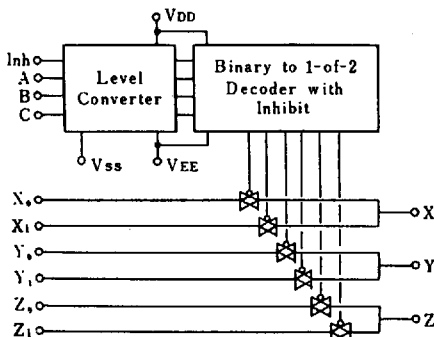

■ TRUTH TABLE

INH	C	B	A	On Switch		
0	0	0	0	Z ₀	Y ₀	X ₀
0	0	0	1	Z ₀	Y ₀	X ₁
0	0	1	0	Z ₀	Y ₁	X ₀
0	0	1	1	Z ₀	Y ₁	X ₁
0	1	0	0	Z ₁	Y ₀	X ₀
0	1	0	1	Z ₁	Y ₀	X ₁
0	1	1	0	Z ₁	Y ₁	X ₀
0	1	1	1	Z ₁	Y ₁	X ₁
1	x	x	x	None		

x: Don't Care

7

■ ABSOLUTE MAXIMUM RATINGS

(Ta=25°C)

PARAMETER	SYMBOL	RATINGS	UNIT
Supply Voltage	$V_{DD} - V_{EE}$	- 0.5 ~ + 20	V
Input Voltage(Control Signal)	V_{IN}	$V_{SS}-0.5 \sim V_{DD}+0.5$	V
Input Voltage(Analog Signal)	V_{SIG}	$V_{EE}-0.5 \sim V_{DD}+0.5$	V
Input Current	I_{IN}	± 10	mA
Output Current	I_{OUT}	± 10	mA
Power Dissipation	P_D	500 (DIP) 200 (DMP) 300 (SSOP)	mW
Operating Temperature Range	T_{opr}	- 40 ~ + 85	°C
Storage Temperature Range	T_{stg}	- 65 ~ + 150	°C

■ ELECTRICAL CHARACTERISTICS

• DC Characteristics

 ($V_{SS}=0V$)

PARAMETER	SYMBOL	CONDITIONS	V_{DD} (V)	Ta=-40°C		Ta=25°C		Ta=85°C		UNIT
				MIN	MAX	MIN	TYP	MAX	MIN	
Quiescent Current	I_{DD}	No signal Per Package	5 10 15 20	5 10 20 100	5 10 20 100	5 10 20 100	150 300 600 3000		μA	
On-State Resistance	R_{ON}	$0 \leq V_{i_s} \leq V_{DD}$ $V_{EE}=V_{SS}=0V$	5 10 15	500 210 140	220 100 60	600 250 160	800 300 200		Ω	
On-State Resistance Deviation	ΔR_{ON}	Between 2 channels $V_{EE}=V_{SS}=0V$	5 10 15		15 10 5				Ω	
Off-Channel Leakage Current		Each channel $V_{EE}=V_{SS}=0V$	18	± 1000	± 10	± 100	± 1000		nA	
Input Capacitance	C_{IN}	$V_{IN}=0V$ Control Inhibit Switch			5.0 10	7.5			pF	
Low Level Input Voltage	V_{IL}	$R_L=10k\Omega$ $SW=V_{DD}$ $V_{EE}=V_{SS}$	5 10 15	1.5 3.0 4.0		1.5 3.0 4.0	1.5 3.0 4.0		V	
High Level Input Voltage	V_{IH}		5 10 15	3.5 7.0 11.0		3.5 7.0 11.0	3.5 7.0 11.0		V	
Input Current	$\pm I_{IN}$	$V_{IN}=0$ or 18V	18	± 0.1		± 0.1	± 1		μA	

SWITCHING CHARACTERISTICS

 ($T_a=25^\circ\text{C}$, $C_L=50\text{pF}$)

PARAMETER		SYMBOL	CONDITIONS	$V_{DD}(V)$	MIN	TYP	MAX	UNIT
Propagation Delay Time	SW Input to Output	t_{PLH}	$R_L=10\text{k}\Omega$	5	15	45	ns	
				10	8	30		
				15	5	20		
	CONT Input to Output	t_{PHL}		5	15	45		
				10	8	30		
				15	5	20		
	t_{PZH}	5	450	1000	ns			
		10	200	500				
		15	150	400				
Output Enable Time	t_{PHZ}	$R_L=10\text{k}\Omega$	5	600		1400	ns	
			10	250		700		
			15	200		500		
Output Disable Time	t_{PLZ}		5	600	1400	ns		
			10	250	700			
			15	200	500			
Sine-Wave Distortion			$R_L=10\text{k}\Omega$, $f=1\text{kHz}$, $V_{IS}=5V_{P-P}$	10	0.05		%	
Feedthrough (all-ch. off)			$R_L=1\text{k}\Omega$, $20\log_{10}V_{os}/V_{IS}=-50\text{dB}$	10	4.5		MHz	
Crosstalk	SW A to B		$R_L=1\text{k}\Omega$, $V_{IS}=1/2(V_{DD}-V_{SS})_{P-P}$	10	3.0		MHz	
	Control-Out		$R_1=1\text{k}\Omega$, $R_L=10\text{k}\Omega$, $tr=tf=20\text{ns}$ CONTROL/INHIBIT	10	30		mV	

7

■ MEASUREMENT CIRCUITS

1. Noise Margine

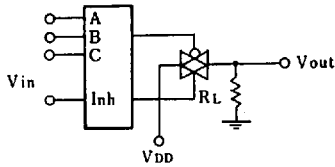

2. Propagation Delay

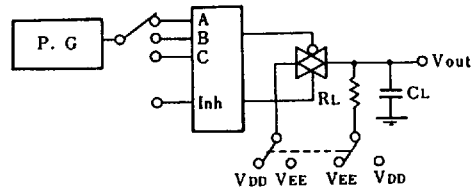

3. Feedthrough

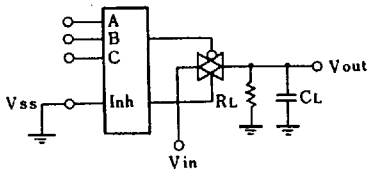

$$\frac{V_{DD} - V_{EE}}{2} \rightarrow$$

4. Crosstalk (Switch A and B)

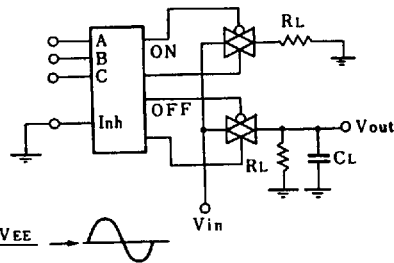

$$\frac{V_{DD} - V_{EE}}{2} \rightarrow$$

5. Crosstalk (Control and Out)

