



30KB Ultra Low Cost Flash Smart Card IC

Environment

- Voltage Supply Class A, B: 3.0V to 5.0V ± 10%
- 25 to +85 °C Operating Temperature
- Max supply current 6mA @ 15MHz, Class B
- > 4 kV ESD Protection HBM

CPU

- Software compatible CMOS 80X51 industry standard
- Accelerated architecture with 16 bit CPU performance level
- Up to 30 MHz internal CPU clock

Idle Modes

- Idle and Stop mode selectable modes
- NVM update operation with CPU in idle/halt mode
- IO Transmission and Reception with CPU in idle mode
- Max Idle current / Clock stopped : 100 uA

Security

- Unique chip identification number
- Notification of tampering
- Internal clock generation
- IC operates under regulated voltage
- DPA/SPA resistance mechanisms
- Under / Over voltage sensors (Vcc)

Memory Control

- General Purpose Non Volatile Memory: GPNVM
- Secure Memory Management Mechanism
- Fast Byte program: 40 us / Byte
- GP NVM Page Erase: 2 ms

I/O

- ISO 7816-3 compliant electrical interface
- ISO 7816-3 compliant interface with T=0 and T=1 protocols
- ETU Timer/Counter replacing 8051 T0/T1 Timers

Memories

- 768 bytes RAM (256B Local RAM + 512B XRAM)
- 30KB GPNVM (User) = 240 Pages of 128 B
 - User Code, constant storage (ROM)
 - User Non Volatile Data storage (EEPROM)
- 1KB GPNVM (System) = 8 Pages of 128 B
 - System parameters
 - Loader extensions
 - Backup buffer / hard API code
- 10 years data retention
- GPNVM Cycling Endurance > 100 K cycles
- BootROM loader T0 and T14 compatible
- Boot loader commands set extension capabilities

Chip Forms

- 8" Wafer sawn or unsawn
- Back grinding and distressing options
- 180 microns max thickness
- Modules

Typical Application:

- SIM card GSM Phase2 or Phase2+ 16KB

- ✓ **Development tools fully integrated within Keil uVision2/3**
- ✓ **DevKit emulator, examples, documentation samples**

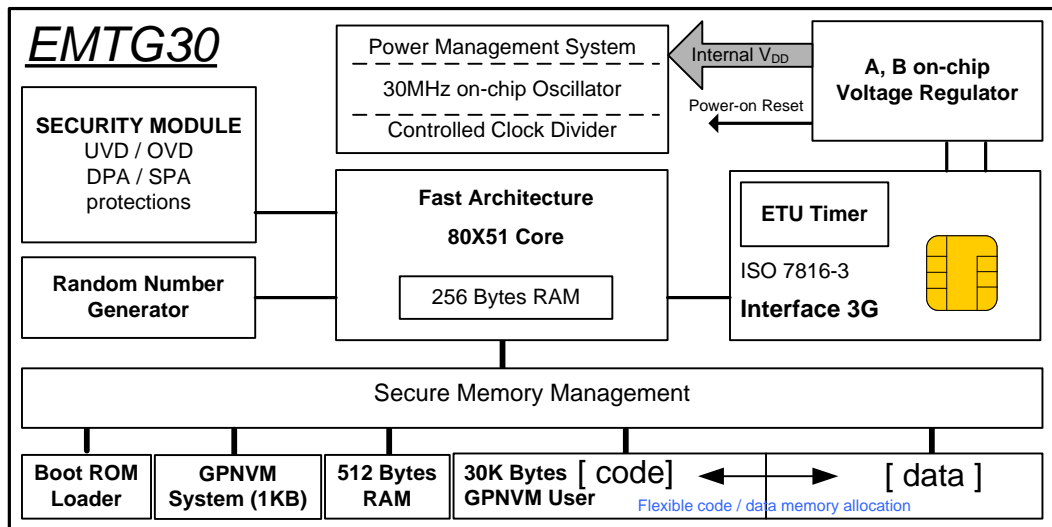



Introduction

EMTG30 is a member of the Theseus family of devices designed specifically for smart card applications. It is software compatible with the industry standard 8051 micro-controller, to guarantee the maximum availability of qualified software. The hardware implementation of the core is a modern design not relying on microcode, with an increase of up to 4 times on a standard 8051's clocks per instruction.

Security of the family of devices makes them particularly suitable in electronic commerce and sensitive data areas. This is accomplished in hardware, with not only protection against out of parameter operation of the device, but hardware memory management to protect against software security attacks. The CPU clock is derived from its own internal oscillator, so preventing attacks by clock manipulation, or extrapolating program execution by monitoring current variations on clock edges.

General Purpose Non Volatile Memory (GPNVM)

The General Purpose Non Volatile Memory offers ultra low cost implementation of traditional EEPROM based smart card ICs using one unique memory instance for code and data storage. This one memory solution provides compact implementation offering at the same time a maximum flexibility. Therefore all code size footprint reduction will directly benefits to the application.

A simple and secure memory protection mechanism is relying on a flexible border between code and data space.

With up to a 30KB GPNVM on chip memories EMTG30 eradicates the need for memory bank switching either for data and code space.

The organisation of GPNVM in 128 bytes per pages combined with efficient page management methods are increasing application level performances such as:

- High performances memory update
- High resistance to page tearing
- Extension of application level effective page cycling endurance
- Simple implementation of anti-tearing mechanism

An additional GPNVM system area of 1KB is available. This system area hosts device systems parameters. The remaining area could be used for several purposes such boot loader commands extension, GPNVM update backup buffer, hardware API functions etc...

This means that reel User's available memory is actually larger than 30KB.

Serial interface

EMTG30 offers a unique serial interface compliant with the ISO 7816-3 specification with several modes implemented allowing serial connections at 9600 up to 357K bits per second at 3.57MHz. EMTG30 supports T=0 asynchronous half duplex character transmission protocol, T=1 asynchronous half duplex block transmission and a proprietary T=14 protocol used for fast loading of Code into the OTP by the card manufacturer. It handles minimum guard time requirements between characters specified by ISO7816-3 specification automatically. EMTG30 is designed to be compatible with the ISO7816-3 specification defining the characteristics of Integrated Circuit Cards commonly referred to as smart cards.

Random Number Generator

The on chip random number generator is fully Fips140-2 compliant, providing a rapid stream of truly random numbers. This allows use of the random numbers generated beyond just the provision of numbers for randomising transmissions or generating keys.

Clocks

EMTG30 has its own internal oscillator this allows the core of the device to be independent of the external clock. The processor can also be clocked much faster than the IO CLK signal. This ensures the elimination of fraudulent attacks involving frequency jitter and unequal mark space ratios. The internal clock generator is connected to the core via a divider that is under the control of the software. This allows the Operating System writer to control the trade off between execution speed and power drawn by the device. Extending battery life in hand help applications where slow interfaces are involved.

Anti tampering

The EMTG30 has extensive anti tampering provision including the monitoring of the connection to the device to ensure that deviations beyond a prescribed criteria result in the device being closed down before its operating conditions are violated.

On chip voltage regulators

Several on chip regulators isolate the various elements of the device from variations and fluctuations in the supply voltage. This allows elements to be characterised precisely, as they operate at one fixed voltage, which in turn maximises the endurance of the device.

Technology

This product is using superior Flash memory SuperFlash Technology licensed from SST and SuperFlash is a registered trademark of SST (Silicon Storage Technology Inc.).



Technical Data

Absolute Maximum Ratings

Parameter	Symbol	Limit Values			Unit
		min	typical	max	
Supply Operating Volt	V_{cc}	-0.3		6	V
Voltage at remaining pin	V_{pin}	$V_{ss} - 0.3$		$V_{cc} + 0.3$	V
Power dissipation	P_{tot}			+60	mW
Storage temperature	I_{ccl}	-40		+125	°C

DC Characteristics

Parameter	Symbol	Limit Values			Unit
		min	typical	max	
Operating temperature	T_A	-25		+85	°C
Supply Voltage Class A,B	V_{cc}	2.7	3 / 5	5.5	V
Supply Current Class B	I_{cc}			6 (Note 1)	mA
Supply Current idle	I_{ccl}			200 (Note 2)	μA
Supply Current stopped	I_{ccs}			100 (Note 3)	μA

Note 1: The supply current refers to clock frequency of 5 Mhz

Note 2: The supply current at 3.3V and a clock frequency of 1 Mhz, at +25 °C

Note 3: The supply current at 3.3V and +25 °C

IO pin:

Parameter	Symbol	Conditions	min	max	Unit
H input voltage	V_{IH}	$I_{Ihmax} = \pm 20 \mu A$	$0.7 * V_{cc}$	V_{cc}	V
L input voltage	V_{IL}	$I_{ILmax} = \pm 20 \mu A$	-0.3	0.8	V
H output voltage (Note 1)	V_{OH}	$I_{Ohmax} = +20 \mu A$	$0.7 * V_{cc}$	V_{cc}	V
L output voltage	V_{OL}	$I_{Olmax} = -1mA$	0	0.4	V
Rise Fall Time	t_r, t_f	$C_{IN} = C_{OUT} = 30 pF$		1	μS

NOTE 1: Assumes 20KΩ Pull up resistor on interface device

Clock (CLK)

Parameter	Symbol	Condition	Min	Max	Unit
H output voltage	V_{OH}	$I_{Ohmax} = +20 \mu A$	$V_{cc} - 0.7$	V_{cc}	V
L output voltage	V_{OL}	$I_{Olmax} = -20 \mu A$	0	0.5	V
Rise Fall Time	t_r, t_f	$C_{IN} = C_{OUT} = 30 pF$		9% CLK period	

Reset(RST)

Parameter	Symbol	Condition	Min	Max	Unit
H output voltage	V_{OH}	$I_{Ohmax} = +20 \mu A$	$V_{cc} - 0.7$	V_{cc}	V
L output voltage	V_{OL}	$I_{Olmax} = -20 \mu A$	0	0.6	V
Rise Fall Time	t_r, t_f	$C_{IN} = C_{OUT} = 30 pF$		400	μs

EM Microelectronic-Marín SA (EM) makes no warranty for the use of its products, other than those expressly contained in the Company's standard warranty which is detailed in EM's General Terms of Sale located on the Company's web site. EM assumes no responsibility for any errors which may appear in this document, reserves the right to change devices or specifications detailed herein at any time without notice, and does not make any commitment to update the information contained herein. No licenses to patents or other intellectual property of EM are granted in connection with the sale of EM products, expressly or by implications. EM's products are not authorized for use as components in life support devices or systems.

© EM Microelectronic-Marín SA, 07/05, Rev. A/005