



IGBT Ignition Predriver with Dynamic Current Regulation

Description

The CS8312 is a bipolar microprocessor interface IC designed to drive an IGBT (or logic level MOSFETs) powering large inductive loads in harsh operating environments. The IC's dynamic current limit function lets the microprocessor adjust the current limit threshold to the real time needs of the system.

CLI, the current limit input, sets the current limit for the IGBT high or low as directed by the system microprocessor. CLI also raises and lowers the threshold on the diagnostic FLAG output signal. The FLAG output signals the microprocessor when the current level approaches current limit on the IGBT. The CTRL input enables the FLAG function.

Features

- μ P Compatible Inputs
- Adjustable Current Limit Thresholds
- External Sense Resistor
- Flag Signal to Indicate Output Status

Absolute Maximum Ratings

Supply Voltage.....	-0.3V to +12V
Digital Input Currents.....	2mA
Internal Power Dissipation (T _A = 25°C)	700mW
Junction Temperature Range.....	-40°C to +150°C
Storage Temperature Range	-55°C to +165°C
Lead Temperature Soldering	
Wave Solder(through hole styles only).....	10 sec. max, 260°C peak
Reflow (SMD styles only).....	60 sec. max above 183°C, 230°C peak
Electrostatic Discharge (Human Body Model)	2kV

Block Diagram

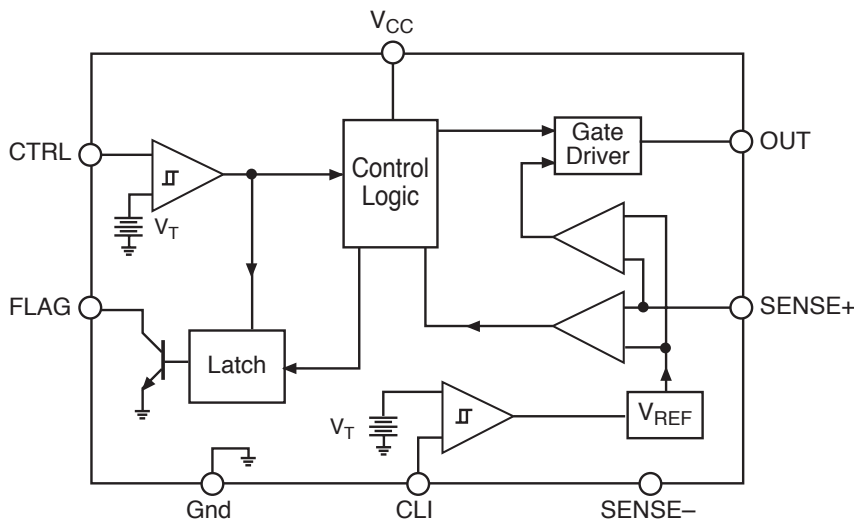

Package Options

8L PDIP & SO Narrow

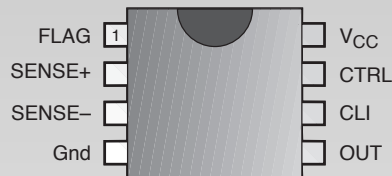

Cherry Semiconductor Corporation
 2000 South County Trail, East Greenwich, RI 02818
 Tel: (401)885-3600 Fax: (401)885-5786
 Email: info@cherry-semi.com
 Web Site: www.cherry-semi.com

Electrical Characteristics $7V \leq V_{CC} \leq 10V$; $-40^{\circ}C \leq T_A \leq +125^{\circ}C$; unless otherwise specified

PARAMETER	TEST CONDITIONS	MIN	TYP	MAX	UNIT
■ General					
Power Supply including Ripple Voltage		7		10	V
Supply Ripple Frequency		10		60	kHz
Differential Ground Voltage	DC SENSE- to Gnd	-0.1		1.0	V
	AC SENSE- to Gnd	-0.2		0.6	V
Differential Ground Frequency		10		60	kHz
Quiescent Current, I_Q					
Turn On	$V_{CTRL}=5.5V$			15	mA
Turn Off	$V_{CTRL}=-0.3V$			5	mA
Supply Voltage Rejection	$V_{CTRL}=5.5V$	30			dB
Differential Ground Rejection Ratio	$V_{CTRL}=5.5V$	30			dB
Differential Ground Current Ratio	$V_{CTRL}=-0.3V$ ($V_{SENSE-}-V_{Gnd}$)DC=1V ($V_{SENSE-}-V_{Gnd}$)AC=0.6V			3	mA
Unity Gain Bandwidth	$V_{CTRL}=5.5V$	400			kHz
Clamp Voltage	$V_{CTRL}=5.5V$; $I_{OUT}=1mA$			5.5	V
Output Off Voltage	$V_{CTRL}=-0.3V$; $I_{OUT}=10\mu A$			0.5	V
	$V_{CTRL}=-0.3V$; $I_{OUT}=200\mu A$			1.2	V
Turn On Delay	CTRL increasing			30	us
Turn Off Delay	CTRL decreasing			30	us
■ Control Function					
Input Voltage Range	$I_{CTRL}=2mA$	-0.3		5.5	V
Input Threshold					
Turn On	CTRL increasing			3.5	V
Turn Off	CTRL decreasing	1.5			V
Hysteresis		0.4		2.0	V
Voltage	$I_{CTRL}=10\mu A$ MAX			1.1	V
Input Capacitance				50	pF
■ Current Limit Increase Function					
Input Voltage Range	$I_{CTRL}=2mA$	-0.3		5.5	V
Input Threshold					
Turn On	CLI increasing			3.5	V
Turn Off	CLI decreasing	1.5			V
Hysteresis		0.4		2.0	V
Voltage	$I_{CLI}=10\mu A$ max			1.1	V
Input Capacitance				50	pF
■ Output Stage					
I_{OUT}				5	mA
■ Flag Function					
Output Low	$V_{CTRL}=5.5V$; $I_{FLAG}=1.5mA$			0.9	V
Leakage Current	$V_{CTRL}=-0.3V$			10	μA
Output Capacitance				50	pF
Turn On ($V_{SENSE+}-V_{SENSE-}$)	$V_{CTRL}=5.5V$; $V_{CLI}=-0.3V$	210	225	240	mV
	$V_{CTRL}=5.5V$; $V_{CLI}=5.5V$	300		350	mV

Electrical Characteristics continued

PARAMETER	TEST CONDITIONS	MIN	TYP	MAX	UNIT
■ Flag Function: continued					
Turn Off Delay	CTRL decreasing			10	us
Turn On Delay				10	us
Disable Time		100		450	us
■ Sense Function					
Input Voltage Range		-0.3		2.5	V
Sense Regulation Voltage	$V_{CTRL}=5.5V; V_{CLI}=-0.3V$	270	295	320	mV
	$V_{CTRL}=5.5V; V_{CLI}=5.5V$	380	410	440	mV
Input Leakage Current	$V_{CTRL}=5.5V$			5	μA
Propagation Delay	$V_{CTRL}=5.5V$			20	us

Package Pin Description

PACKAGE PIN #	PIN SYMBOL	FUNCTION
8L PDIP & SO		
1	FLAG	Indicates whether current through the IGBT has reached a pre-set level.
2	SENSE+	Positive input to current comparator.
3	SENSE-	Ground (SENSE-) for current sense resistor.
4	Gnd	Ground connection.
5	OUT	Output voltage to IGBT (MOSFET) gate.
6	CLI	Current limit input increase.
7	CTRL	Control input.
8	V_{CC}	Supply voltage.

Circuit Description

Flag Function (see Application Diagram)

The flag indicates when the voltage across the two sense pins is approaching a current limit level that has been determined by the value of the external sense resistor (R_{SENSE}) and the state of the CTRL and CLI pins. If the voltage across the sense pins (SENSE+, SENSE-) is less than the flag turn-on voltage, then the FLAG is off. When the voltage between the sense pins equals the FLAG turn on voltage, the FLAG will latch on until the CTRL pin goes low. FLAG is disabled whenever CTRL is low. Changing the CLI pin from low to high will increase nominal FLAG turn on voltage by approximately 45%.

Table 1 FLAG Timing Sequence

State	CONTROL	SENSE+	FLAG
0	Low	X	OFF
1	High	Below Threshold	OFF
2	High	Above Threshold	ON
3	High	X	ON
0	Low	X	OFF

Output Stage

The CS8312 output (OUT) saturates and supplies voltage to the IGBT (or MOSFET) gate once the CTRL switches from low to high. As current through the IGBT (MOSFET) increases and the voltage across the sense resistor passes the flag turn on voltage, the FLAG will turn on. If the current through the sense resistor continues to rise and the sense resistor voltage reaches the regulation sense voltage, then the gate voltage will fall to a level that regulates the driver and maintains the regulation sense voltage at the sense resistor.

Current Limit Function

Changing the CLI pin from a logic low to a logic high increases the FLAG turn on voltage by approximately 45% and the regulation sense voltage by approximately 39% respectively.

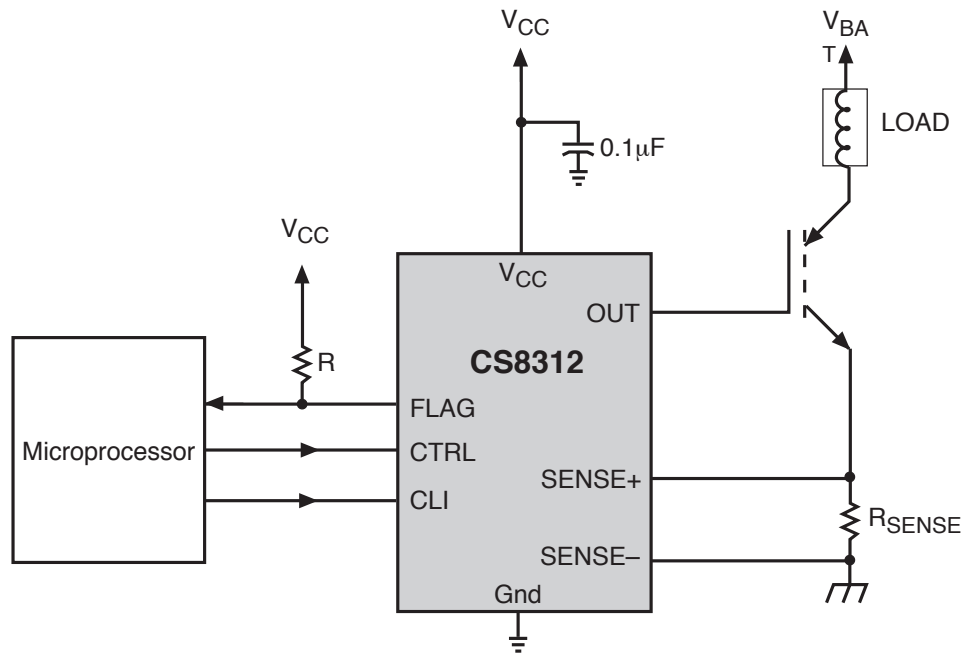

Package Specification

PACKAGE DIMENSIONS IN mm (INCHES)

Lead Count	D			
	Metric		English	
	Max	Min	Max	Min
8 Lead SO Narrow	5.00	4.80	.197	.189
8 Lead PDIP	10.16	9.02	.400	.355

PACKAGE THERMAL DATA

Thermal Data		8L SO	8L PDIP	
$R_{\theta JC}$	typ	45	52	°C/W
$R_{\theta JA}$	typ	165	100	°C/W

Surface Mount Narrow Body (D); 150 mil wide

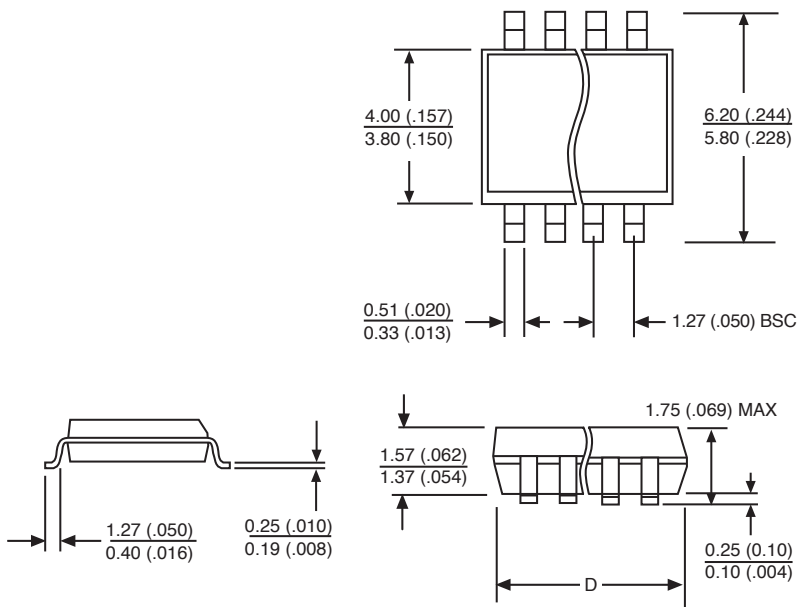

REF: JEDEC MS-012

Plastic DIP (N); 300 mil wide

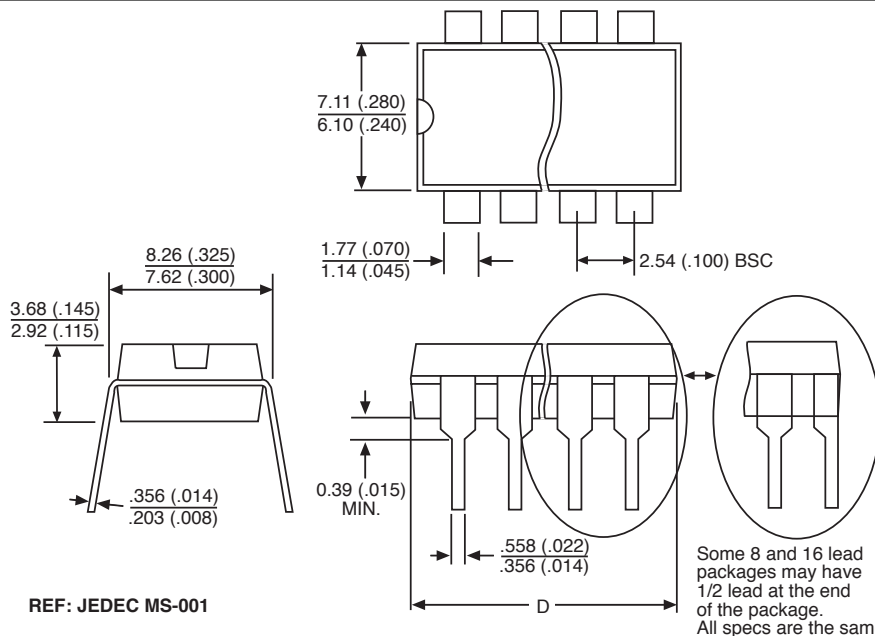

REF: JEDEC MS-001

Ordering Information

Part Number	Description
CS8312YN8	8L PDIP
CS8312YD8	8L SO Narrow
CS8312YDR8	8L SO Narrow (tape & reel)

Cherry Semiconductor Corporation reserves the right to make changes to the specifications without notice. Please contact Cherry Semiconductor Corporation for the latest available information.