



Micropower 5V, 100mA Low Dropout Linear Regulator

Description

The CS8221 is a precision 5V, 100mA micropower voltage regulator with very low quiescent current (60µA typical at 100µA load). The 5V output is accurate within ±2% and supplies 100mA of load current with a maximum dropout voltage of only 600mV.

The regulator is protected against reverse battery, short circuit, over voltage, and over temperature conditions. The device can withstand 74V load dump transients making it suitable for use in automotive environments.

Absolute Maximum Ratings

Power Dissipation	Internally Limited
Transient Peak Voltage (60V Load Dump)	-15V, 74V
Output Current	Internally Limited
ESD Susceptibility (Human Body Model)	.2kV
Junction Temperature	-40°C to 150°C
Storage Temperature	-55°C to 150°C
Lead Temperature Soldering	
Reflow (SMD styles only)	.60 sec. max above 183°C, 230°C peak

Block Diagram

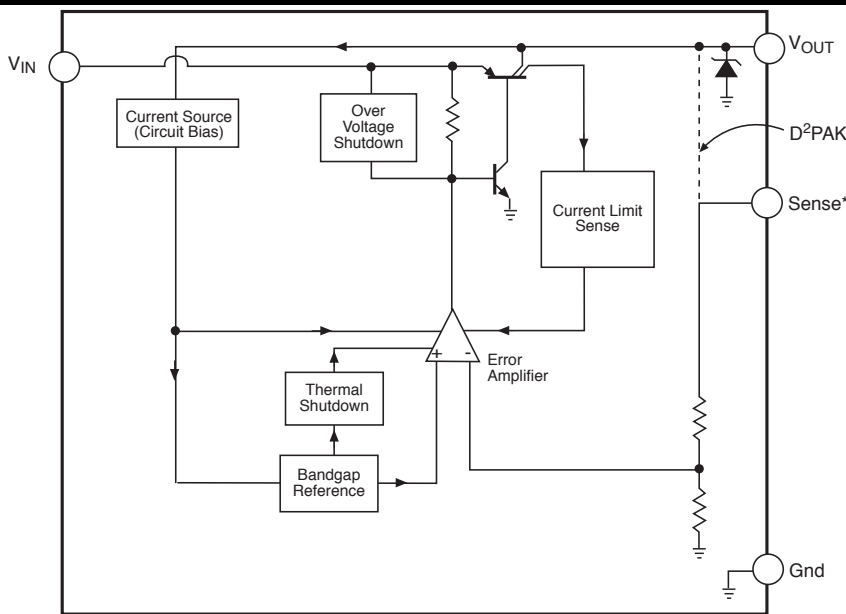

* 8 Lead SO Narrow

Features

- Low Quiescent Current (60µA @ 100µA load)
- 5V, ±2% Output
- 100mA Output Current Capability
- Fault Protection
 - +74V Peak Transient Voltage
 - 15V Reverse Voltage Short Circuit
 - Thermal Shutdown
 - Low Reverse Current (Output to Input)

Package Options

8L SO Narrow
(Internally Fused Leads)

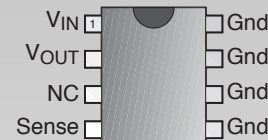

3L D²PAK
Tab (Gnd)

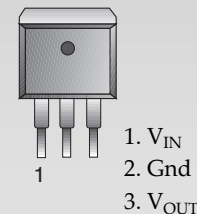

Consult factory for TO-92.



Cherry Semiconductor Corporation
 2000 South County Trail, East Greenwich, RI 02818
 Tel: (401)885-3600 Fax: (401)885-5786
 Email: info@cherry-semi.com
 Web Site: www.cherry-semi.com

Electrical Characteristics: $6V \leq V_{IN} \leq 26V$, $I_{OUT} = 1mA$, $-40^\circ \leq T_A \leq 125^\circ C$, $-40^\circ \leq T_J \leq 150^\circ C$; unless otherwise specified.

PARAMETER	TEST CONDITIONS	MIN	TYP	MAX	UNIT
Output Stage					
Output Voltage, V_{OUT}	$9V < V_{IN} < 16V$, $100\mu A \leq I_{OUT} \leq 100mA$	4.90	5.00	5.10	V
	$6V \leq V_{IN} \leq 26V$, $100\mu A \leq I_{OUT} \leq 100mA$	4.85	5.00	5.15	V
Dropout Voltage ($V_{IN} - V_{OUT}$)	$I_{OUT} = 100mA$		400	600	mV
	$I_{OUT} = 100\mu A$		100	150	mV
Load Regulation	$V_{IN} = 14V$ $100\mu A \leq I_{OUT} \leq 100mA$		5	50	mV
Line Regulation	$6V < V < 26V$ $I_{OUT} = 1mA$		5	50	mV
Quiescent Current, (I_Q)	$I_{OUT} = 100\mu A$, $V_{IN} = 6V$		60	120	μA
	$I_{OUT} \leq 50mA$		4	6	mA
	$I_{OUT} \leq 100mA$		12	20	mA
Ripple Rejection	$7V \leq V_{IN} \leq 17V$, $I_{OUT} = 100mA$, $f = 120Hz$	60	75		dB
Current Limit		125	200		mA
Short Circuit Output Current	$V_{OUT} = 0V$	40	125		μA
Thermal Shutdown (Note 1)		150	180		$^\circ C$
Overvoltage Shutdown	$V_{OUT} \leq 1V$	30	34	38	V
Reverse Current	$V_{OUT} = 5V$, $V_{IN} = 0V$		100	500	μA

Note 1: This parameter is guaranteed by design, but not parametrically tested in production.

Package Lead Description

PACKAGE LEAD #	LEAD SYMBOL	FUNCTION
8L SO Narrow (Internally Fused Leads)	3L D²PAK	
1	1	V_{IN} Input voltage.
2	3	V_{OUT} 5V, $\pm 2\%$, 100mA output.
3	–	NC No connection.
4	–	Sense Kelvin connection which allows remote sensing of the output voltage for improved regulation. If remote sensing is not required, connect to V_{OUT} .
5,6,7,8	2	Gnd Ground.

Voltage Reference and Output Circuitry

Output Stage Protection

The output stage is protected against overvoltage, short circuit and thermal runaway conditions (Figure 1).

If the input voltage rises above 34V (typ), the output shuts down. This response protects the internal circuitry and enables the IC to survive unexpected voltage transients.

Should the junction temperature of the power device exceed 180°C (typ) the power transistor is turned off. Thermal shutdown is an effective means to prevent die overheating since the power transistor is the principle heat source in the IC.

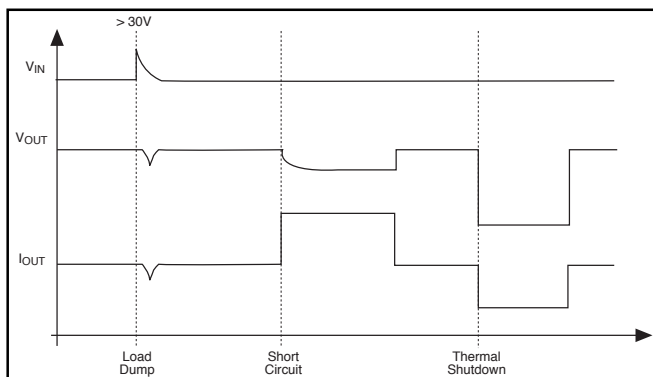
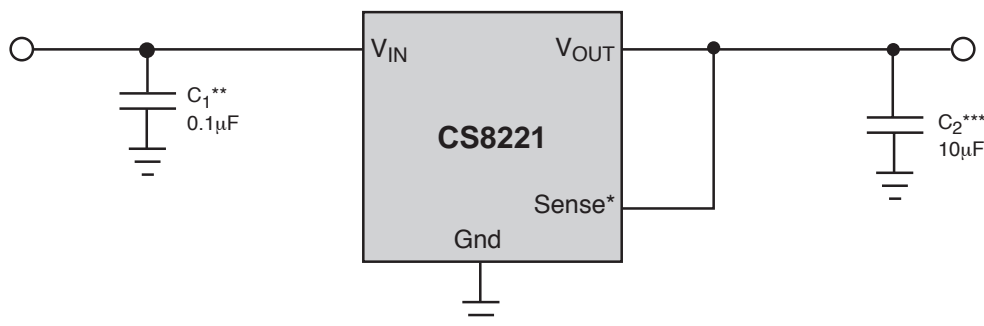

Figure 1. Typical Circuit Waveforms for Output Stage Protection.

Application & Test Diagram



* 8 Lead SO Narrow only

**C1 is required if regulator is distant from power source filter.

***C2 is required for stability.

Application Notes

Stability Considerations

The output or compensation capacitor helps determine three main characteristics of a linear regulator: start-up delay, load transient response and loop stability.

The capacitor value and type should be based on cost, availability, size and temperature constraints. A tantalum or aluminum electrolytic capacitor is best, since a film or ceramic capacitor with almost zero ESR can cause instability. The aluminum electrolytic capacitor is the least expensive solution, but, if the circuit operates at low temperatures (-25°C to -40°C), both the value and ESR of the capacitor will vary considerably. The capacitor manufacturers data sheet usually provides this information.

The value for the output capacitor C_{OUT} shown in the test and applications circuit should work for most applications, however it is not necessarily the optimized solution.

To determine an acceptable value for C_{OUT} for a particular application, start with a tantalum capacitor of the recommended value and work towards a less expensive alternative part.

Step 1: Place the completed circuit with a tantalum capacitor of the recommended value in an environmental cham-

ber at the lowest specified operating temperature and monitor the outputs with an oscilloscope. A decade box connected in series with the capacitor will simulate the higher ESR of an aluminum capacitor. Leave the decade box outside the chamber, the small resistance added by the longer leads is negligible.

Step 2: With the input voltage at its maximum value, increase the load current slowly from zero to full load while observing the output for any oscillations. If no oscillations are observed, the capacitor is large enough to ensure a stable design under steady state conditions.

Step 3: Increase the ESR of the capacitor from zero using the decade box and vary the load current until oscillations appear. Record the values of load current and ESR that cause the greatest oscillation. This represents the worst case load conditions for the regulator at low temperature.

Step 4: Maintain the worst case load conditions set in step 3 and vary the input voltage until the oscillations increase. This point represents the worst case input voltage conditions.

Step 5: If the capacitor is adequate, repeat steps 3 and 4 with the next smaller valued capacitor. A smaller capaci-

tor will usually cost less and occupy less board space. If the output oscillates within the range of expected operating conditions, repeat steps 3 and 4 with the next larger standard capacitor value.

Step 6: Test the load transient response by switching in various loads at several frequencies to simulate its real working environment. Vary the ESR to reduce ringing.

Step 7: Remove the unit from the environmental chamber and heat the IC with a heat gun. Vary the load current as instructed in step 5 to test for any oscillations.

Once the minimum capacitor value with the maximum ESR is found, a safety factor should be added to allow for the tolerance of the capacitor and any variations in regulator performance. Most good quality aluminum electrolytic capacitors have a tolerance of $\pm 20\%$ so the minimum value found should be increased by at least 50% to allow for this tolerance plus the variation which will occur at low temperatures. The ESR of the capacitor should be less than 50% of the maximum allowable ESR found in step 3 above.

Calculating Power Dissipation in a Single Output Linear Regulator

The maximum power dissipation for a single output regulator (Figure 2) is:

$$P_{D(\max)} = \{V_{IN(\max)} - V_{OUT(\min)}\}I_{OUT(\max)} + V_{IN(\max)}I_Q \quad (1)$$

where:

$V_{IN(\max)}$ is the maximum input voltage,

$V_{OUT(\min)}$ is the minimum output voltage,

$I_{OUT(\max)}$ is the maximum output current for the application, and

I_Q is the quiescent current the regulator consumes at $I_{OUT(\max)}$.

Once the value of $P_{D(\max)}$ is known, the maximum permissible value of $R_{\theta JA}$ can be calculated:

$$R_{\theta JA} = \frac{150^\circ\text{C} - T_A}{P_D} \quad (2)$$

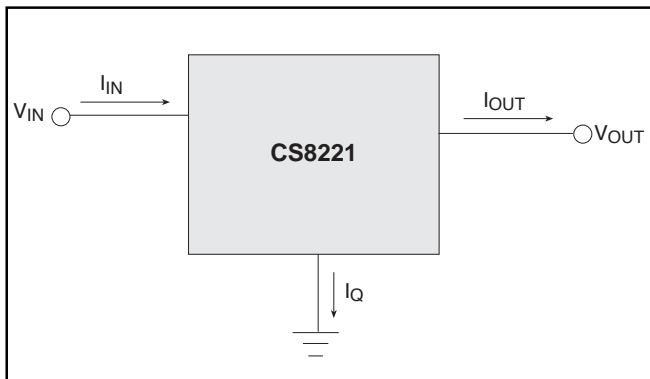

Figure 2. Single output regulator with key performance parameters labeled.

The value of $R_{\theta JA}$ can then be compared with those in the package section of the data sheet. Those packages with $R_{\theta JA}$'s less than the calculated value in equation 2 will keep the die temperature below 150°C .

In some cases, none of the packages will be sufficient to dissipate the heat generated by the IC, and an external heatsink will be required.

Heat Sinks

A heat sink effectively increases the surface area of the package to improve the flow of heat away from the IC and into the surrounding air.

Each material in the heat flow path between the IC and the outside environment will have a thermal resistance. Like series electrical resistances, these resistances are summed to determine the value of $R_{\theta JA}$:

$$R_{\theta JA} = R_{\theta JC} + R_{\theta CS} + R_{\theta SA} \quad (3)$$

where:

$R_{\theta JC}$ = the junction-to-case thermal resistance,

$R_{\theta CS}$ = the case-to-heatsink thermal resistance, and

$R_{\theta SA}$ = the heatsink-to-ambient thermal resistance.

$R_{\theta JC}$ appears in the package section of the data sheet. Like $R_{\theta JA}$, it too is a function of package type. $R_{\theta CS}$ and $R_{\theta SA}$ are functions of the package type, heatsink and the interface between them. These values appear in heat sink data sheets of heat sink manufacturers.

Package Specification

CS8221

PACKAGE DIMENSIONS IN mm (INCHES)

Lead Count	D			
	Metric		English	
	Max	Min	Max	Min
8L SO Narrow <i>(internally fused leads)</i>	5.00	4.80	.197	.189

PACKAGE THERMAL DATA

Thermal Data		8 Lead SO Narrow <i>(internally fused leads)</i>	3 Lead D ² PAK	
R _{θJC}	typ	25	4.2	°C/W
R _{θJA}	typ	110	10-50*	°C/W

*Depending on thermal properties of substrate. R_{θJA} = R_{θJC} + R_{θCA}

Surface Mount Narrow Body (D); 150 mil wide

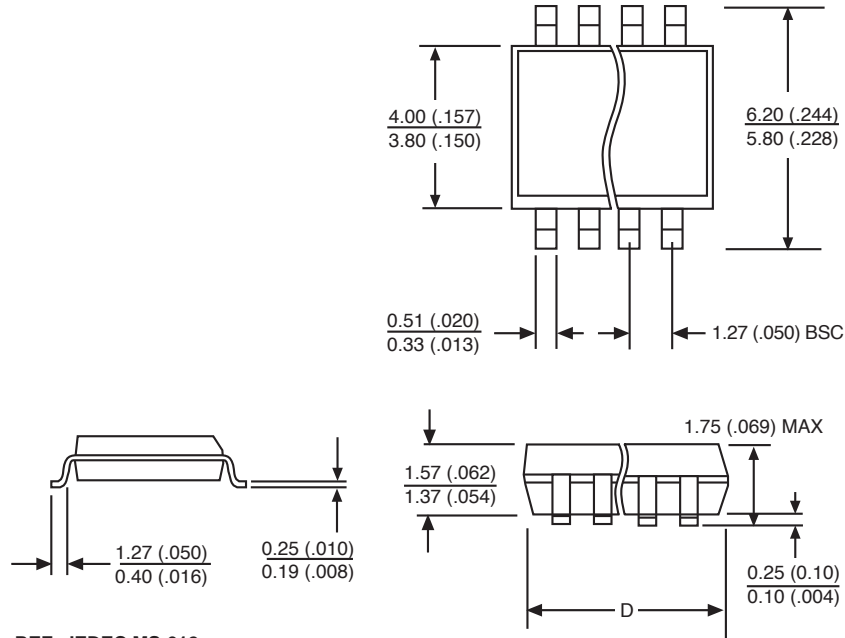

REF: JEDEC MS-012

3 Lead D²PAK (DP)

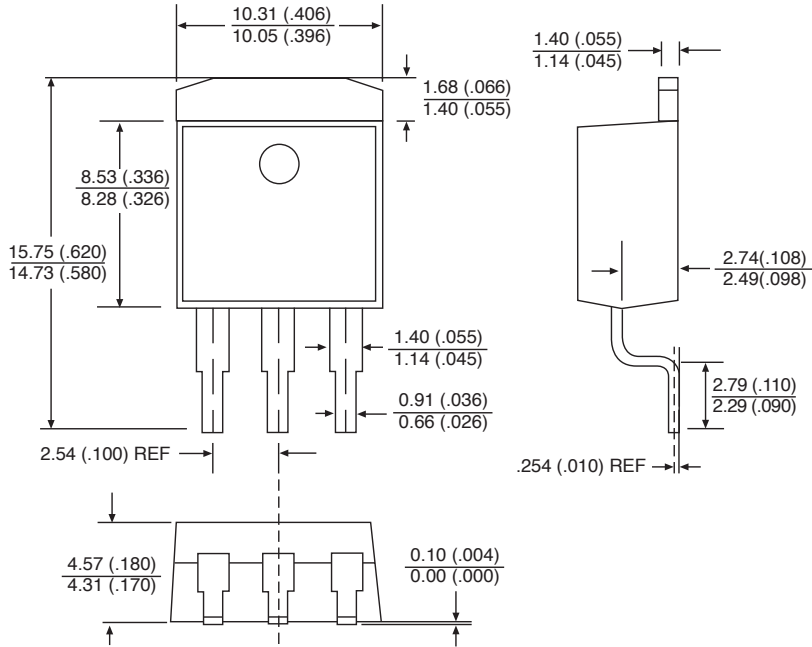

Ordering Information

Part Number	Description
CS8221YDF8	8L SO Narrow (<i>internally fused leads</i>)
CS8221YDFR8	8L SO Narrow (<i>internally fused leads</i>) (<i>tape & reel</i>)
CS8221YDP3	3L D ² PAK
CS8221YDPR3	3L D ² PAK (<i>tape & reel</i>)

Cherry Semiconductor Corporation reserves the right to make changes to the specifications without notice. Please contact Cherry Semiconductor Corporation for the latest available information.