

May 1990

Voltage Comparator

For Commercial and Industrial Applications

Features:

- Single- or dual-supply operation
- Power consumption - 135 mW at ± 15 V
- Strobe capability
- Low input-offset current - 6 nA(typ.)
- Differential input-voltage range - ± 30 V
- Directly interchangeable with National Semiconductor LM311 Series

Applications:

- Multivibrators
- Positive and negative peak detectors
- Crystal oscillators
- Zero-crossing detectors
- Solenoid, relay, and lamp drivers

The CA311 is a monolithic voltage comparator that operates from dual supplies up to ± 15 V, or from single supplies down to 5 V. This single supply capability makes the outputs of these devices compatible with RTL, DTL, TTL, and MOS circuits. In addition they can drive lamps or relays, and switch voltages up to 40 V at currents as high as 50 mA.

The CA311 is available in 8-lead TO-5 style packages with standard leads (T suffix), dual-in-line formed leads ("DIL-CAN", S suffix), 8-lead dual-in-line plastic package ("MINI-DIP", E suffix), and in chip form (H suffix).

The inputs and outputs of the CA311 can be isolated from

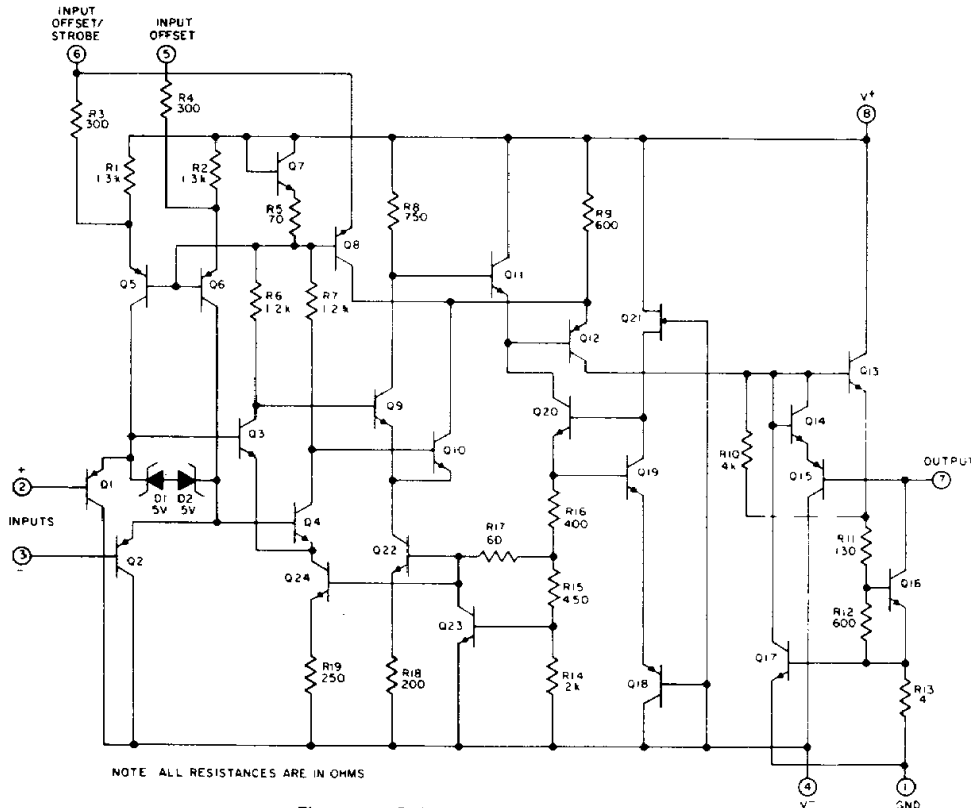

Figure 1 - Schematic diagram of CA311.

*Technical Data on LM Branded types is identical to the corresponding CA Branded types.

CA311, LM311

Maximum Ratings, Absolute Maximum Values at $T_A = 25^\circ\text{C}$:

DC SUPPLY VOLTAGE (between V^+ and V^- terminals)	36 V
DC INPUT VOLTAGE*	± 15 V
DIFFERENTIAL INPUT VOLTAGE	± 30 V
OUTPUT TO NEGATIVE SUPPLY VOLTAGE (V_7-4)	40 V
GROUND TO NEGATIVE SUPPLY VOLTAGE (V_1-4)	30 V
OUTPUT SHORT-CIRCUIT DURATION	10 s
DEVICE DISSIPATION:	
UP TO $T_A = 25^\circ\text{C}$	500 mW
Above $T_A = 25^\circ\text{C}$	derate linearly at 6.67 mW/ $^\circ\text{C}$
AMBIENT TEMPERATURE RANGE:	
Operating	0 to $+70^\circ\text{C}$ †
Storage	-65 to $+150^\circ\text{C}$
LEAD TEMPERATURE (DURING SOLDERING):	
At distance $1/16 \pm 1/32$ inch (1.59 ± 0.79 mm) from case for 10 seconds max.	$+265^\circ\text{C}$

*This rating applies for ± 15 V supplies. The positive input-voltage limit is 30 V above the negative supply. The negative input-voltage limit is equal to the negative supply voltage or 30 V below the positive supply. The negative input-voltage limit is equal to the negative supply voltage or 30 V below the positive supply, whichever is less.

†Types CA311 E, S, and T can be operated over the temperature range of -55 to $+125^\circ\text{C}$, although the published limits for certain electrical specifications apply only over the temperature range of 0 to 70°C .

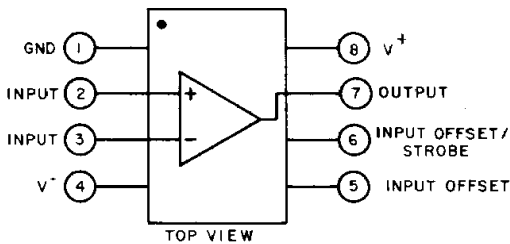

FUNCTIONAL DIAGRAM FOR PLASTIC PACKAGE.

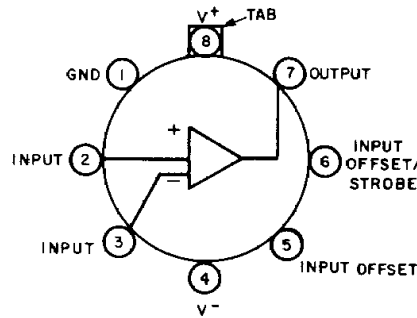

FUNCTIONAL DIAGRAM FOR TO-5 STYLE PACKAGE.

4
COMPARATORS

TYPICAL CHARACTERISTICS

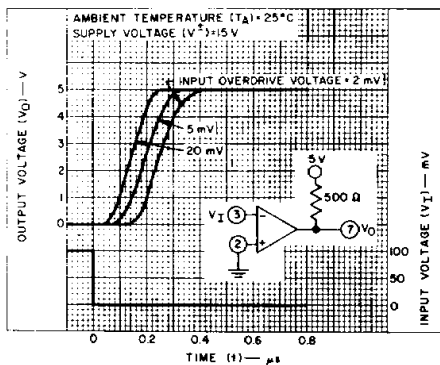

Fig. 2 — Response time for various input overdrive voltages — positive input.

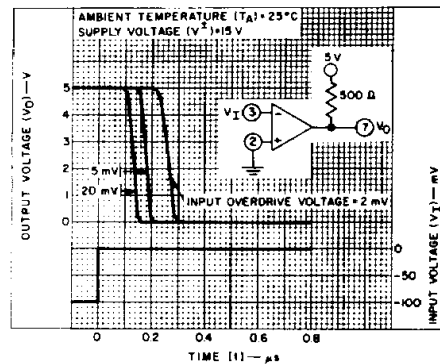

Fig. 3 — Response time for various input overdrive voltages — negative input.

CA311, LM311

ELECTRICAL CHARACTERISTICS

CHARACTERISTICS		TEST CONDITIONS		LIMITS			UNITS
		SUPPLY VOLTAGE (V_{\pm}) = 15V UNLESS OTHERWISE SPECIFIED		CA311			
				MIN.	TYP.	MAX.	
Input Offset Voltage	V_{IO}	$R_s \leq 5 \text{ k}\Omega$, Note 2	$T_A = 25^\circ \text{C}$	—	2	7.5	mV
			Note 1	—	—	10	
Saturation Voltage		$V_i \leq -10 \text{ mV}$, $I_o = 50 \text{ mA}$	$T_A = 25^\circ \text{C}$	—	0.75	1.5	V
			Note 1	—	0.23	0.4	
Input Voltage Range	V_{IPP}		Note 1	—	± 14	—	V
Input Offset Current	I_{IO}	Note 2	$T_A = 25^\circ \text{C}$	—	6	50	nA
			Note 1	—	—	70	
Input Bias Current	I_{IB}	Note 2	$T_A = 25^\circ \text{C}$	—	100	250	nA
			Note 1	—	—	300	
Positive Supply Current	I^+		$T_A = 25^\circ \text{C}$	—	5.1	7.5	mA
Negative Supply Current	I^-		$T_A = 25^\circ \text{C}$	—	4.1	5	mA
Output Leakage Current		$V_i \geq 10 \text{ mV}$, $V_o = 35 \text{ V}$	$T_A = 25^\circ \text{C}$	—	—	50	nA
Strobe on Current			$T_A = 25^\circ \text{C}$	—	3	—	mA
Voltage Gain, A			$T_A = 25^\circ \text{C}$	40	200	—	V/mV
Response Time		100 mV Input Step with 5 mV Overdrive Voltage	$T_A = 25^\circ \text{C}$	—	200	—	ns
Input Voltage Range			$T_A = 25^\circ \text{C}$	-14.5	13.8- -14.7	13	V

Note 1: Ambient temperature (T_A) over applicable operating temperature of 0 to $+70^\circ \text{C}$.

Note 2: The input offset characteristics given are the values required to drive the output to within 1 V of either supply with a 1 mA load. These characteristics define an error band which takes into account the worst-case effects of voltage gain and input impedance. The input offset voltage, input offset current, and input bias current specifications apply for any supply voltage from a 5 V single supply up to a $\pm 15 \text{ V}$ dual supply.

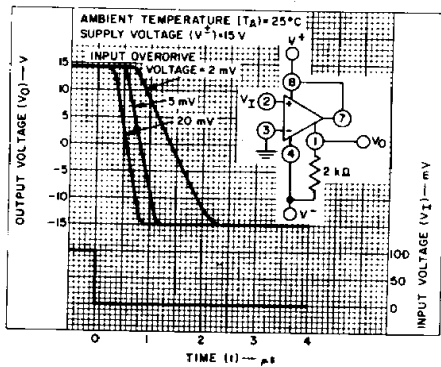

Fig. 4 - Response time for various input overdrive voltages - positive input.

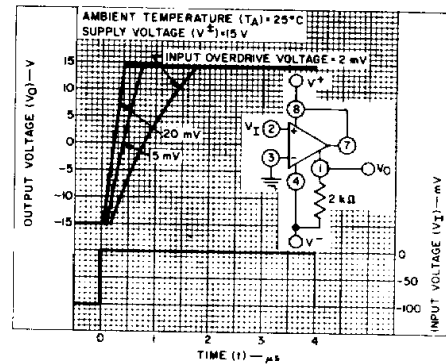

Fig. 5 - Response time for various input overdrive voltages - negative input.

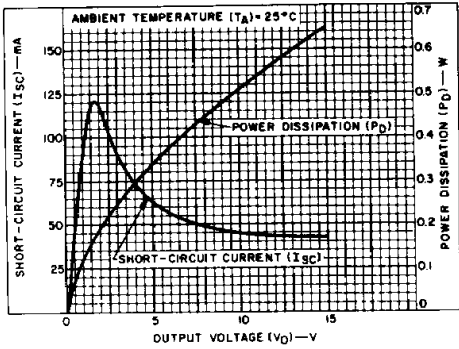

Fig. 6 - Output limiting characteristics.

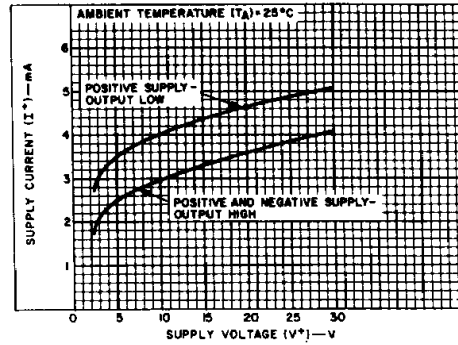

Fig. 7 - Supply current vs. supply voltage.

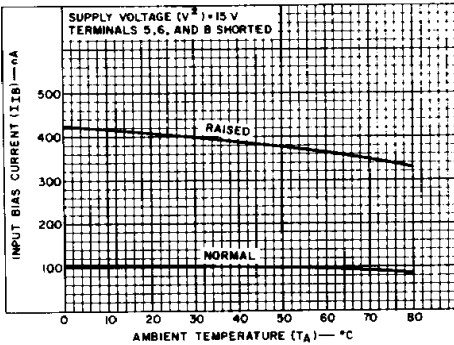

Fig. 8 - Input bias current vs. ambient temperature.

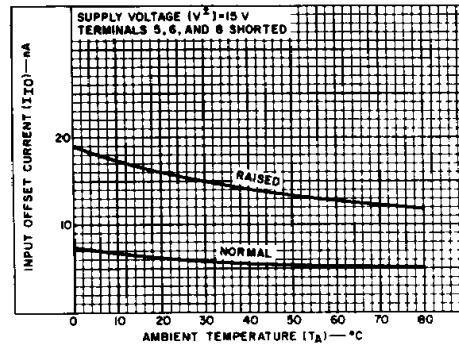

Fig. 9 - Input offset current vs. ambient temperature.

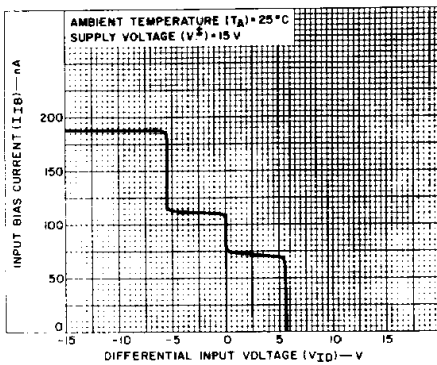

Fig. 10 - Input characteristics.

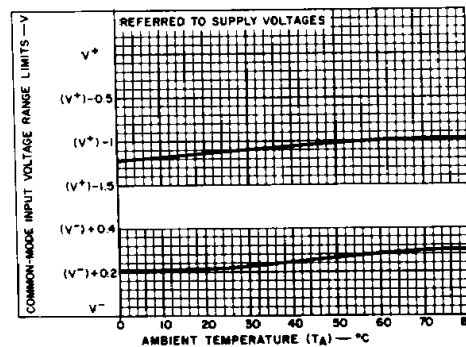

Fig. 11 - Common-mode voltage range limits vs. ambient temperature.

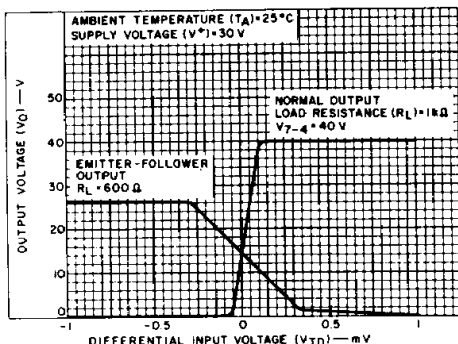

Fig. 12 - Transfer function.

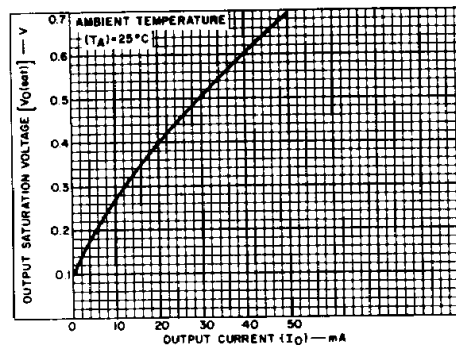

Fig. 13 - Output saturation voltage vs. output current.

CA311, LM311

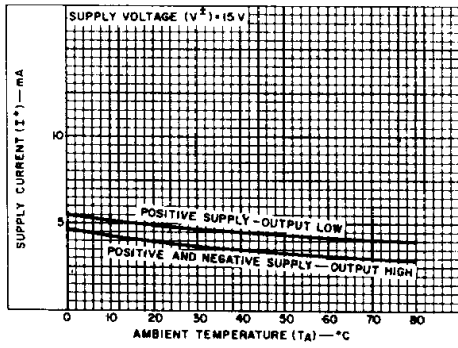

Fig. 14 - Supply current vs. ambient temperature.

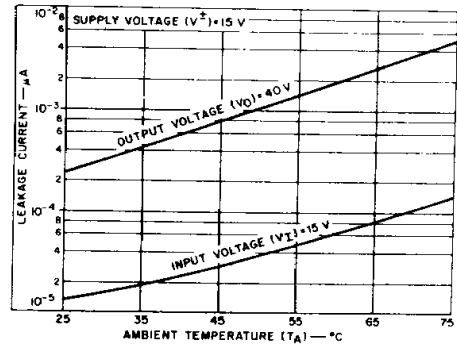

Fig. 15 - Input and output leakage current vs. ambient temperature.

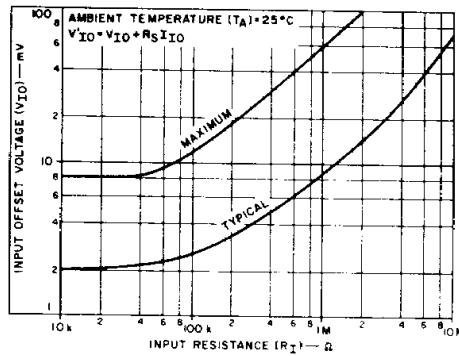

Fig. 16 - Offset error.

TYPICAL APPLICATIONS

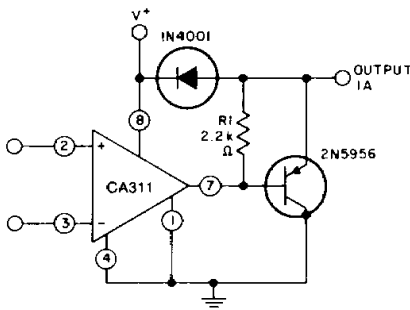

Fig. 17 - Comparator and solenoid driver.

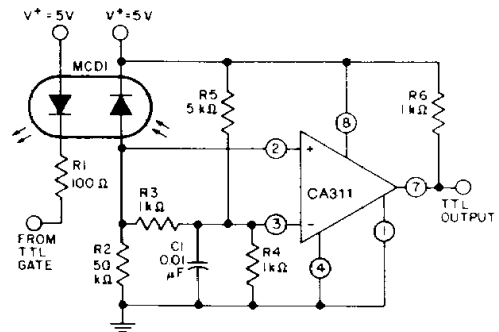
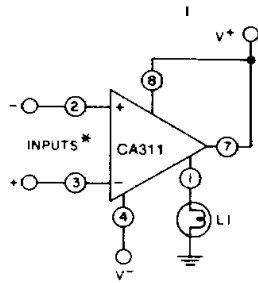

Fig. 18 - Digital transmission isolator.



*INPUT POLARITY IS REVERSED WHEN USING PIN 1 AS OUTPUT

Fig. 19 - Driving a ground-referred load.

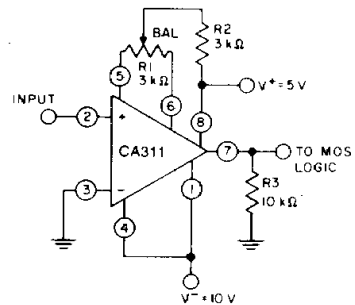

Fig. 20 - Zero-crossing detector driving MOS logic.

TYPICAL APPLICATIONS (cont'd)

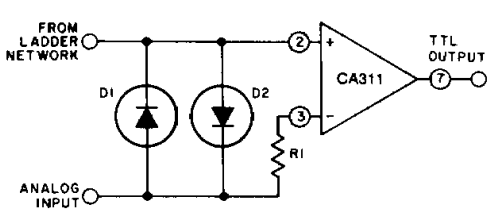

Fig. 21 - Using clamp diodes to improve response.

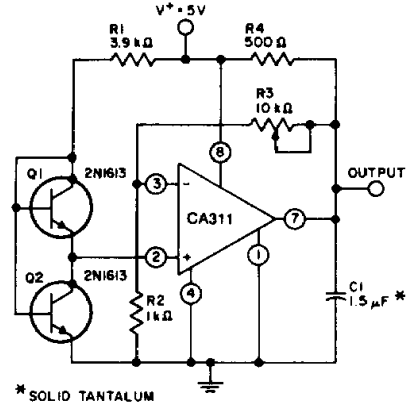

Fig. 22 - Low-voltage adjustable-reference supply.

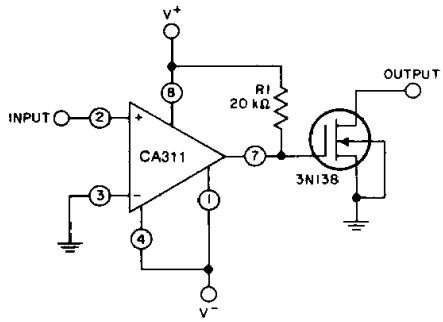
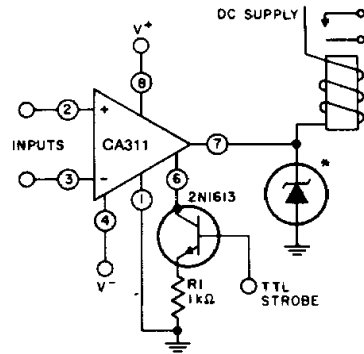

Fig. 23 - Zero-crossing detector driving and MOS switch.



* ABSORBS INDUCTIVE KICKBACK OF RELAY AND PROTECTS IC FROM SEVERE VOLTAGE TRANSIENTS ON DC SUPPLY LINE

Fig. 24 - Relay driver with strobe.

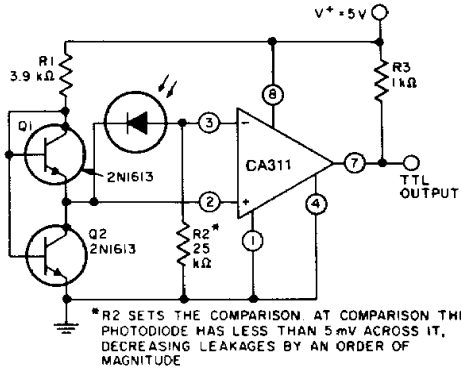

Fig. 25 - Precision photodiode comparator.

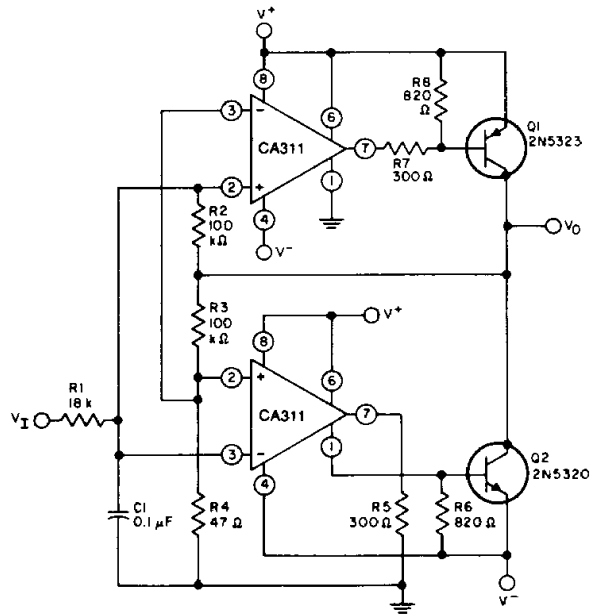

Fig. 27 - Switching power amplifier.

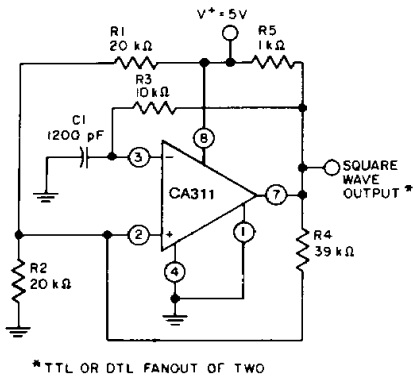

Fig. 26 - 100-kHz free-running multivibrator.

TYPICAL APPLICATIONS (cont'd)

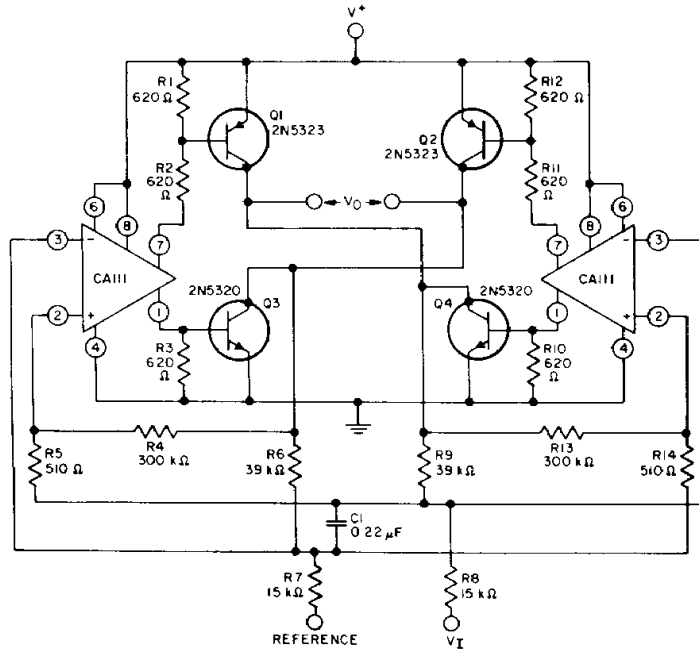
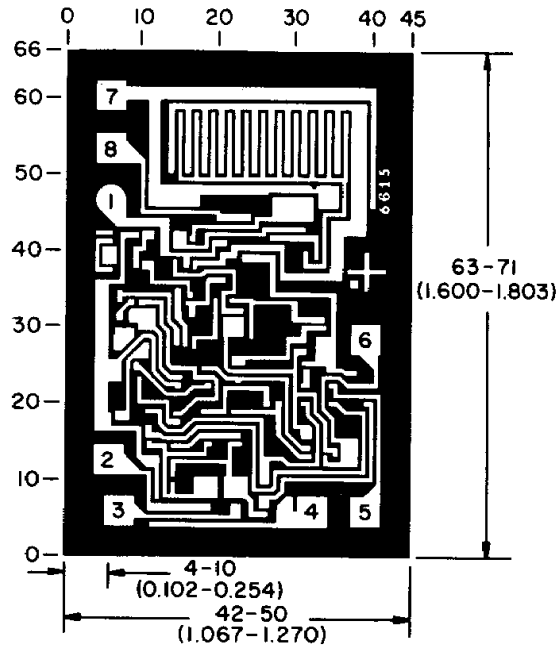

Fig. 33 - Switching power amplifier.



Dimensions and pad layout for CA311H.

Dimensions in parentheses are in millimeters and are derived from the basic inch dimensions as indicated. Grid graduations are in mils (10^{-3} inch).