

NPN Silicon RF Transistor

- For highest gain low noise amplifier at 1.8 GHz
- Outstanding $G_{ms} = 20$ dB
Noise Figure $F = 0.9$ dB
- Gold metallization for high reliability
- SIEGET 45 - Line

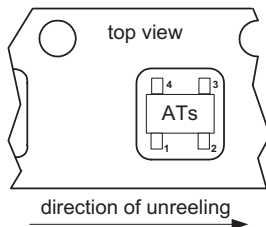
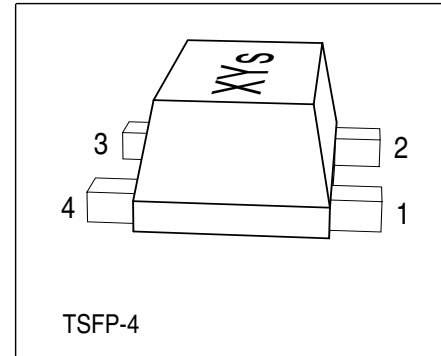

ESD: Electrostatic discharge sensitive device, observe handling precaution!

Type	Marking	Pin Configuration						Package
BFP540F	ATs*	1=B	2=E	3=C	4=E	-	-	TSFP-4

* Pin configuration fixed relative to marking (see package picture)

Maximum Ratings

Parameter	Symbol	Value	Unit
Collector-emitter voltage	V_{CEO}	4.5	V
Collector-emitter voltage	V_{CES}	14	
Collector-base voltage	V_{CBO}	14	
Emitter-base voltage	V_{EBO}	1	
Collector current	I_C	80	mA
Base current	I_B	8	
Total power dissipation ¹⁾ $T_S \leq 80^\circ\text{C}$	P_{tot}	250	mW
Junction temperature	T_j	150	$^\circ\text{C}$
Ambient temperature	T_A	-65 ... 150	
Storage temperature	T_{stg}	-65 ... 150	

Thermal Resistance

Parameter	Symbol	Value	Unit
Junction - soldering point ²⁾	R_{thJS}	≤ 280	K/W

¹⁾ T_S is measured on the collector lead at the soldering point to the pcb

²⁾ For calculation of R_{thJA} please refer to Application Note Thermal Resistance

Electrical Characteristics at $T_A = 25^\circ\text{C}$, unless otherwise specified

Parameter	Symbol	Values			Unit
		min.	typ.	max.	
DC Characteristics					
Collector-emitter breakdown voltage $I_C = 1\text{ mA}, I_B = 0$	$V_{(BR)CEO}$	4.5	5	-	V
Collector-emitter cutoff current $V_{CE} = 14\text{ V}, V_{BE} = 0$	I_{CES}	-	-	10	μA
Collector-base cutoff current $V_{CB} = 5\text{ V}, I_E = 0$	I_{CBO}	-	-	100	nA
Emitter-base cutoff current $V_{EB} = 0.5\text{ V}, I_C = 0$	I_{EBO}	-	-	10	μA
DC current gain $I_C = 20\text{ mA}, V_{CE} = 3.5\text{ V}$	h_{FE}	50	110	200	-

Electrical Characteristics at $T_A = 25^\circ\text{C}$, unless otherwise specified

Parameter	Symbol	Values			Unit
		min.	typ.	max.	
AC Characteristics (verified by random sampling)					
Transition frequency $I_C = 50\text{ mA}$, $V_{CE} = 4\text{ V}$, $f = 1\text{ GHz}$	f_T	21	30	-	GHz
Collector-base capacitance $V_{CB} = 2\text{ V}$, $f = 1\text{ MHz}$	C_{cb}	-	0.14	0.24	pF
Collector emitter capacitance $V_{CE} = 2\text{ V}$, $f = 1\text{ MHz}$	C_{ce}	-	0.3	-	
Emitter-base capacitance $V_{EB} = 0.5\text{ V}$, $f = 1\text{ MHz}$	C_{eb}	-	0.6	-	
Noise figure $I_C = 5\text{ mA}$, $V_{CE} = 2\text{ V}$, $f = 1.8\text{ GHz}$, $Z_S = Z_{Sopt}$ $I_C = 5\text{ mA}$, $V_{CE} = 2\text{ V}$, $f = 3\text{ GHz}$, $Z_S = Z_{Sopt}$	F	-	0.9	1.4	dB
Power gain, maximum available ¹⁾ $I_C = 20\text{ mA}$, $V_{CE} = 2\text{ V}$, $Z_S = Z_{Sopt}$, $Z_L = Z_{Lopt}$, $f = 1.8\text{ GHz}$ $I_C = 20\text{ mA}$, $V_{CE} = 2\text{ V}$, $Z_S = Z_{Sopt}$, $Z_L = Z_{Lopt}$, $f = 3\text{ GHz}$	G_{ma}	-	20	-	
Transducer gain $I_C = 20\text{ mA}$, $V_{CE} = 2\text{ V}$, $Z_S = Z_L = 50\ \Omega$, $f = 1.8\text{ GHz}$ $I_C = 20\text{ mA}$, $V_{CE} = 2\text{ V}$, $Z_S = Z_L = 50\ \Omega$, $f = 3\text{ GHz}$	$ S_{21e} ^2$	15.5	18	-	dB
Third order intercept point at output ²⁾ $V_{CE} = 2\text{ V}$, $I_C = 20\text{ mA}$, $f = 1.8\text{ GHz}$, $Z_S = Z_L = 50\ \Omega$	IP_3	-	24.5	-	dBm
1dB Compression point at output $I_C = 20\text{ mA}$, $V_{CE} = 2\text{ V}$, $Z_S = Z_L = 50\ \Omega$, $f = 1.8\text{ GHz}$	P_{-1dB}	-	11	-	

¹⁾ $G_{ma} = |S_{21e} / S_{12e}| (k - (k^2 - 1)^{1/2})$, $G_{ms} = |S_{21e} / S_{12e}|$
²⁾ IP_3 value depends on termination of all intermodulation frequency components.
Termination used for this measurement is $50\ \Omega$ from 0.1 MHz to 6 GHz

SPICE Parameter (Gummel-Poon Model, Berkley-SPICE 2G.6 Syntax):
Transistor Chip Data:

IS =	82.84	aA	BF =	107.5	-	NF =	1	-
VAF =	28.383	V	IKF =	0.48731	A	ISE =	11.15	fA
NE =	3.19	-	BR =	5.5	-	NR =	1	-
VAR =	19.705	V	IKR =	0.02	A	ISC =	19.237	aA
NC =	1.172	-	RB =	5.4	Ω	IRB =	0.72983	mA
RBM =	1.3	Ω	RE =	0.31111	-	RC =	4	Ω
CJE =	1.8063	fF	VJE =	0.8051	V	MJE =	0.46576	-
TF =	6.76	ps	XTF =	0.4219	-	VTF =	0.23794	V
ITF =	1	mA	PTF =	0	deg	CJC =	234	fF
VJC =	0.81969	V	MJC =	0.30232	-	XCJC =	0.3	-
TR =	2.324	ns	CJS =	0	fF	VJS =	0.75	V
MJS =	0	-	XTB =	0	-	EG =	1.11	eV
XTI =	3	-	FC =	0.73234	-	TNOM	300	K

All parameters are ready to use, no scaling is necessary.

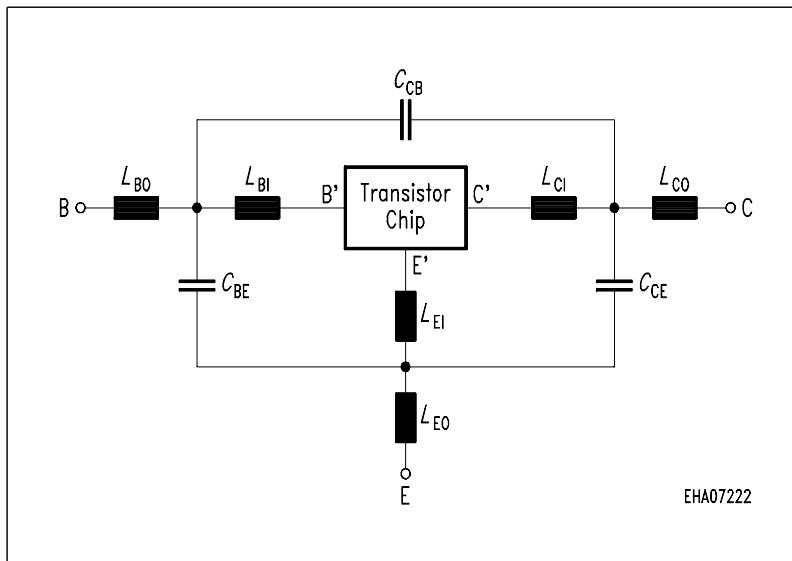
Package Equivalent Circuit:

The TSFP-4 package has two emitter leads. To avoid high complexity of the package equivalent circuit, both lead are combined in on electrical connection. R_{LxI} are series resistors for the inductance L_{xI} and K_{xa-yb} are the coupling coefficients between the inductance L_{xa} and L_{yb} . The referencepins for the couple ports are B, E, C, B', E', C'.

For examples and ready to use parameters please contact your local Infineon Technologies distributor or sales office to obtain a Infineon Technologies CD-ROM or see Internet: <http://www.infineon.com/silicondiscretes>

L_{BI} =	0.42	nH
L_{BO} =	0.22	nH
L_{EI} =	0.26	nH
L_{EO} =	0.28	nH
L_{CI} =	0.35	pH
L_{CO} =	0.22	nH
C_{BE} =	34	fF
C_{BC} =	2	fF
C_{CE} =	33	fF
K_{BO-EO} =	0.1	-
K_{BO-CO} =	0.01	-
K_{EO-CO} =	0.11	-
K_{CI-EI} =	-0.05	-
K_{BI-CI} =	-0.08	-
K_{EI-CI} =	0.2	-
R_{LBI} =	0.15	Ω
R_{LEI} =	0.11	Ω
R_{LCI} =	0.13	Ω

Valid up to 6GHz

Total power dissipation $P_{tot} = f(T_S)$

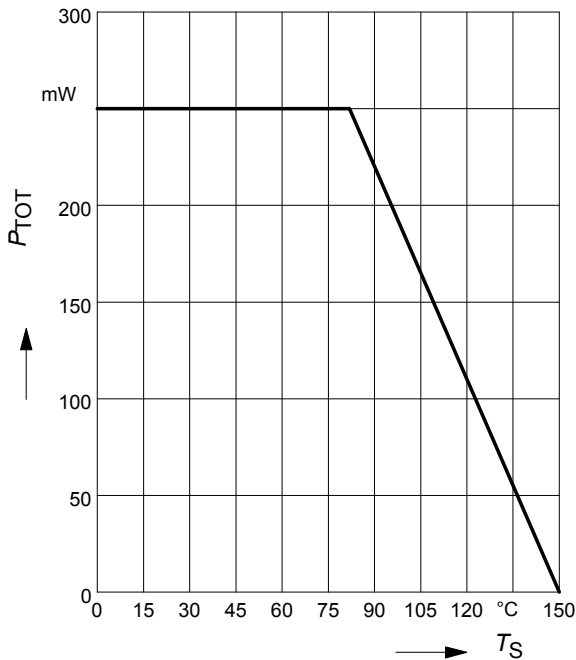

Permissible Pulse Load $R_{thJS} = f(t_p)$

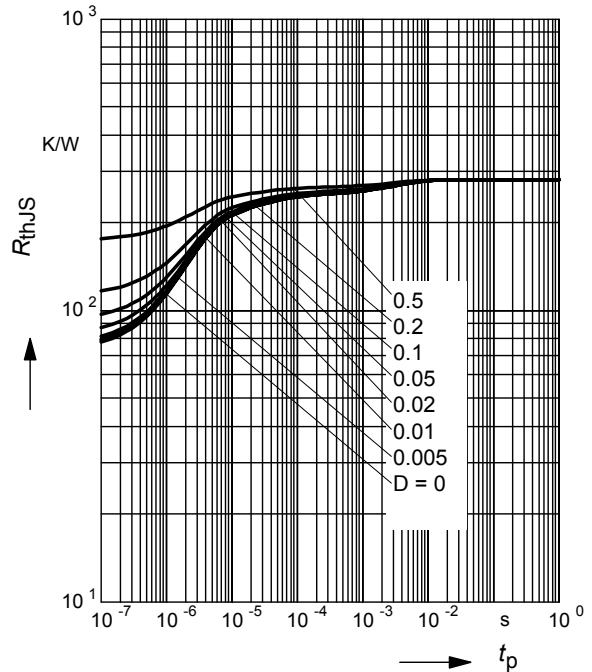

Permissible Pulse Load

$P_{totmax}/P_{totDC} = f(t_p)$

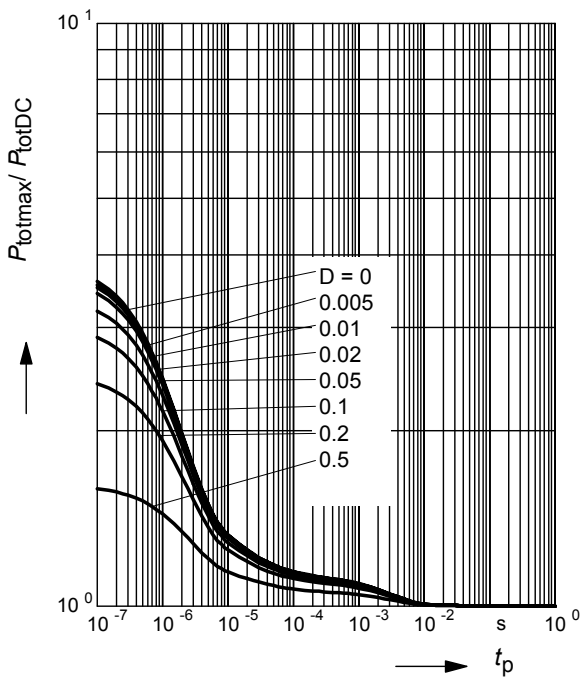

Collector-base capacitance $C_{cb} = f(V_{CB})$

$f = 1\text{MHz}$

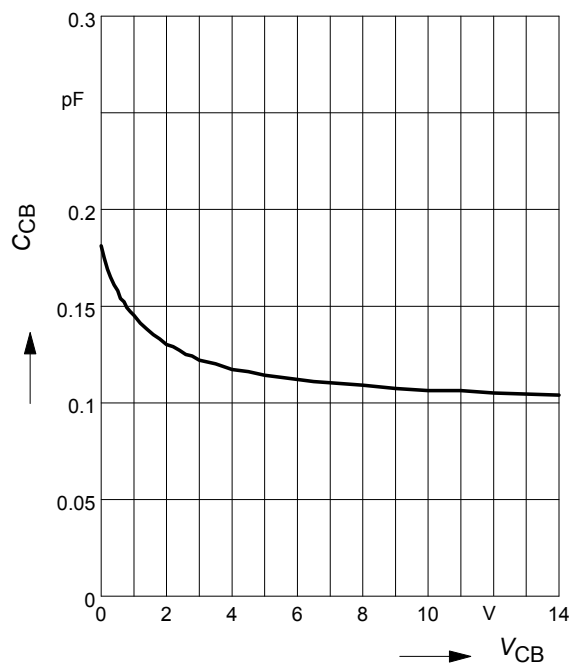

Transition frequency $f_T = f(I_C)$

$f = 1\text{GHz}$

$V_{CE} = \text{Parameter in V}$

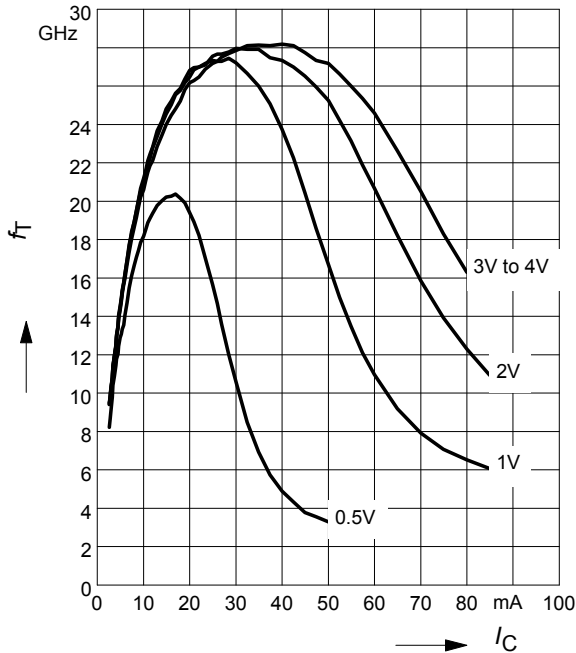

Power gain $G_{ma}, G_{ms} = f(I_C)$

$V_{CE} = 2\text{V}$

$f = \text{Parameter in GHz}$

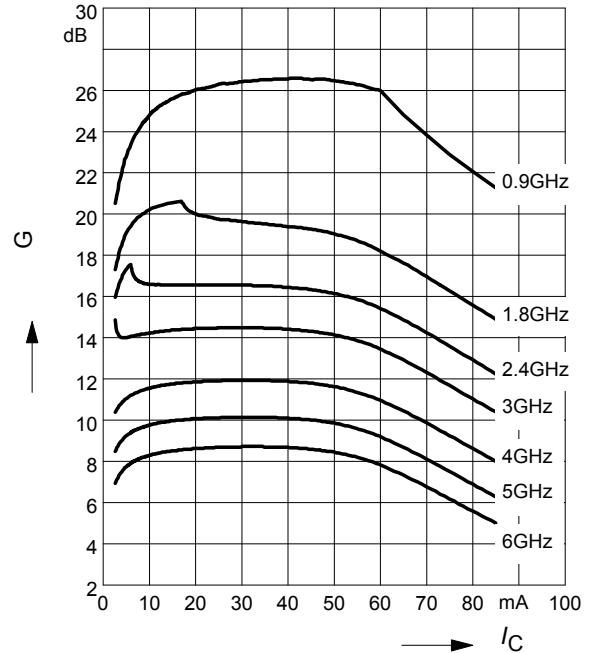

Power Gain $G_{ma}, G_{ms} = f(f)$,

$|S_{21}|^2 = f(f)$

$V_{CE} = 2\text{V}, I_C = 20\text{mA}$

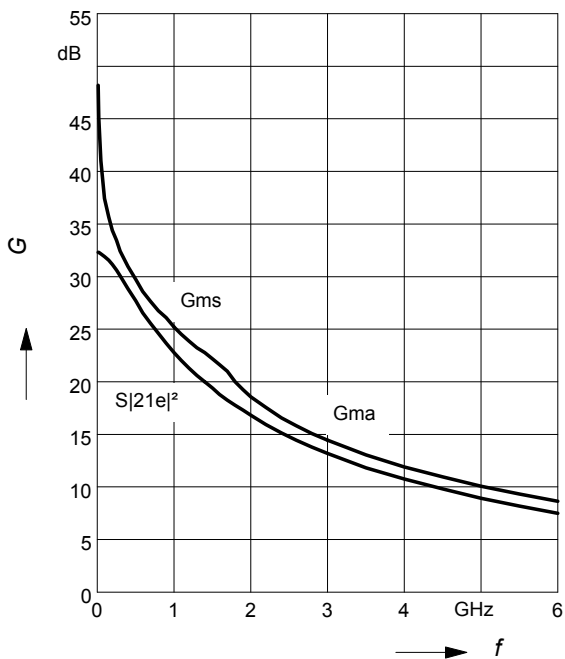

Power gain $G_{ma}, G_{ms} = f(V_{CE})$

$I_C = 20\text{mA}$

$f = \text{Parameter in GHz}$

