



MES FIELD EFFECT TRANSISTOR

NE41137

PRELIMINARY DATA SHEET

N-Channel GaAs Dual-Gate MES FET

FEATURES

- LOW C_{rss} : 0.03pF TYP.
- HIGH G_{ps} : 20dB TYP. at 900 MHz
- LOW NF: 1.3dB TYP. at 900MHz
- LOW COST

ABSOLUTE MAXIMUM RATINGS ($T_a=25^\circ C$)

SYMBOLS	PARAMETERS	UNITS	RATINGS
V _{DSX}	Drain to Source Voltage	V	10
V _{G1S}	Gate1 to Source Voltage	V	-4.5
V _{G2S}	Gate2 to Source Voltage	V	-4.5
I _D	Drain Current	mA	80
P _T	Total Power Dissipation	mW	200
T _{ch}	Channel Temperature	°C	125
T _{stg}	Storage Temperature	°C	-55 to +125

PHYSICAL DIMENSIONS (Units in mm)

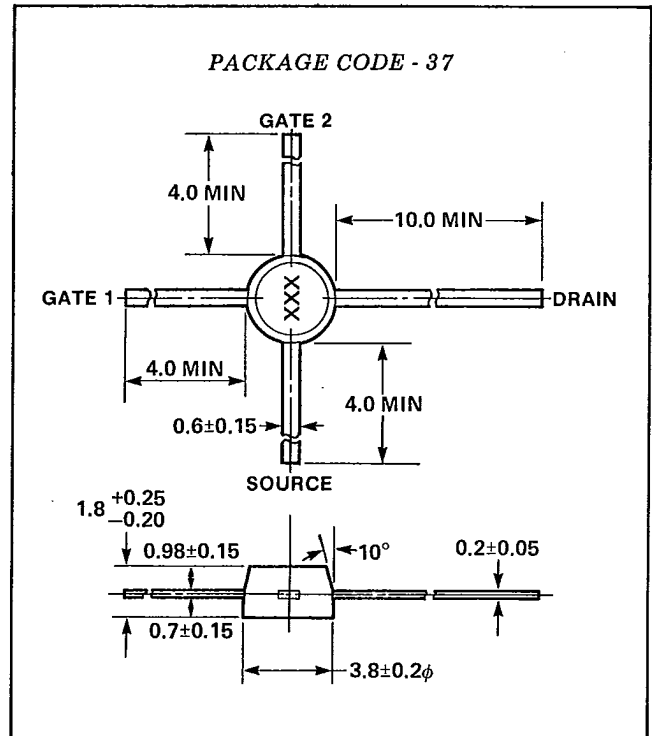

ELECTRICAL CHARACTERISTICS ($T_a=25^\circ C$)

NE PART NUMBER EIAJ* REGISTERED NUMBER PACKAGE CODE			NE41137 3SK124 37		
SYMBOLS	PARAMETERS AND CONDITIONS	UNITS	MIN	TYP	MAX
BV _{DSX}	Drain to Source Breakdown Voltage at V _{G1S} =3V, V _{G2S} =0, I _D =10μA	V	10		
I _{DSS}	Drain Current at V _{DS} =5V, V _{G2S} =0, V _{G1S} =0	mA	20	40	80
V _{G1S(off)}	Gate1 to Source Cutoff Voltage at V _{DS} =5V, V _{G2S} =0, I _D =100μA	V			-3
V _{G2S(off)}	Gate2 to Source Cutoff Voltage at V _{DS} =5V, V _{G1S} =0, I _D =100μA	V			-3
I _{G1SS}	Gate1 Reverse Current at V _{DS} =0, V _{G1S} =±4V, V _{G2S} =0	μA			20
I _{G2SS}	Gate2 Reverse Current at V _{DS} =0, V _{G2S} =±4V, V _{G1S} =0	μA			20
Y _{fs}	Forward Transfer Admittance at V _{DS} =5V, V _{G2S} =0, I _D =10mA, f = 1.0kHz	mS	20	30	
C _{iss}	Input Capacitance at V _{DS} =5V, V _{G2S} =0, I _D =10mA, f = 1MHz	pF	1.5	2.0	2.5
C _{rss}	Reverse Transfer Capacitance at V _{DS} =5V, V _{G2S} =0, I _D =10mA, f = 1MHz	pF		0.03	0.04
G _{ps}	Power Gain at V _{DS} =5V, V _{G2S} =0, I _D =10mA, f = 900MHz	dB	16	20	
NF	Noise Figure at V _{DS} =5V, V _{G2S} =0, I _D =10mA, f = 900MHz	dB	1.3	2.5	

*Electronic Industries Association - Japan.

NE41137 COMMON EMITTER SCATTERING PARAMETERS

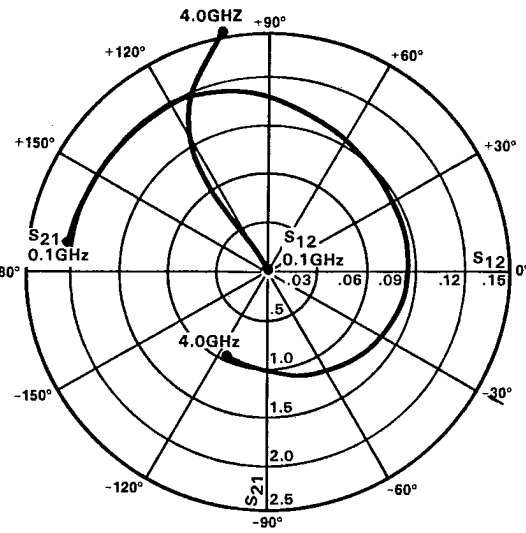
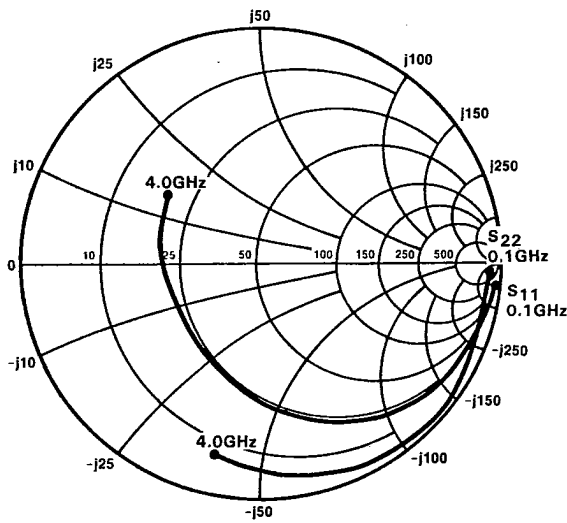

Coordinates in Ohms
Frequency in GHz
(V_{DS}=5V, I_{DS}=10mA)

S-MAGN AND ANGLES:

V_{DS}=5V, I_{DS}=5mA, V_{G2S}=0

FREQUENCY (MHz)	S11		S21		S12		S22	
100	1.00	-6	1.79	170	.00	102	.99	-2
500	.91	-31	1.74	136	.00	78	.98	-8
1000	.78	-58	1.64	100	.00	109	.96	-18
1500	.61	-84	1.43	63	.00	92	1.00	-28
2000	.48	-107	1.25	32	.01	119	.99	-39
2500	.36	-132	1.12	-1	.04	127	.97	-49
3000	.31	-157	1.01	-33	.06	126	.97	-62
3500	.30	-180	.89	-72	.09	120	.95	-78
4000	.35	160	.75	-113	.13	109	.82	-97

V_{DS}=5V, I_{DS}=10mA, V_{G2S}=0

100	1.00	-6	2.07	170	.00	96	.98	-1
500	.91	-34	2.01	136	.00	79	.97	-8
1000	.77	-64	1.92	98	.00	108	.95	-18
1500	.60	-91	1.70	61	.00	97	.99	-28
2000	.48	-116	1.52	29	.01	120	.98	-38
2500	.39	-143	1.43	-5	.04	124	.96	-52
3000	.38	-169	1.33	-39	.07	123	.95	-66
3500	.43	167	1.17	-79	.11	113	.91	-83
4000	.50	143	.96	-118	.15	101	.81	-101

V_{DS}=5V, I_{DS}=15mA, V_{G2S}=0

100	1.00	-7	1.58	170	.00	87	.96	-1
500	.91	-37	1.55	133	.00	76	.96	-7
1000	.77	-70	1.53	93	.00	104	.94	-17
1500	.62	-100	1.42	54	.00	98	.98	-27
2000	.52	-127	1.34	20	.01	117	.97	-38
2500	.46	-156	1.31	-15	.05	121	.94	-50
3000	.49	177	1.26	-50	.07	116	.93	-63
3500	.54	151	1.10	-90	.11	105	.90	-78
4000	.60	129	.91	-126	.15	91	.78	-94



EXCLUSIVE SALES AGENT FOR **NEC Corporation** MICROWAVE SEMICONDUCTORS PRODUCTS — U.S. & CANADA
CALIFORNIA EASTERN LABORATORIES, INC. • Headquarters • 3005 Democracy Way • Santa Clara, CA 95050 • (408) 988-3500 • Telex 34-6393 or 171197